

## User Manual



**Easy Rider 3**



**Easy Rider Compact**



**Easy Rider Small**

Van Raam  
Guldenweg 23  
7051 HT Varsseveld, The Netherlands

☎ +31 (0)315 – 25 73 70

✉ [info@vanraam.com](mailto:info@vanraam.com)

🌐 [www.vanraam.com](http://www.vanraam.com)

Version 24.04



# Table of contents

Manufacturer contact details .....	3
Conformity Europe (CE) .....	3
Conformity UK (UKCA) .....	3
Introduction.....	4
Delivery.....	4
Indication.....	5
Intended usage .....	5
Safety measures.....	6
Adjustment of the tricycle .....	10
Before use .....	18
Silent electro system .....	23
Silent Electrical System options .....	35
Van Raam e-bike app.....	37
Options .....	38
Technical specifications .....	49
Cleaning and maintenance by owner.....	50
Repair and maintenance by dealer .....	51
Return point for removal .....	57
Handover / sale to a new owner .....	57
Warranty .....	58
Frame number.....	59
Maintenance recommendation .....	60
Service plan.....	62
Delivery and service form.....	67

## Manufacturer contact details

Van Raam  
Guldenweg 23  
7051 HT Varsseveld, The Netherlands

☎ +31 (0)315 – 25 73 70

✉ [info@vanraam.com](mailto:info@vanraam.com)

🌐 [www.vanraam.com](http://www.vanraam.com)

## Conformity Europe (CE)

Van Raam Reha Bikes B.V., as manufacturer, declares that the Easy Rider, Easy Rider Compact and Easy Rider Small, as described in this user manual, is manufactured in accordance with Regulation (EU) 2017/745, risk class 1. The Easy Rider, Easy Rider Compact and Easy Rider Small supplied with the Silent electrical system also complies with Directive 2006/42/EC including the applicable parts of EMC Directive 2014/30/EU and the NEN-EN 15194:2017 Bicycles - Electric supporting bicycles - EPAC Bicycles - part 4.2 Electrical requirements. The signed declaration of conformity can be found on the Van Raam website.

## Conformity UK (UKCA)

Van Raam Reha Bikes B.V. as manufacturer declares that the Easy Rider, Easy Rider Compact and Easy Rider Small, as described in this user manual, is manufactured in accordance with the "Essential Requirements of Medical Devices Regulation 2002" (UK MDR 2002 Class 1 Medical Devices). Easy Rider, Easy Rider Compact and Easy Rider Small supplied with the Silent electrical system also complies with the "Machinery (Safety) Directive SI 2008/1597" including the applicable parts of "Electro Magnetic Compatibility Regulations SI 2016/1091" and the NEN-EN 15194:2017 Bicycles - Electric support bicycles - EPAC Bicycles - part 4.2 Electrical requirements. The Easy Rider, Easy Rider Compact and Easy Rider Small is provided with UKCA label according to "EU Exit Regulations 2020/1478". The signed declaration of conformity can be found on the Van Raam website.

## Introduction

This user manual provides important and necessary information about the use of Easy Rider, Easy Rider Compact and Easy Rider Small. In this document, when we mention the Easy Rider, this refers to the Easy Rider 3, both the Medium and the Large variant, unless otherwise stated.



**READ CAREFULLY**

We request that you read this manual thoroughly before using the bicycle. Always follow the instructions as provided in this user manual and keep the manual carefully. The most current version of the user manual can be found on the product page of the bicycle on the website [www.vanraam.com](http://www.vanraam.com).

For children and people with limited mental perception, all safety and handling aspects of this manual must be made understandable by a responsible supervising person.

## Delivery

Delivery must include the following:

- Bicycle with any packaging
- User manual(s)
- Possible Smart battery including card with 5-digit code (depending on options)
- Possible chargers (depending on options)
- Spare keys

Check the delivery immediately upon receipt. In case of damage or an incomplete delivery, we request that you contact your dealer immediately. On delivery, complete the "delivery and service form" on the back of this user manual with your dealer.

## Indication

Children or adults who cannot use bicycles or vehicles due to their disabilities may be able to ride these tricycles. The tricycles can be used by children or adults with a neuromuscular disease (such as congenital brain injury, non-congenital brain injury or muscular dystrophy). This also applies to problems with, for example, coordination, balance disorders and limited natural movement possibilities. If necessary, supervision may be desirable.

## Intended usage

The tricycles are designed for normal use on a flat, solid surface. The usual caution for bicycles should always be observed. The safety instructions as described in this manual must also be strictly followed. Also, the local rules for participation in traffic must always be observed.

The bicycle is intended for one person, this user must be independently mobile and must not have any heavy visual or other restrictions that make it impossible to participate in traffic in a responsible manner. The maximum user weight and luggage weight (can be found under the chapter '**Technical specifications**') may not be exceeded.

Any other use, including damage or injury resulting from this, is not the responsibility of the manufacturer.

## Safety measures

- Take immediate action if any part is loose while using the bicycle, if slack is detected or if you hear a strange noise. If you cannot solve the problem yourself, please contact your Van Raam dealer. Pay particular attention to the wheels, handlebars and seat.
- Only use the bicycle on a **solid and level surface**.
- It is not recommended to cycle on a slope steeper than 10%, this carries an increased risk.
- It is recommended to **drive slowly on slopes**.
- If you stopped on a slope, pull away slowly and if necessary, lean forward to prevent the front wheel from losing contact with the road surface.
- Do you roll backwards on a slope? Brake in doses to prevent the front wheel from losing contact with the road surface.
- The following accessories can adversely affect stability on a slope: rollator holder, stick holder, wheelchair holder or a loaded shopping basket.
- Make sure that no dangerous speed develops on descents. Brake on time and cycle at a moderate speed.
- Be careful not to get baggy pants or loose-fitting clothing caught in the chain, wheels, pedals and other rotating/moving parts.
- Do not use a high pressure or steam cleaner for cleaning.
- Use the parking brake when you park (and leave) the bike. Also use the parking brake to block the bicycle from pulling away when getting on and off. See chapter "**Before use**" for correct use of the parking brake.
- Lock the tricycle at all times if you leave the bike unattended.
- During pregnancy, extra caution is required because of an increased risk of injury.
- Do not put the bicycle in direct sunlight: the temperature of some parts can exceed 41°C. Contact with the skin may cause skin sensitisation.
- Caution: brake discs can become hot during braking. Do not touch the brake discs soon after cycling.
- If pedal assistance is available on the bicycle: practice with the starting aid and the reverse function. When using the bicycle, make sure that the starting aid or the reverse function is not unintentionally activated. For example, if when stopping at a traffic light, the pedals are turned backwards, the reverse function

will be activated and the bicycle will start to reverse. Practice using the reverse and ride away functions. For more information, carefully read the chapter "**Electro system Silent**".

- If a charger is supplied with the bicycle, also read the information under the heading "Charger Safety Precautions" in the "**Electro system Silent**" chapter.



High speeds when cornering and on uneven terrain, or taking too sharp a turn, can cause the tricycle to **tip over sideways**.



**Extra attention** is required if a child or an adult with limited mental perception uses the bicycle.

Before the child or adult with limited mental perception starts cycling independently for the first time, they must first practice on the bicycle under supervision.

Pay particular attention to the steering behaviour, as this can be a great source of danger. Also explain that the widest part of the bike is behind the rider. Let the rider practice passing some obstacles to get a sense of how wide the bike is.

Children or adults with limited mental perception must **always** be made aware again of the possible dangers when using the tricycle.

- **Never** leave a child alone with the bicycle unattended!
- Have a child **always** wear a bicycle helmet! Make sure the helmet fits correctly.
- Have a child wear noticeable, reflective clothing.
- It is recommended to mount a flag on the bicycle that protrudes above the child.

## Tips for safe biking

Make sure you have properly adjusted the bike to the dimensions of the rider, then you can use the bike safely and comfortably.



Riding a tricycle is a completely different experience compared to riding a bicycle with two wheels.

## Important safety points for the rider

- Ride very carefully on the first ride.
- Practice especially cornering and braking, because a tricycle can react in the opposite way from what you would expect.
- Keep your hands on the handlebars and feet on the pedals while riding.
- Test the driving behaviour of the tricycle at an appropriate speed on an uneven surface. This way you learn to react better to unexpected movements of the bicycle and the handlebars during use.
- Explore how the tilting movement of the tricycle responds to body position. Hang to the inside of the turn. Take turns at an appropriate speed.
- Small obstacles must be ridden over at an appropriate speed.
- Obstacles higher than five centimetres should be avoided.
- One of the brake levers operates the brake on the front wheel. Extra caution is required here, because the front wheel can lock if the brakes are pulled too strongly. Practice with phased braking.
- Make sure the brake handles are easy to operate. These can be adjusted to the right distance.

## Check before every ride

Contact your dealer and do not use the bicycle if you notice irregularities during the check!

- Check that the brakes are working correctly. The brakes should work and you should feel pressure on the brake lever.
- Make sure there is enough air in the tires. The tires may be inflated to the maximum pressure indicated on the side of the tire. Tip for extra comfort: You do not have to inflate the front wheel to the maximum pressure, but make sure you always stay above the minimum specified pressure.



- Check that the lights are working correctly. See chapter '**Before use**' for the correct setting of the lighting.
- Check that the seat and handlebars are secure. See chapter '**Adjusting the bicycle**' for the correct adjustment of the seat and handlebars.
- Make sure the battery is sufficiently charged (optional).

As with all mechanical parts, the bicycle is subject to wear and tear and high loads. If a component fails, it can lead to very dangerous situations and to damage or injury to the bicycle user. Any cracks, scratches or change of colour in heavily loaded parts of a component is an indication that the part must be replaced.

### Load

The maximum permissible load must not be exceeded. See the information in the table with technical data under the chapter "**Technical specifications**" in the user manual.

Note that a basket full of luggage can significantly affect driving behaviour (especially on slopes). No luggage may be carried on or hanging from the handlebars that restricts bicycle riding.

### Damaged or worn parts

The replacement and repair of the parts (frame, front fork, lighting, brakes, drive and handlebar) should **always** be carried out by a dealer. Otherwise, the warranty will be void and the user will be liable for any damage.



Safety related parts must **always** be replaced by new parts!



If there is any doubt about the functioning or the condition of components on the bicycle, for example due to visual damage, slack or strange noises, an authorized Van Raam dealer should always be consulted.

## Adjustment of the tricycle

Before you start using the bike, set it to the dimensions of the rider. This is essential, especially for the seat and handlebars.



*If an optimal setting is not possible with the described instructions, you can contact your dealer for a suitable solution.*

The brakes are correctly adjusted as standard and should only be checked and adjusted by the dealer during regular maintenance.



Make sure that fingers and other limbs do not get caught when adjusting the tricycle.

### Easy Rider

#### Seating position

A rule of thumb for adjusting the seating position is the following. The rider sits on the bicycle and puts one foot on the pedal in the furthest position from the rider. Adjust the sitting position so that in that situation the leg is straight, but still relaxed. You determine the most comfortable position yourself in practice.

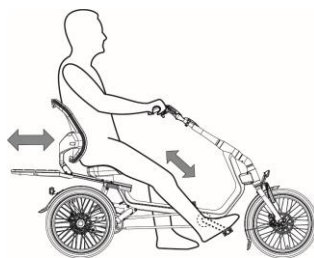

#### Adjusting the seat

To adjust the seat:

1. Open the quick-release lever.
2. Slide the seat to the correct position.
3. Close the quick-release lever.

**Please note!** The luggage tray slides with the seat. Be alert to the tipping behaviour of the bicycle when the platform is fully loaded in the extreme position.

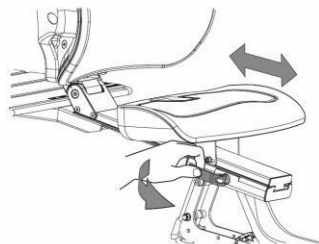



The bicycle is delivered with the correct tension on the lever. The clamping lever therefore does not have to be loosened or tightened.



If the quick-release lever no longer clamps the seat properly, the quick-release lever bolt [A] must be adjusted to the correct tension. You do this by holding the quick-release lever in the closed position tightening the bolt [A] on the other side with a torque wrench (max. 10 Nm). Then check the functioning. The quick-release lever must be manually operable and the seat must not slide when closed. If the seat will no longer slide with an open quick-release lever, the bolt [A] has probably been over-tightened. **If you don't have the right tools or the knowledge, consult your dealer.**

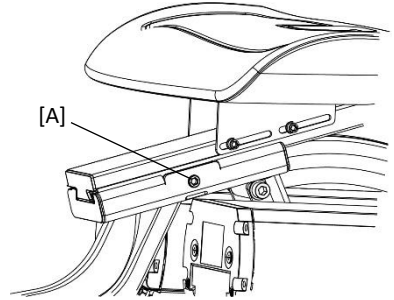

### Backrest position

The backrest can be adjusted to the desired position.

1. Loosen the hexagon bolt [A] a few turns with an Allen key.
2. Adjust the backrest to the desired position.
3. Retighten the hexagon bolt [A].

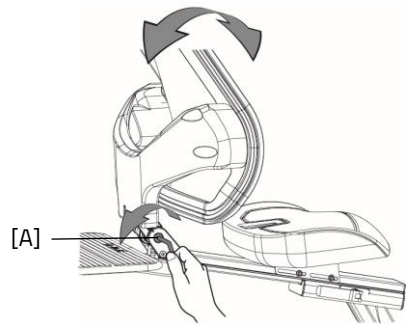

## Easy Rider Compact

### Adjusting the seat

The seat is stepless adjustable over a diagonal range of 150 mm. To adjust the seat:

1. Open the two quick release levers [A].
2. Slide the seat to the correct position.
3. Close the two quick-release levers [A].

**Caution!** Make sure that both quick-release levers are firmly clamped in place at all times.

**Caution!** Make sure the quick-release levers have the correct tension to ensure they are properly clamped in place.

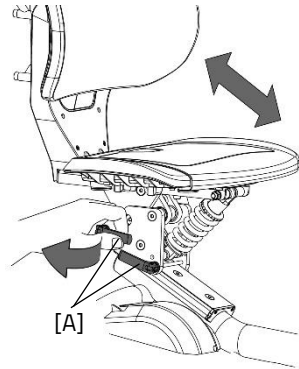

### Adjusting the seat position

It is important that the seat is clamped firmly to the frame. To ensure that the quick-release levers are clamped in place with the correct force, follow these steps:

1. Open the quick-release lever [A].
2. Turn the bolt [B] of the quick-release lever hand-tight.
3. Close the quick-release lever [C].
4. Repeat the above steps for the other quick-release lever [D].

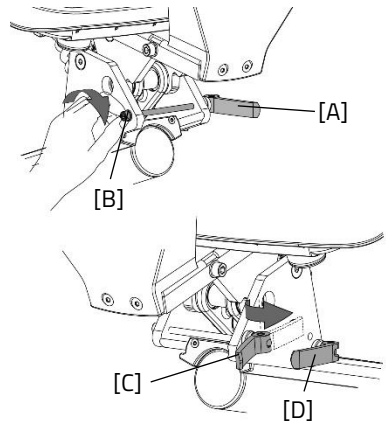

## Adjusting seat depth

The seating area of the seat can be adjusted to tailor the seat to the user's comfort. To adjust the seat, follow these steps:

1. Remove the seat cushion [A] from the seat frame.
2. Now that the seat cushion has been removed, the seat frame can be adjusted in relation to the backrest.
3. To do this, loosen the 4 socket-head screws [B] a few turns.
4. Slide the seat frame forwards or backwards.
5. Tighten the 4 socket-head screws [B].
6. Position the seat cushion by first sliding the front edge over the seat frame. Then press the 4 snap caps into the holes.

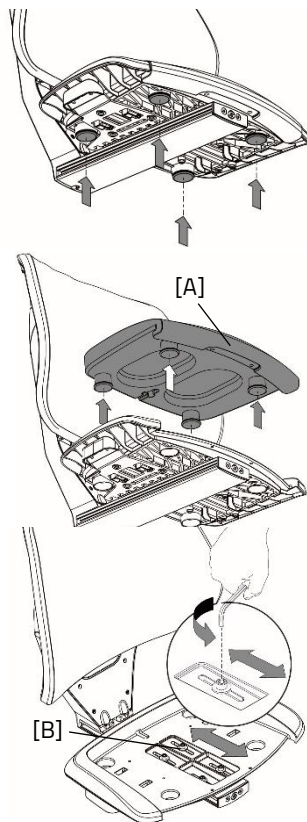

## Carrier frame

A carrier frame [A] is fitted to the backrest of the Easy Rider Compact seat as standard. This is a universal carrier frame on which single-sided panniers can be mounted (frame tube diameter is 12 mm).

The tube clamps [B] prevent the pannier from sliding off the frame. These clamps can be repositioned for a specific pannier. The clamps can be repositioned by using an Allen key to loosen the bolt.

**Caution!** The carrier plate slides with the seat. Watch out for the tricycle's tendency to tip when the carrier plate is fully loaded in its extended position.

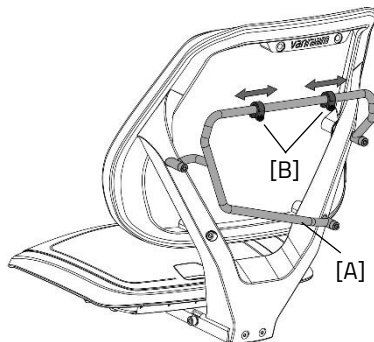

## Handlebar position

### (Easy Rider, Easy Rider Compact)

You can tilt the handlebars. This affects the distance from the handlebars to the upper body. You determine the most comfortable position yourself in practice.

To tilt the handlebars:

1. Press and hold the button [A] on the side of the handlebar stem to release the lever.
2. Open the top [B] of the handlebar stem by raising the lever.
3. Place the handlebars in the desired position and close the top of the handlebar stem.

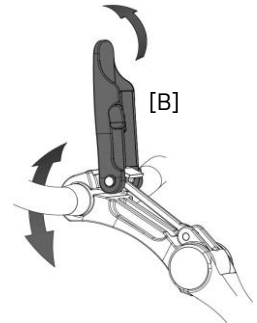
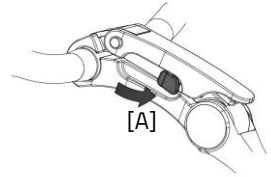

*The bicycle is delivered with the correct tension on the lever. If the bracket does not close properly and the handlebars are not properly secured, the handlebar stem will need to be readjusted. See the chapter 'Repair and maintenance by dealer' for more information.*

## Handlebar height

The height of the handlebars influences the riding comfort. This determines the pressure on the hands and the posture of the back. You determine the most comfortable position yourself in practice.

To adjust the height of the handlebars:

1. Tilt the handlebars to the lowest position as shown in the picture. (Read handlebar position for information on tilting the handlebar stem)
2. The hexagon bolt can be reached by tilting the handlebars downwards.
3. Loosen the bolt [A] with a few turns with an Allen key.
4. Then loosen the parking brake clamp bolts a few turns [B].
5. Slide the handlebar stem to the correct height and then re-tighten the screw.
6. Finally, re-tighten the parking brake clamp bolts [B]. Make sure the parking brake clamp always connects to the handlebar tube [C].

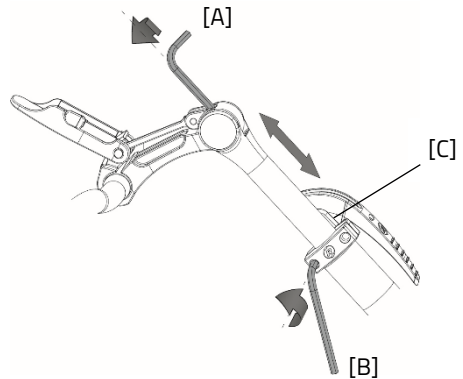

Do not pull out the handlebar stem further than the mark, otherwise the tube will not penetrate deep enough into the shaft and there is a risk of breaking off, which could result in serious injury.



## **Easy Rider Small**

### **Seating position**

A rule of thumb for adjusting the seating position. Consider the following. The rider sits on the bicycle and puts one foot on the pedal in the furthest position from the rider. Adjust the sitting position so that in that situation the leg is straight, but still relaxed. You determine the most comfortable position yourself in practice.

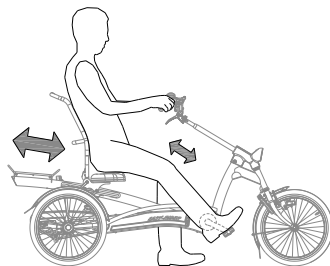

### **Adjusting the seat**

To adjust the seat:

1. Loosen the four clamping levers on the left and right a few turns.
2. Slide the seat to the correct position.
3. Tighten the four clamping levers again.

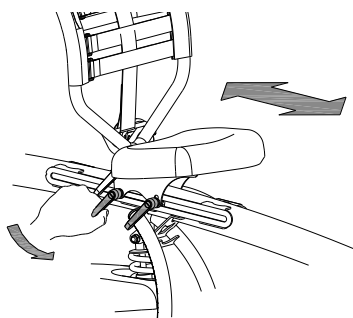

*If the levers are in each other's way, a lever can be pulled out and turned away.*

### **Backrest position**

The backrest can be adjusted to the desired position.

To do this:

1. Loosen the hexagon bolt [A] a few turns with an Allen key.
2. Adjust the backrest to the desired position.
3. Retighten the nut.

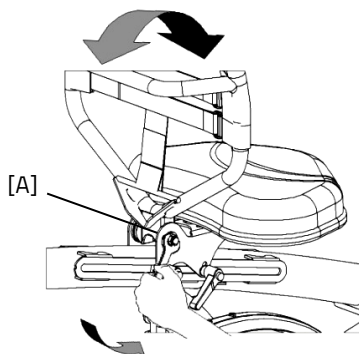



## Backrest firmness

To make the backrest softer or tighter:

1. Open the straps by loosening the Velcro.
2. Tighten or loosen the straps.
3. Re-attach the Velcro.

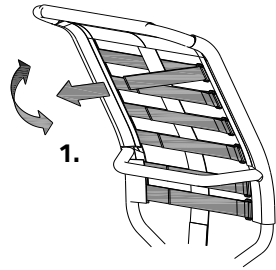

## Handlebar position

You can tilt the handlebars. This affects the distance from the handlebars to the upper body. You determine the most comfortable position yourself in practice. To tilt the handlebars:

1. Loosen the bolt [A] with a few turns with an Allen key.
2. Move the handlebars to the desired position and then re-tighten the screw firmly.
3. Loosen the screw [B] a few turns with an Allen key, return the handlebars to the correct (flat) position and then re-tighten the screw.

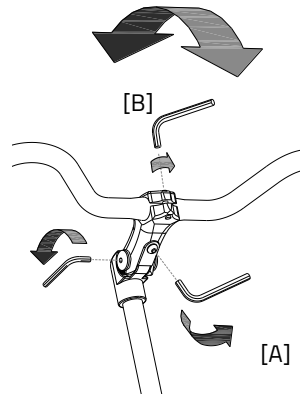

## Handlebar height

The height of the handlebars influences the riding comfort. This determines the pressure on the hands and the posture of the back. You determine the most comfortable position yourself in practice. To adjust the handlebars:

1. Loosen the screw a few turns with an Allen key.
2. Slide the handlebar stem to the correct height and then tighten the screw firmly again.

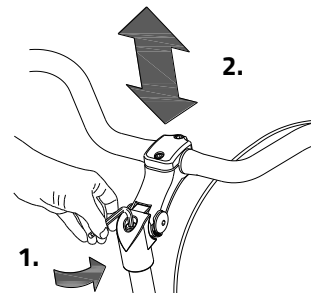



Do not pull out the handlebar stem **further** than the mark. Otherwise, the tube will not penetrate deep enough into the shaft and there is a risk of breakage, which could result in serious injury.



## Before use

### Parking brake

(Easy Rider, Easy Rider Compact, Easy Rider Small)

Always use the parking brake when you park (and leave) the bike. The image shows the parking brake in the parked position.

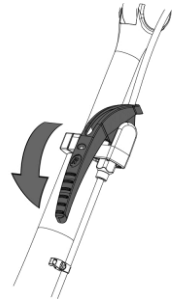

Always try to park the bicycle on a level surface. It is not recommended to park the bicycle on a slope steeper than 10%.

### Lighting

Normally, the lighting on the bicycle can be manually operated and adjusted to different positions. When the bicycle is equipped with the Electro system Silent, the lighting switches on automatically when the electrical system is activated. Below, the operation of both the manually operated lighting and the centrally operated lighting is explained.

## Manually operated headlight

(Easy Rider, Easy Rider Compact, Easy Rider Small)

The headlight has a push button with three positions: ON – ON [50%] – OFF.

Adjust the angle of the headlight so that the center of the light beam is approximately ten meters in front of the bicycle.

The headlight works with batteries. When the batteries are low, a red LED button lights up where the headlight's push buttons are. Follow the steps below to replace the batteries.

1. Open the lamp by pressing down on the lip of the housing and pulling the front of the lamp off.
2. Replace the two alkaline batteries (2x AA).
3. Reassemble the lamp by first pressing the top into the housing and then snapping the bottom back into place behind the lip.

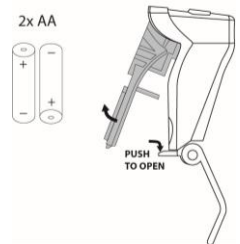
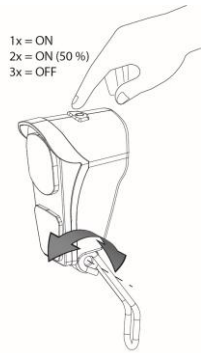

Only operate the lighting when stationary to avoid dangerous situations and the risk of injury.

## Manually operated rear light

(Easy Rider, Easy Rider Small)

The rear light has an on/off button with which **Off-Auto-On** can be set.

The seating is as follows:

*Press 1x lighting is on*

*Press 2x lighting is automatic*

*Press 3x lighting is off*

In the "On/Off" position, the rear light can be switched on or off manually.

In "Auto" mode, the rear light turns on or off automatically using light and motion sensors. If no movement is detected after some time, the lighting will switch off automatically.

The headlight works with batteries. When the batteries are almost empty, a red LED on top of the rear light will flash. Follow the steps below to replace the batteries.

1. Remove the cover from the housing by pressing in the lip on the bottom.
2. Replace the alkaline batteries (1.5 V – 1500 mA) and fit the cover.



*Batteries pollute the environment. When disposing of, please follow local regulations.*

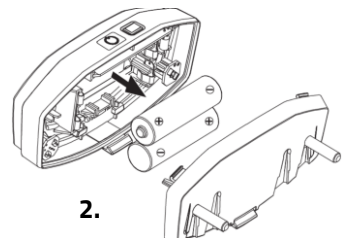
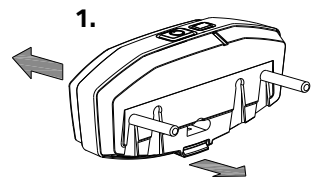
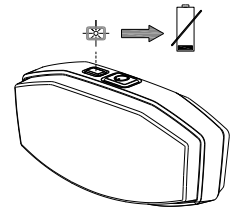
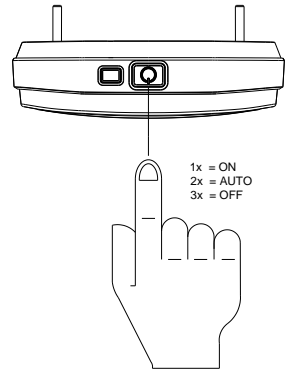

## Manually operated rear light

(Easy Rider Compact)

The rear light can be switched on by using the ON / OFF button underneath.

The rear light works with batteries. When the battery is almost empty, a red LED lights up [B]. Follow the steps below to replace the batteries.

1. Use a flat object [C], such as a coin, to pry off the front of the lamp.
2. Remove the front cover [D] from the housing.
3. Replace the battery [E] at the back of the PCB [E].

Battery type: CR2032

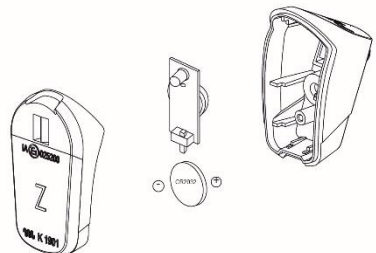

## Centrally operated lighting

(Easy Rider, Easy Rider Compact, Easy Rider Small)

The bicycle is equipped with centrally operated lighting (front and rear) with the lighting connected to the electrical system.

The lighting switches on automatically when the electrical system is activated.

Adjust the angle of the headlight so that the center of the light beam is approximately ten meters in front of the bicycle.

You can switch the lighting on and off manually by briefly pressing the on/off button on the display. When the electrical system is switched off, the lighting switches off automatically.

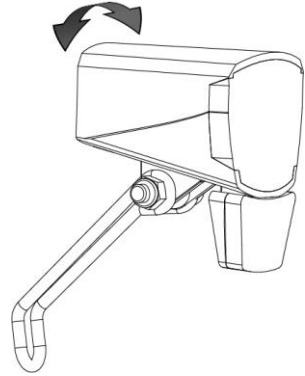

*Make sure that there is always a charged battery on the bike when you go cycling in the dark!*

As soon as the battery is almost empty, the motor no longer provides assistance while cycling. The operable lighting will still work on the residual power.

## Gears

(Easy Rider, Easy Rider Compact)

The bicycle is optionally equipped with gears. The gears are operated by turning the handle. Don't pedal while turning the gears.

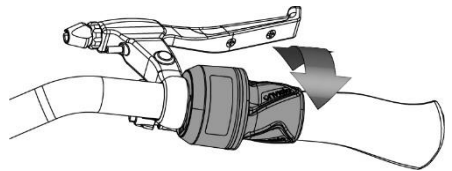

Before you actually start cycling, read the chapter '**Safety Precautions**' and make sure you understand it.

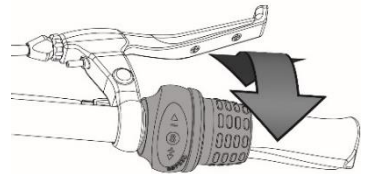

## Silent electro system

The Silent electrical system comprises four components: display, button unit, battery, motor and bottom bracket. How the first 3 parts are used is explained in this user manual.

### Operation of the display

The display provides you with cycling information, which will be explained in more detail later. The display is mounted onto the handlebars by means of a bracket. The display cannot and does not have to be removed when leaving the bike.

(1) On / off

This button switches the electrical system on.

(2) Bicycle lights

The lights on the bicycle switch on automatically when the electrical system is switched on. By briefly pressing this button, the lights can be switched off (and on).

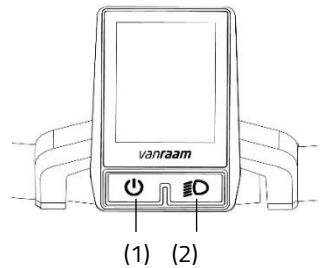

### Operation of the button unit

The button unit is mounted next to the handlebar grip. You use the button unit to operate the electrical system.



*The button unit can be mounted on the other side of the handlebars by your dealer.*

(3) Mode

By pressing this button briefly, you can switch between the different Screen modes.

(4) Plus - Increase pedal support power assistance

(5) Minus - Reduce pedal support power assistance

(6) Start assist

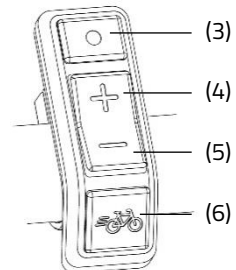

## Information screen

After the electrical system is powered up, the information screen is displayed. This screen displays real-time cycling information.



*The information screen will only work if you have switched on the electrical system.*

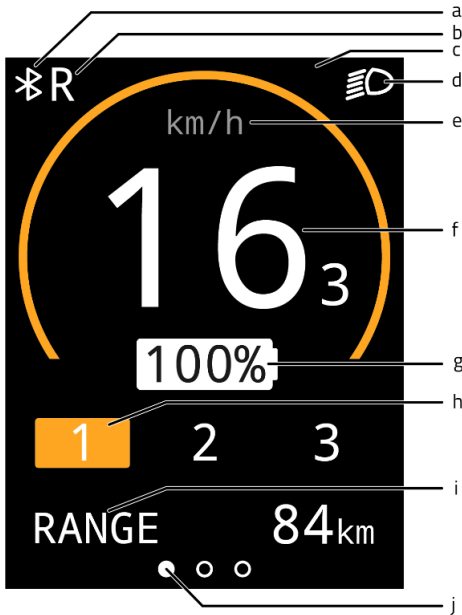

- (a) Bluetooth connection
- (b) Reverse function of (thumb) throttle activated
- (c) Notification field
- (d) Bicycle lights
- (e) Speed indicator
- (f) Speed
- (g) Battery charge percentage
- (h) Assistance mode
- (i) Screen modes
- (j) Screen mode orientation bar



## Screen modes

The screen mode (i) can be set by using the mode button (3) You can switch between the following 3 screen modes while cycling.

1. Radius of action [RANGE] (default display)  
This is the number of kilometres that can still be cycled with the remaining battery capacity in the active assistance mode.



*The range is assistance mode dependent and is an estimate, so the actual range may differ from the estimate. The range is dependent on several factors. Among others, the range is influenced by: battery capacity, amount of assistance, tyre pressure, ride speed, rider weight and load, and the environment.*

2. Trip distance [TRIP]  
This is the distance travelled since the trip odometer was last reset. By holding down the mode button for one second, the trip odometer can be reset to 0.
3. Total distance [TOTAL]  
This is the total distance travelled by the bicycle with the electrical system switched on.



## Settings screen

In the settings screen, the brightness of the display and the units of distance and speed can be changed.

To access the settings screen, the mode button (3) and the plus button (4) should be pressed down simultaneously for one second.

The mode button (3) can be used to switch between the settings. The plus and minus buttons (4, 5) can be used to change the settings.

To exit the settings screen, hold down the mode button (3) for one second.

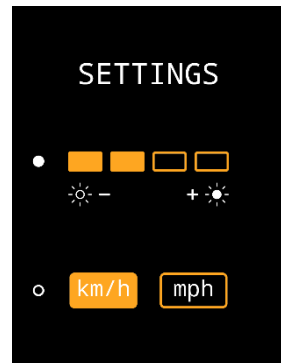

## Notifications

Several symbols may be displayed in the information screen. The symbols are explained below. More information on the notifications can be found in the chapter "**Possible Faults**".



The bicycle lights are activated



A Bluetooth connection is active



No communication with the battery



Reverse function of (thumb) throttle is activated



The temperature of the controller is too high



Voltage is too high



Fault

## Pedal assist

The Silent electrical system provides assistance while cycling.

### Starting aid

With start assist, pedal assist is activated up to a speed of 6 km/h, without having to pedal yourself. To do this, press and hold down the start assist button (6). If the button is pressed again, the function is reactivated.

If you press the start assist button while cycling, you will get a "boost". This boost will have the same maximum speed as the bike. The activated pedal assist mode determines the degree of assistance of start assist and the "boost".

The starting aid button can be used for:

- Extra assistance when starting off (start assist).
- Extra assistance when cycling uphill (boost).

## Assistance settings

The level of pedal assistance can be set using assistance settings 1, 2 and 3. The assistance settings can be changed while cycling.

1. Low level of assistance, maximum range.

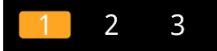

2. Average support, average range.



3. Maximum support, low range.

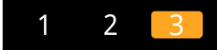

## Reverse pedalling

The reverse function is activated by pedalling backwards from a stationary position. After a few turns of the wheel, the motor is activated and the bicycle will reverse at the speed of 3 km/h for as long as it is pedalled backwards.



Do not let the electric motor's sudden behavior take you by surprise. For example, if while waiting at the traffic lights you playfully pedal backwards, the reverse function will be activated and the bike will start riding backwards!

## Presets

A preset is a set of settings which sets the level of assistance. By loading a different preset, the level of assistance for all assistance modes can be adjusted. Presets can be changed by the dealer or through the Van Raam app.

## Van Raam e-Bike app

With the Van Raam e-bike app, you can track a variety of information and configure the assistance settings. Information on this can be found in the **chapter on the Van Raam E-Bike app**.

## Operation without battery

In case the battery is dead or there is no battery on the bike, the bike can be cycled and the gears work.

## Charging the battery

### (Easy Rider Compact)

To remove the battery from the Easy Rider Compact and charge it, follow these steps:

1. Unlock the battery by turning the key a quarter turn.
2. Push the lock in.
3. Slide the battery pack a few centimetres out of the holder.
4. You can now lift the battery off. Use two hands for this if necessary.
5. Take the battery inside with you. **First** plug the charger into the power outlet. The green LED will light up. The charger is now on standby.
6. **Then** plug the charging connector of the charger into the charging point of the battery. The red LED will light up. The charger is now charging.



**Caution!** If the battery is not properly connected, then the green LED will be on (standby mode). In case of an unsatisfactory connection, unplug the charger from the power outlet and clean its connector with a dry cloth.

7. The charging time depends on the battery status. The charging time is approximately 2 hours for a 11.4 Ah/36 V battery and approximately 4.5 hours for a 24.8 Ah/36 V battery.
8. As soon as the battery is fully charged, the green LED will light up continuously. Now **first** remove the charging connector from the battery.
9. **Then** remove the charger's plug from the power outlet.

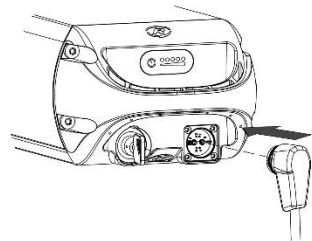
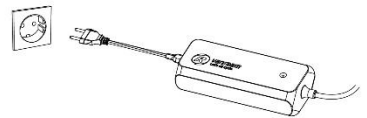
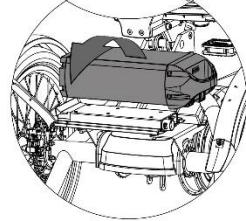
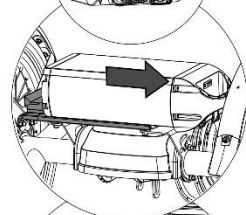
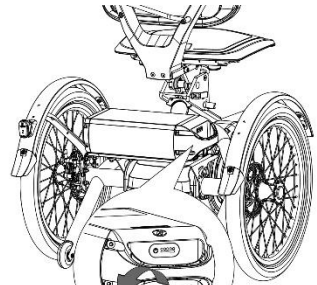

- Place the battery back into the holder on the bicycle and lock the battery. Optionally, the battery can also be charged directly in the holder.

## Charging the battery

(Easy Rider, Easy Rider Small)

For optimal condition and capacity of the battery we recommend that you charge the battery inside at room temperature.



Only use the charger when the ambient temperature is between 0 and 35 degrees.

To charge the battery indoors, follow steps 1 to 9. To charge the battery on the bike, follow steps 4 to 8.

- Unlock the battery by turning the key a quarter turn.
- Press on the lock and hold it down. Then pull the battery out of the holder with the other hand.
- Take the battery inside.
- First** plug the socket into the power outlet. The green LED lights up. The charger is now on stand-by.
- Then** plug the charging connector of the charger into the charging point of the battery. The red LED lights up. The charger is now charging.



**Please note!** If the battery is not properly connected, the green LED is on (standby mode). If the connection is insufficient, remove the plug from the socket and disconnect the connector from the charger with a dry cloth.

- The charging time depends on the battery status. The charging time is approximately 2 hours with a

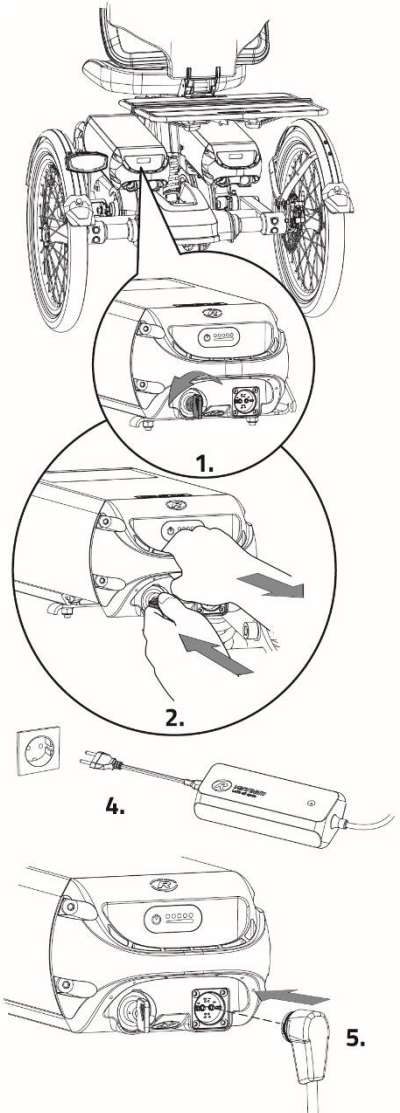

11,4 Ah/36 V battery and approximately 4.5 hours with a 24,8 Ah/36 V battery.

7. As soon as the battery is fully charged, the green LED lights up continuously. **First** remove the charging connector of the charger from the battery connector.
8. **Then** remove the charger's plug from the socket.
9. Place the battery back into the holder on the bicycle and lock the battery.

### Charger indicator light

The status of the charger is indicated by the coloured indicator light.

- If the indicator light is green, the charger is in standby mode or the battery is full.
- If the indicator light is red then the charger is charging the battery.
- ⊘ If the indicator light flashes red then the charger is in safety mode.

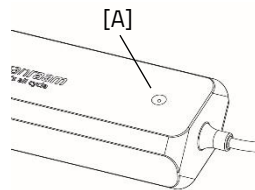

**Caution!** Unplug the charger from the power outlet.



Only use the charger when the ambient temperature is between 0 and 35 C.



It is better for the battery to be charged periodically instead of waiting until it is completely empty.

## Battery indicator lights

There is an LED indicator on the battery pack for checking the battery charge status. The battery charge status can be read by briefly pressing the on/off button [A]. While the battery is being charged, the indicator shows the charging progress:

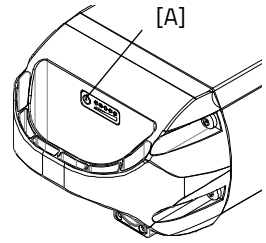

The battery is fully charged. When the battery is used, the number of green lamps will decrease.



If two green lamps are lit, the battery is 50% charged.



If only the left LED remains green, the battery is almost empty and needs to be recharged or replaced with a charged battery.



If the left LED starts blinking green, the battery is empty and the motor will not support cycling for much longer. However, the switchable lighting will still work after that.



Never put the bike away with an empty battery.

## Deep sleep battery mode

When the battery is almost empty and has not been used for a week, the battery will go into a "deep sleep mode". In this mode, the battery uses as little energy as possible, which extends the battery life.

When "deep sleep mode" is activated, the battery cannot be used. By pressing the on/off button [A] on the battery, the battery will be released from "deep sleep mode" and can be used again. It is advisable to charge the battery before using it.

## Charging and maintenance of the battery pack

Important safety warning:

- To ensure the battery's optimal condition and capacity, we recommend charging it indoors at room temperature.
- Never put the bicycle away with an empty battery. We recommend charging the battery as soon as possible when it is empty. The best storage charging level for the battery is when the charge display shows three to five LED lights.
- In winter, check the battery charge every other month, recharge it if fewer than three LEDs light up.
- Preferably store and use the battery between 5 and 20 C, avoid higher and lower temperatures.
- Do not charge the battery in direct sunlight and make sure that the battery is not charged at a temperature lower than 5 C.
- Only use the charger in dry indoor areas, the charger must not get wet.
- Only use the supplied Van Raam battery and charger.
- The housing of the battery and the charger must not be opened. In case of any problems, please consult your dealer.
- A Van Raam battery should not and cannot be reconditioned for reasons of safety and incorrect functioning of the electrical system.
- Do not drop the battery as this can cause external and internal damage.
- If the bicycle malfunctions, the battery must be disconnected from the bicycle.



*Keep in mind that the bike provides less assistance at lower temperatures (0°C and below) and that the battery will drain more quickly. It also takes longer to charge at low temperatures.*



*Every battery drains over time. This process is called 'self-discharge'. A battery that is empty and not charged can undergo a deep discharge caused by self-discharge and become faulty as a result. The warranty is voided in the case of a deep discharge.*



*Keep in mind that every battery wears out over time. The wear and tear process of the battery is inevitable and depends on several factors such as use, the number of times it has been fully discharged and charged and the ambient temperature. Even if the battery is not used, its capacity will decrease. A worn-out battery can be used, but keep in mind that the range will be reduced.*



## Possible malfunctions

- The system cannot be switched on:
  1. Check that the battery is attached properly.
  2. Check the status of the battery. If it is empty, charge the battery.
  3. If the above does not provide a solution, please contact your dealer.
- If a red LED flashes on the charger, unplug the charger from the power outlet and stop using the charger and battery. In such a case, contact your dealer.

### Table of fault notifications in the information screen:

Fault symbol/ code	Description	Consequence/ course of action
All assistance modes are flashing	Temperature controller too high	System does provide assistance, motor power is reduced.
Thermometer (symbol) + all assistance modes are flashing.	Temperature controller too high	System does not provide assistance, let the controller cool down.
Battery with cross (symbol) + all assistance modes are flashing	No communication with the battery	System does provide assistance. Contact your dealer.
Lightning bolt (symbol) + assistance settings are turned off	Voltage too high	System does not provide assistance, voltage drops automatically when cycling speed is slower than maximum assistance speed.
Exclamation mark (symbol)	Voltage too low	System does not provide assistance, check the connection between controller and battery. Check how full the battery is.
	Controller communication error	System does not provide assistance. Contact your dealer.
Active assistance mode is flashing	Electrical current too high	System does not provide assistance. Contact your dealer.
Active assistance mode is flashing	Motor sensor fault	System does provide assistance. Contact your dealer.
All assistance modes are turned off.	The battery is almost empty.	Charge the battery.

## Charging and maintenance of the battery pack

Important safety warning:

### Charger safety precautions

- Only charge Van Raam Li-Ion batteries with the supplied charger. Only connect the charger to a suitable wall socket (220–240 Volt AC 50–60 Hz). When the charger is not in use, disconnect it from the power outlet and the power plug from the battery.
- The charger may only be used by persons who have read the information in this manual and are familiar with the correct use of the charger. Keep the charger out of reach of children; they should not play with the charger.
- The charger is designed for use in a dust-free, dry and ventilated environment. Do not expose the battery to water, heat sources and direct sunlight. Keep the charger clean and dry.
- Do not charge batteries that feel hot. The battery may only be charged in places where the temperature is no higher than room temperature. Stop charging if the battery becomes abnormally warm ( $> 40^{\circ}\text{C}$ ).

**Caution!** The charger can become warm during charging  $> 50^{\circ}\text{C}$ . First, carefully feel whether you can pick up the charger, this temperature can cause hypersensitivity or a reaction of shock when it comes into contact with the skin.

- Do not use the charger if it is visibly damaged or modified. Do not repair the charger yourself! Please contact Van Raam. You are strictly prohibited from opening the charger yourself!
- Always keep an eye on the charger and battery while charging. When the battery is full, disconnect the power plug from power outlet and remove the power plug from the battery.

## Silent Electrical System options

For each bicycle model, there are different options for the electrical system.

### External charging point

(Standard for Easy Rider, optional for Easy Rider Compact and Easy Rider Small)

The Easy Rider is equipped with an external charging point in the backrest. This enables the battery to be charged via an easily accessible charging point without having to remove the battery from the bicycle.

The external charging point is optional for the Easy Rider Compact and the Easy Rider Small.

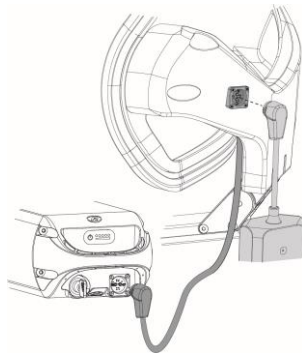

*If the battery fails to charge, check whether the power plug of the external charging point is properly connected to the battery.*

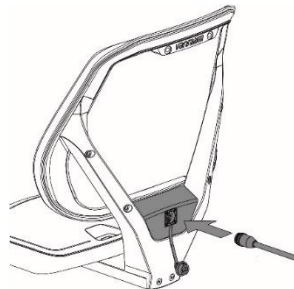

### Backup battery (optional)

(Easy Rider, Easy Rider Small)

The bicycle can be equipped with a second battery. As soon as the connected battery is empty, swap the batteries.

One battery holder is connected to the system, recognisable by the cables.

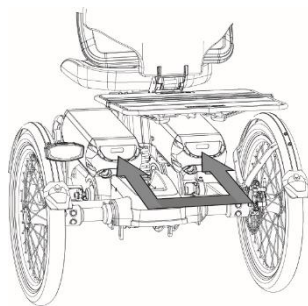

## Switchable battery pack (optional)

(Easy Rider, Easy Rider Small)

If you have two batteries, the bicycle can be equipped with the switchable battery pack option. As soon as the connected battery is empty, you can change batteries using a switch. This is located under the seat, carrier or battery.

Both battery holders are connected to the system. If desired, you can leave the empty battery out of the holder in the meantime to charge the battery.

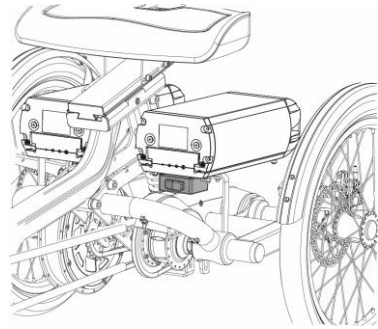

## Thumb throttle

The bike can be equipped with a thumb throttle. The thumb throttle is mounted next to the handlebar and can be operated with the thumb. When the throttle is operated, the bike will start riding up to a maximum speed of 6 km/h without the need to pedal along.

The switch on the thumb throttle can be used to switch between forward and reverse riding. When the switch is set to '0', the bike will start riding forward as soon as the thumb throttle is operated, and when the switch is set to '1', the bike will ride backwards at a maximum speed of 3 km/h.

## Direction Indicator

The bike can be equipped with a direction indicator. To operate the direction indicators, press switch [A] on the handlebar to the left or right. When the direction indicator is active, a clicking sound can be heard. To deactivate the direction indicator, you need to set the button to the middle position. The direction indicator is powered by the battery of the Silent Electric System.

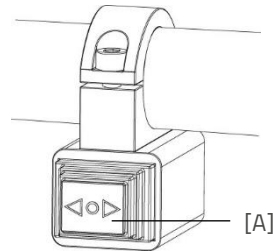

*Please note that the turn signal can only be activated when the bicycle's lighting is turned on.*

## Van Raam e-bike app

The Van Raam bicycle app is a free smartphone app that you can use while cycling on your electric Van Raam bicycle.

### What can you do with the Van Raam e-bike app?

- App can be used as a luxury bicycle computer
- Change bike settings
- Send SOS messages with GPS location to a number of your choice
- View cycled routes
- View information about the bike

### How does the Van Raam e-bike app work?

With the Van Raam e-bike app, a connection can be made with the display via Bluetooth connection. As soon as the display is ready to connect to the smartphone, the on/off button will briefly turn blue.

This app can be used as a luxury bicycle computer for Van Raam bicycles with pedal assistance and also contains many other extra functionalities. The dashboard on the app shows the current speed, total distance, trip meter, battery capacity and power consumption during the bike ride. For more cycling data, there is a details screen including average speed, maximum speed, total distance, power, battery voltage, pedaling power and pedaling frequency.

The Van Raam e-bike app can be downloaded free of charge from the **Google Play Store** or **Apple App Store**.

For more information about the Van Raam e-bike app, you can visit the Van Raam website: [www.vanraam.com](http://www.vanraam.com).



## Options

### Removing the seat for transport

(Easy Rider, Easy Rider Compact)

With the Easy Rider it is possible to detach the seating. This is a standard function that is present on every Easy Rider 3. By removing the seat, transporting the bike on a carrier might become easier. **Caution!** It is important to always check the maximum loading weight of your bike carrier and to not exceed this limit. Specifications of the Easy Rider can be found in the chapter '**Technical Specifications**'.

### Removing (and transporting) the Easy Rider seat

In preparation, line up the bike with the bike carrier while it is installed on the vehicle. This to allow for a smooth transition onto the carrier. Then follow these steps:

1. Engage the parking brake, remove any objects from the basket and remove any other loose objects that may fall off the bike.
2. In case you have an Easy Rider with pedal assist, first remove the charging cable. This is the cable leading from the battery to the external charging point in the seat.
3. To detach the seat, you need to remove the screw under the seat with an Allen key (size 4). **Please note!** Store this screw in a secure place as you will need the screw once you place the seat back onto the bike.
4. Open the quick release pin on the side of the seat and pull the entire seating unit backwards to remove the seat from the bike.
5. You can now store the seat and the battery in the vehicle, and you can place the bike on the bike carriage.

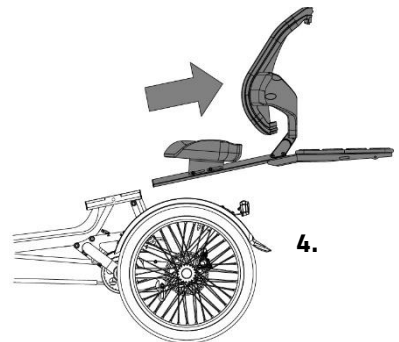
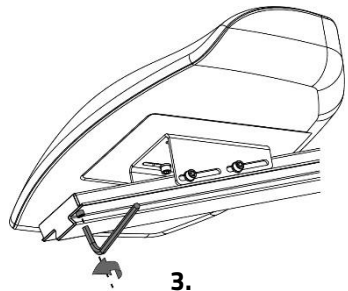



*It is not possible to directly purchase a bike carrier for your Van Raam bike at Van Raam. There are several manufacturers that are specialised in making custom bike carriers, roof carriers or storage solutions for your bike. Please refer to the Van Raam website for more information.*

### **Removing (and transporting) the Easy Rider Compact seat**

For the Easy Rider Compact, do the following:

1. Put the bike on the parking brake, if necessary remove the bag from the carrier frame and any other parts that may fall off the bike.
2. In the case that the backrest has the external charging point option, first remove the charging cable from the battery.
3. To remove the seat from the bike, first unscrew the end fastener [A] from the seat slider. Do this by unscrewing the two screws [B] with a Torx screwdriver.
4. You can now remove the seat [C] from the bike.

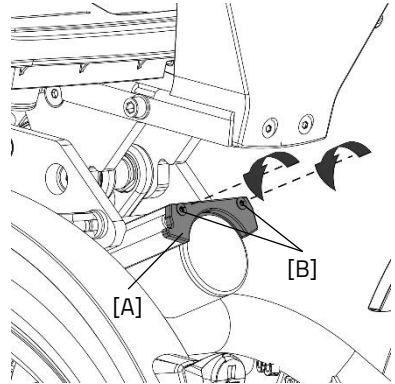

*Caution! After fitting the seat back on the bike, always make sure that the end fastener [A] is remounted. This part ensures that the seat is not mounted too far back, which would create major safety risks.*

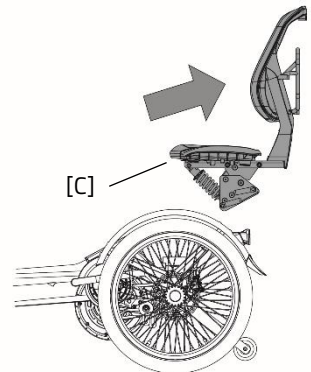

Do you have extra options on your bike? Some of these options are explained below. Additional options are available through a Van Raam dealer.

Do you have extra options on your bike? Some of these options are explained below. Additional options are available for purchase through a Van Raam dealer.

### Easy Rider divisible frame

Follow these steps to divide the frame:

1. Turn off the pedal assist.
2. Open the Velcro straps [A] of the cables.
3. Unplug the connector [B] of the lights.
4. Remove the handle [C] from the handlebars. Press on the balls of the spring to pull the handlebar outwards. Put this handle on the luggage rack and secure in place with the binders.
5. Turn the star knob [D] until it does not turn any further.

**Please note!** Do not push the star knob down yet.

6. Support the front of the bike by holding the steering tube [E], and slightly pull the front upwards.
7. With your other hand push on the star knob [D] to disengage the connection. **Please note!** Do not push the star knob without supporting the front of the bike.
8. You can now slowly lower the front [E] of the bike. **Tip:** do not put the bike on the parking brake so the front easily rolls forward. **Tip:** Lay down the front of the bike on a soft surface to prevent damage.

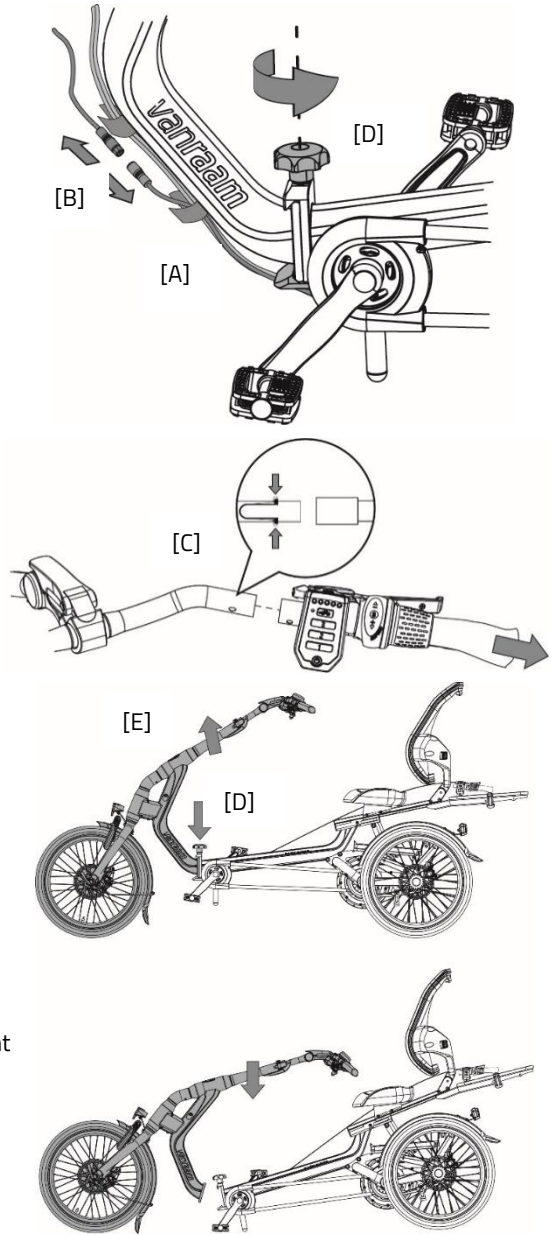



To put the two parts of the bike back together follow these steps:

**Tip:** do not put the bike on the parking brake, this makes it lighter.

1. Make sure the star knob [D] is completely turned loose.
2. Clamp the front of the bike into the frame connection [F].
3. Lift the front [E] of the bike to connect the bike (leverage effect) .
4. Tighten the connection by turning the star knob. Slightly lift the front of the bike to make sure the connection is flush. **Please note! Make sure the connection is flush and the knob is completely tightened before using the bike.**
5. You can now put the handle back on the handlebars.
6. Connect the connector of the lights. Make sure that the two white lines [G] are lined up with each other.
7. Finally, you can now secure the cables in place using the Velcro straps [A].

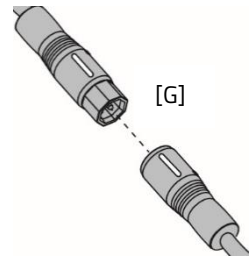
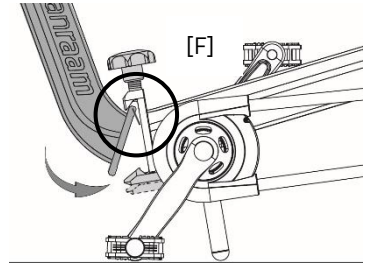

### Crank shortener

(Easy Rider, Easy Rider Compact, Easy Rider Small)

The crank shortener is attached to the crank (as shown). The pedal can then be mounted in two positions in the crank shortener.

With the adjusting screw [A], the crank shortener should be aligned with the crank.

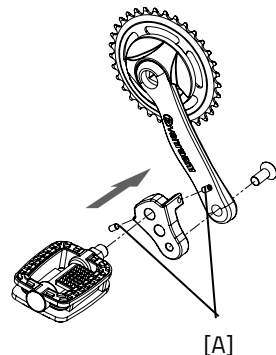

### Stick holder Easy Rider

You can take two sticks with you in the stick holder. Place the stick in the holder at the bottom [A] and then press the stick into the clips [B]. Secure the stick(s) by hooking the ball [C] on the end of the elastic into the clamp.

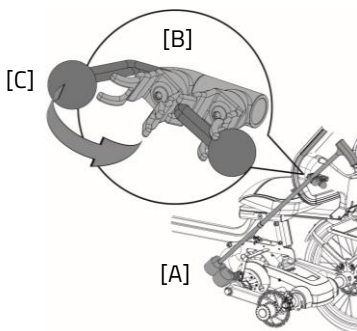

### Stick holder Easy Rider Compact

You can take two sticks with you in the stick holder. Place the stick in the holder at the bottom [A] and then press the stick into the clips [B]. Secure the stick(s) by hooking the ball [C] on the end of the elastic into the clamp.

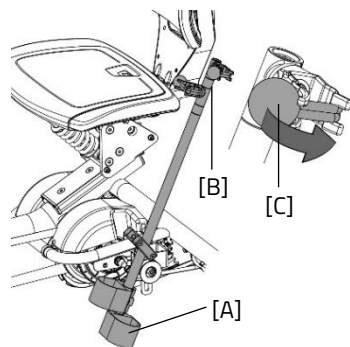

### Stick holder Easy Rider Small

You can take two sticks with you in the stick holder. Place the stick in the holder at the bottom [A] and then press the stick into the clips [B].

Always secure the stick(s) with the Velcro.

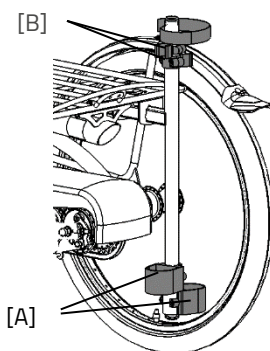

## Foot fixation

(Easy Rider, Easy Rider Compact, Easy Rider Small)

With the foot fixation you can fix the foot by sliding the two notched straps [A] into the quick releases [B].

The quick release can be unlocked by pulling the lip back completely. The notched strap can then be pulled out.

The notched straps can be cut to size. The strap must maintain an excess length of at least five centimeters.

The position of the foot fixation on the pedal is adjustable in length. This allows you to pedal with the ball of the foot to apply optimal force.

1. Loosen the four nuts a few turns with a socket wrench.
2. Move the plate, including the footrest, forwards or backwards into the desired position. The re-tighten the nuts.

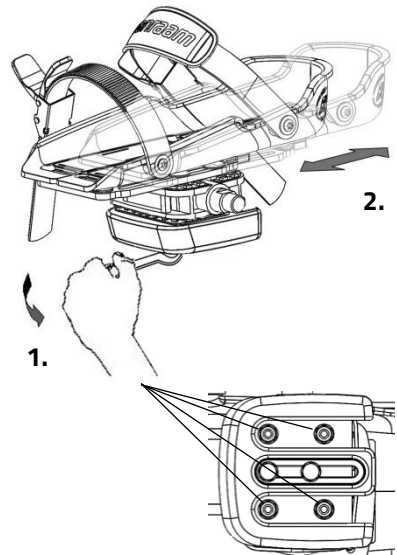
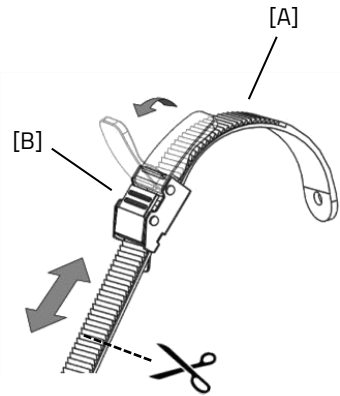

The foot fixation returns to its neutral position when not in use. The neutral position can be determined by sliding the balance block.

1. Loosen the two nuts a few turns with a socket wrench.
2. Slide the balance block into the desired position. Then re-tighten the nuts.

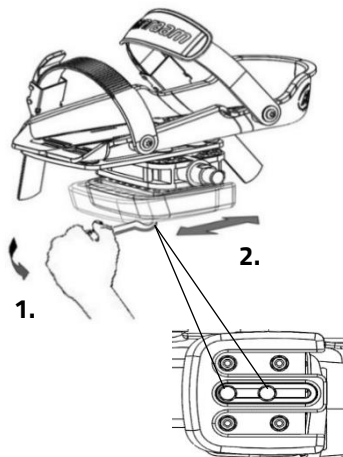

The footrest is also adjustable in width. Only the outer footrest can be moved.

1. Loosen the two bolts a few turns with an Allen key.
2. Move the footrest half to the desired position. Then re-tighten the nuts.

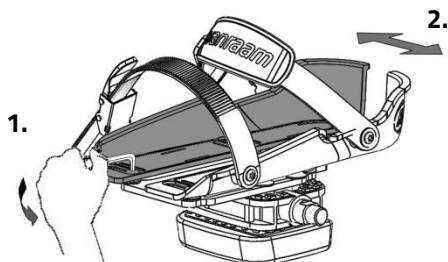

With the pedal extension, the footrest halves can be pushed further apart.

**Tip:** When adjusting the footrest, bring the rear parts together in a V-shape. This will give you a better fit, as a foot is narrower at the back than the front.



*The small footrest (Fix20) is suitable for size 22 to size 36. The width of the reach of this footrest is min. 6.5 cm to max. 9 cm. The large footrest (Fix25) is suitable from size 37 to size 48. The width of the reach of this footrest is min. 8.5 cm to max. 13 cm.*

## Lower leg fixation

(Easy Rider, Easy Rider Compact Easy Rider Small)

With the lower leg fixation option, you can fix the lower leg. To adjust the lower leg strap:

1. Loosen the bolt [A] a few turns with a wrench. Adjust the height of the lower leg fixation so that it matches the rider's lower leg. Then re-tighten the bolt.
2. Loosen the two nuts [B] a few turns. The angle of the leg cup can now be adjusted. Rotate the leg bowl to the correct position and then retighten the nuts.
3. Use the Velcro to secure the lower leg.

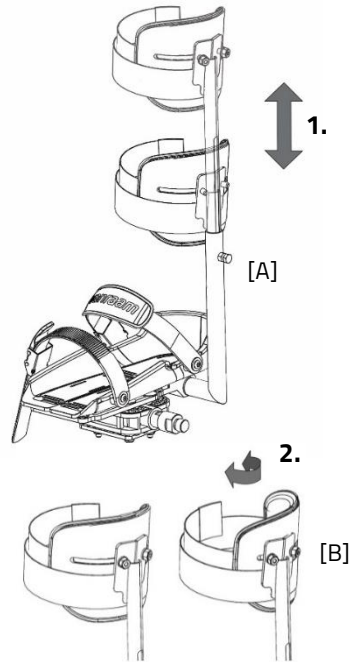

## Walker holder

(Easy Rider, Easy Rider Small)

The walker holder adapter can be adjusted in height. To adjust, the bolt [A] must be loosened a few turns with an Allen key. Now the adapter can be adjusted to the desired height. Then re-tighten the bolt [A].

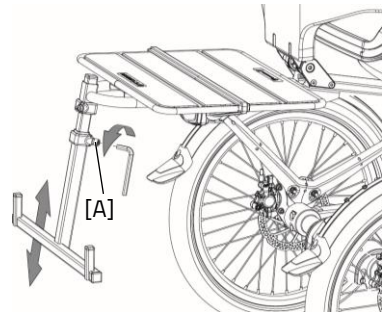

*The image differs from the Easy Rider Small.*



Pay attention to the maximum luggage weight. The 20 kilos on the carrier includes a walker. Do not exceed this weight and be aware that this option affects the tipping behaviour.

## Armrests

### (Easy Rider, Easy Rider Compact)

The armrests are individually foldable and can also be adjusted to different heights for the Easy Rider.



*The armrest must not be loaded with more than 20 kg.*

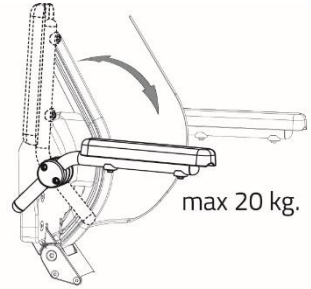

To adjust the armrests to the correct height (Easy Rider only):

1. Unscrew the two hexagon bolts [A] a few turns with an Allen key.
2. The armrest can now be adjusted to the desired height. Then re-tighten the bolts.

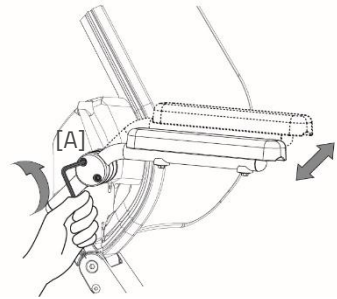

## Floating pedal

### (Easy Rider, Easy Rider Small)

The floating pedal can be set to different positions. To do this, the hexagon bolt [A] must first be loosened a few turns with an Allen key. The floating pedal can then be adjusted to the desired height. Then re-tighten the bolt.

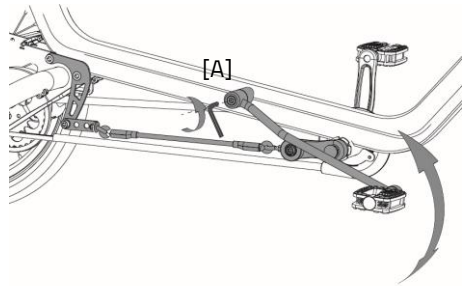

*The image differs from the Easy Rider Small.*



*When rolling backwards and dismounting the bicycle, the floating pedal can kick back. Be aware that in this situation, the pedal may come into contact with the leg.*

## 4-Points belt

(Easy Rider, Easy Rider Small)

To open the belt, the buckle button [A] must be pressed. Then the buckle can be pulled apart. The 4-points belt is adjustable in length. This can be done by loosening the belt clips [C] on the back of the backrest. Now the desired length of the belt can be set using the buckle [B]. Then close the belt clamps [C] again. With the clamp buckle [D] you can tighten or loosen the belt.

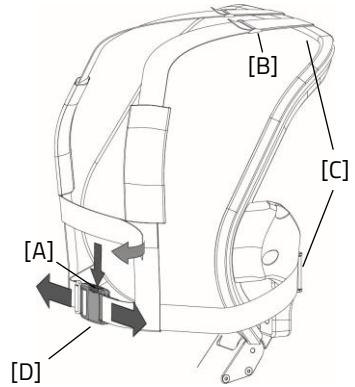

## Gear lever

(Easy Rider, Easy Rider Compact, Easy Rider Small)

The position of the gear lever can be determined based on the position of the shifter and the user's preference. To adjust the lever, the bolt [A] must be loosened a few turns with an Allen key. Now the lever can be adjusted to the desired position. Then tighten the bolt so that the lever clamps around the shifter sufficiently. **Please note!** Do not tighten the bolt more than necessary.

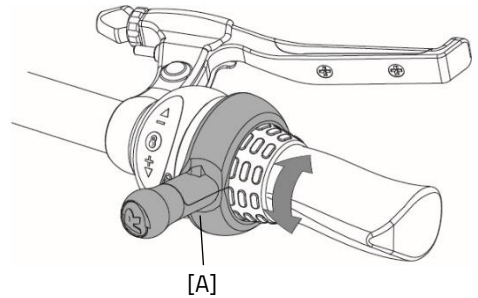

## Bicycle trailer adapter Easy Rider

The bicycle trailer adapter bracket [A] is fitted to the swingarm on the rear of the bike. On this bracket, the adapter of your bicycle trailer [B] can be mounted. The width of the bracket is similar to that of a hub adapter on a regular 2-wheeled bike.



*The adapter [B] is not included with this option. The adapter can differ from the one in the images.*

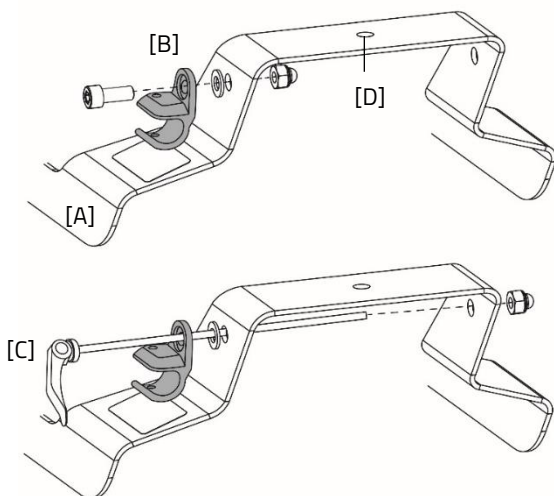

The adapter of your bicycle trailer [B] can be attached to the bracket using the parts provided with the bracket. In case you have a quick release mechanism [C], this can also be used with the bracket. In case your bicycle trailer has a ball joint connection, it can be mounted on point [D].



*Make sure you thoroughly read the user manual of your bicycle trailer and they comply with the manufacturer's instructions before use.*



*Max total loading capacity of 45 kg.*

## Safety flag

**(Easy Rider, Easy Rider Compact)**

To remove the safety flag, follow the following steps:

1. Loosen the cap nut [A] a few turns with a socket wrench.
2. Loosen the Allen bolt [B] of the backrest.
4. The safety flag can now be removed.
5. Finally, tighten cap nut [A] again.

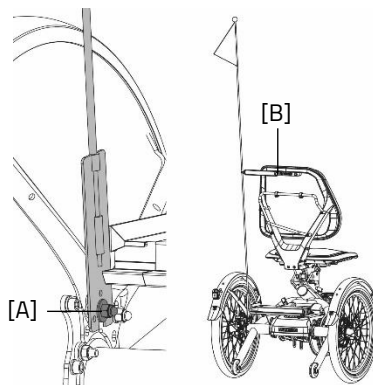



## Technical specifications

	Easy Rider Medium	Easy Rider Large	Easy Rider Compact	Easy Rider Small
<b>Inside leg length (cm)</b>	65-88	85-108	63-81	47-73
<b>Length (cm)<sup>1</sup></b>	225	242	174	175
<b>Width (cm)</b>	78	78	73	75
<b>Height (cm)</b>	116	116	109	102
<b>Entry height (cm)</b>	35	35	32	approx. 34
<b>Front wheel</b>	20"	20"	16"	16"
<b>Rear wheel</b>	20"	20"	20"	16"
<b>Weight (kg) configuration without electrics</b>	49 (with seat)	51 (with seat)	39 (with seat)	36
<b>Max. weight of user (kg)<sup>2</sup></b>	140	140	100	80
<b>Max. load carrier plate or carrier frame (kg)</b>	20	20	10	20
<b>Brakes, front</b>	Mechanical disc brakes with parking brake function	Mechanical disc brakes with parking brake function	Mechanical rim brake with parking brake function	Mechanical rim brake with parking brake function
<b>Brakes, rear</b>	Hydraulic disc brakes or back-pedal brakes	Hydraulic disc brakes or back-pedal brakes	Hydraulic disc brakes	Hydraulic disc brakes or back-pedal brakes
<b>Suspension (lbs/inch)<sup>3</sup></b>	550 / 750* / 1000	550 / 750* / 1000	550	750

<sup>1</sup>Length (cm) of the standard version. Due to possible adjustments to the bike, the length may vary.

<sup>2</sup> This applies to the standard frame. The frame of the Easy Rider can be reinforced and made to measure. This cannot be done with the Easy Rider Small and the Easy Rider Compact.

<sup>3</sup>The suspension with an \* is fitted as standard. More information about determining the correct suspension for the Easy Rider and replacing the suspension can be found in the chapter '**Repair and maintenance by the dealer**'.

## Cleaning and maintenance by owner

Below are instructions for maintenance and adjustments that you can carry out yourself on a regular basis. This keeps the condition of the bicycle optimal.

### Cleaning and disinfection

The frame of the tricycle can be cleaned with a damp cloth. You can use a mild detergent for dirty spots.

The wheels can be cleaned with a damp brush with plastic bristles (no wire brush!) The saddle, the handles and the backrest can be disinfected with mild soap and water.



Do not use a high pressure- or steam cleaner!

### The right lubricant

The chain should be cleaned and preserved regularly (approximately every three months). Only use special chain grease or Teflon spray. This is the only way to ensure that the chain runs smoothly, remains water resistant and does not rust.

1. Wipe the chain with a cloth.
2. Treat the chain with grease or spray.
3. Rub off excess lubricants with a cloth.

Other parts should **not** be treated with a lubricant.

### Inspection of the tricycle

It is necessary that the tricycle is inspected at least annually by a dealer in order to be able to continue to claim under the warranty. Use the "Service, maintenance and modifications form" at the back of this manual. The first service should be carried out after the first 200 kilometres or after two months.

In case of malfunctions or defects, **immediately** contact the dealer for repairs.

The replacement of safety-related components (especially frame, brakes, lighting, handlebars, front fork and drive) must be carried out by your dealer.

If you do want to replace components yourself, you are liable for damage or injury as a result of incorrectly mounted components.

Only use **original** Van Raam spare parts, you can purchase these from your dealer. Upon request, the dealer will provide the necessary information for repair and maintenance.

## **Repair and maintenance by dealer**

During the service, check the brakes, rims, lights, chain tension and spokes. Also check the tread depth of the tires. This must be at least one millimetre. Worn tires or any defective parts must be replaced. Check the operation of the parking brake. With the fixed parking brake applied, the tricycle with rider on it may not ride away.

### **Checking the rim**

Due to the interaction of both the brake and the rims, not only the brake lining, but also the condition of the rim is important. For this reason, the rim should be checked at regular intervals, for example when inflating the tire. The presence of fine cracks in the rim flange at the spoke nipples or deformation of the rim with increased air pressure in the tire indicate greater wear. In that case, the rim must be replaced, because otherwise this can lead to a reduction in the braking effect or even a break in the rim with all the dangerous consequences that entails.

Repairs, maintenance and modifications may only be carried out with original Van Raam parts.

## Tightening torques

Part	Moment
Handlebar stem bolt Easy Rider Small	21-23 Nm
Handlebar bolts Easy Rider Small	12-14 Nm
Silent smart display mount bolt	1 Nm
Silent smart button unit bolt	0,4 Nm
Headset bearing handlebar	Free of slack
Headset bearing front fork	Free of slack
Swingarm mounting bolts	70 Nm
Motor nuts	50 N
Bottom brakcet bolts	30 Nm
Crank bolts	37 Nm
Calliper bolts	10 Nm
Wheel bolts	30 Nm
Wheel nuts	37 Nm
Bolt quick-release lever seat adjustment	10 Nm
Chest bolt backrest	25 Nm

### Setting the adjustable handlebar stem

(Easy Rider, Easy Rider Compact)

If the handle of the handlebar stem does not close properly and the handlebars are not sufficiently clamped by the stem, the adjustment bolt must be readjusted.

Follow the following instructions to properly adjust the handlebar stem:

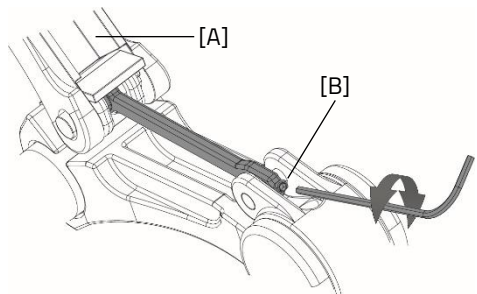

1. Open the handlebar stem bracket [A].
2. Now the adjusting screw can be set.
3. To increase the clamping force: tighten the adjusting bolt clockwise.
4. To decrease the clamping force: loosen the adjusting bolt counter clockwise.
5. Now close the handlebar stem bracket [A].



The bar must close with a resistance of 120-150 N. Otherwise, the handlebars may come loose while riding, resulting in serious injuries.

## The correct tension of the chain

The chain should not be too tight. It must be able to move. The chain should be able to be moved up and down by about half a centimetre without any effort.

## Adjusting chain tension

(Easy Rider, Easy Rider Compact)

In order to set the chains to the correct tension, it is important that the correct sequence is followed. Follow the instructions below to adjust the hub and tension wheel so that the chains have the correct tension:

1. Loosen the nuts [A] on both sides of the hub.
2. Now tighten the nuts [B] to increase the tension of the chain [C]. Adjusting the tension of this chain will affect the other chain [D].
3. When the chain has the correct tension, tighten the nuts [A].
4. Adjust the tension of the next chain [D]. Loosen the bolt [E] a few turns with an Allen key. On the other side, prevent the nut from turning with a wrench.
5. Move the tension wheel so that the chain has the correct tension as described above.
6. Then re-tighten the bolt and nuts.
7. To adjust the tension of the motor chain [F], repeat the actions from steps 2 to 4 for this chain.

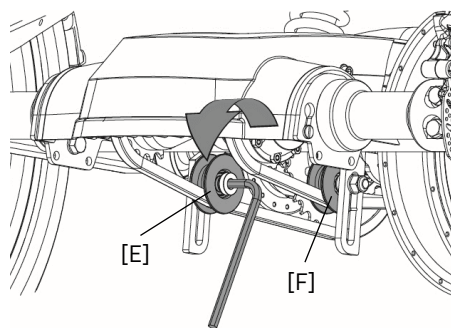
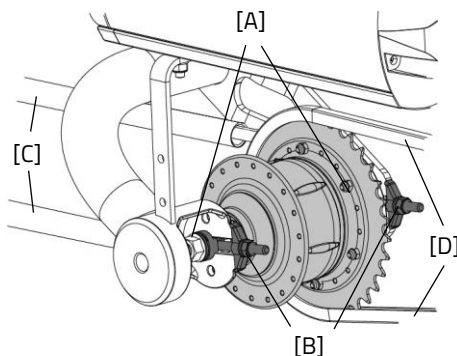

## Adjusting chain tension Easy Rider Small

In order to set the chains to the correct tension, the following actions must be taken:

1. Loosen the nut [A] a few turns. On the other side, prevent the nut from turning with a wrench.
2. Push the tensioner upwards to increase the tension on the chain.
3. When the chain has the correct tension, tighten the nut [A] again.
4. Loosen the nuts [B] on both sides of the hub a few turns.
5. Then loosen the tensioner nut [C] a few turns.
6. Now tighten the nuts [D] to increase the chain tension. When the chain has the correct tension, the nuts [B] can be tightened.
7. Now pull the tensioner down to increase the tension on the chain and then retighten the nut [C].

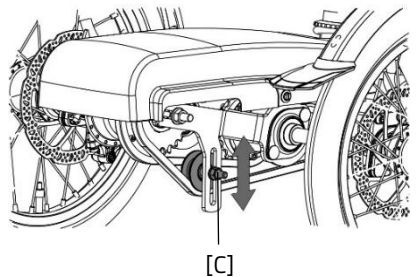
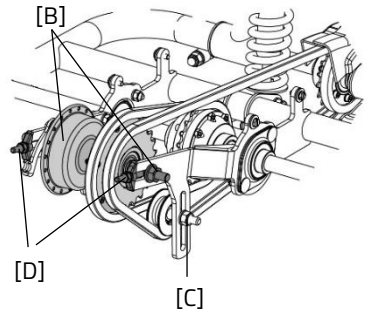
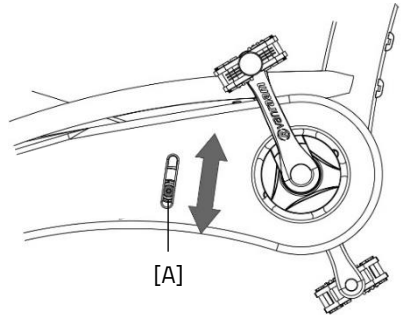

## Replacing the shock absorber Easy Rider

The Easy Rider has a suspension frame (optional choice of suspension suitable for the body weight). To replace the suspension is recommended to hang the bicycle in a hoist. Make sure the swingarm can hang freely from the rear fork.

To replace the suspension:

1. Loosen the hexagon bolt [A]. Hold a wrench on the nut, otherwise the nut will rotate.
2. Support the swingarm and loosen the bolt [A]. **Please note!** The swingarm will drop down if unsupported. Now slowly lower the swingarm.
3. Now the hexagon bolt [B] of the swingarm can be loosened.
4. The suspension can now be replaced.
5. **Please note!** The suspension must be mounted in the damper free of slack. To do this, turn the tension ring [C] in the direction shown in the picture. This can be done by turning the suspension by hand, the tension ring will then rotate.
6. Re-tighten the bolts [A, B].

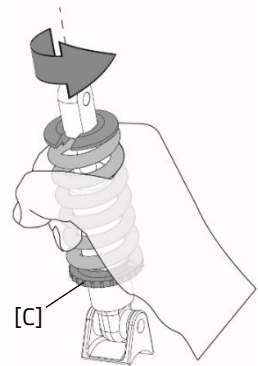
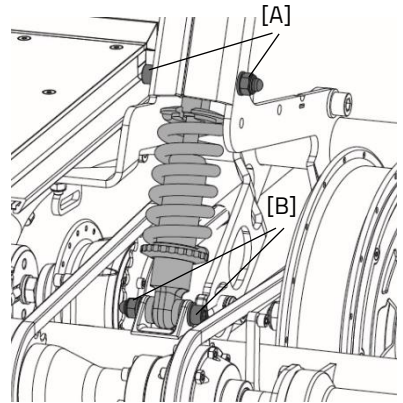

For the best handling characteristics, it is recommended to choose a suspension that fits the weight of the user.

Suspension type:	User weight:
550 lbs	< 80 kg
750 lbs	80 – 110 kg
1000 lbs	> 110 kg

## Seat suspension Easy Rider Compact

The Easy Rider Compact has a seat with a suspension spring. This spring can be pre-tensioned to make the suspension a bit stiffer.

To increase the tension of the suspension, follow these steps:

1. Grasp both the tension ring and the suspension with your hands.
2. Turn the tension ring and suspension clockwise. (Rotation direction as illustrated in the picture.)

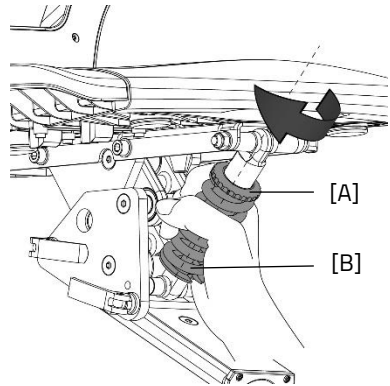



## Return point for removal

If you want to return the bike, please contact your dealer. You can also contact the local waste disposal company. He will recycle the bike according to the rules of your place of residence.

## Recycling the battery

If your battery is defective or if you are not longer using it, you must have it recycled. Please contact your dealer. They are responsible for complying with the recycling obligation. Ask them about the conditions or view the rules regarding recycling in your place of residence/country.

## Handover / sale to a new owner

If you transfer the tricycle to a new owner, it is important that you hand over all necessary technical documentation and spare keys, so that the new owner can use the bicycle safely.

Do you use the Van Raam E-Bike App and have you linked your bike and battery to the app? Make sure you disconnect the bike and battery from the app when transferring/selling. **Please note!** Your cycled routes will not be lost and you can always continue to view them in your Van Raam E-Bike App account. The next owner cannot view your cycled routes.

## Warranty

The warranty applies to all product defects for which it has been proven that the cause is a material or manufacturing defect.

We give a five-year warranty on the frame and front fork. For all accessories and other parts (with the exception of wearing parts), we apply the statutory warranty period of two years. The warranty only applies to normal use and maintenance of the bicycle, as described in this user manual.

### **Please note!**

Both the warranty and the product liability in general expire if the instructions in this user manual are not followed, if maintenance work has been carried out incorrectly or if technical changes or additions have been made to the bicycle with non-original Van Raam parts, without permission from Van Raam. The original CE-declaration on the bicycle will also lapse in the event of adjustments by third parties. The lack of a CE-declaration can lead to problems when insuring the bicycle and in the event of damage or liability.

## Frame number

You will find the frame number on the sticker. This sticker is applied to the frame, see pictures.

Example sticker:



Position sticker Easy Rider, Easy Rider Compact and Easy Rider Small:

Easy Rider



On the frame tube

Easy Rider Compact



At the back of the frame tube

Easy Rider Small



On the frame tube

## Maintenance recommendation

A Van Raam bike often is subject to extensive use and must perform in all weather conditions. By correctly maintaining the bike, the lifecycle can be extended greatly. This maintenance can be done by a Van Raam dealer. In most cases, you can do the monthly and annual inspection yourself.

### Maintenance Overview:

What	One-person bike	Multi-person bike	Duration	By whom?
1 <sup>st</sup> service moment	3 months/300 km	3 months/200 km	15 min	Dealer
2 <sup>nd</sup> Service moment	6 months/1.000 km	6 months/500 km	15-30 min	Dealer
3 <sup>rd</sup> Service moment	12 months/2.000 km	12 months/1.000 km	30-90 min	Dealer
Monthly inspection*	Every month	Every month	15 min	User
Annual inspection*	Every 12 months	Every 12 months	60 min	User

\* This is advised to extend your bike's lifecycle. You can also have this done by your dealer.

#### Monthly inspection

15 minutes

Among them:

- Check and inflate the tyres
- Check the chain tension and grease if needed
- Tighten bolts/nuts where needed
- Check all lights
- Check the brakes
- Check all rotating parts and grease if needed
- Clean the bike

#### Annual inspection

60 minutes

Among them:

- Check and touch up the paintwork
- Check the wheels for any buckling
- Check the spoke tension
- Check the steering ball joints
- Check all lights
- Check the saddle clamp
- Check the placement of all electric components (E-Bikes only)

### **1<sup>st</sup> Service moment**

15-30 minutes

Among them:

- Check tyres and inflate
- Check the spoke tension
- Check the chain tension and grease
- Tighten any bolts and nuts if needed
- Check all brake cables and brake calipers
- Check the gears
- Check and grease all rotating parts
- Check all lights
- Clean the bike

### **2<sup>nd</sup> Service moment**

30-90 minutes

Among them: All points from service moment 1, and:

- Inspection of the pedals and bottom bracket
- Grease and tighten the lock
- Grease and tighten the steering stem
- Check the steering ball joints
- Run all tests in the dealer tool (E-Bike)

### **3<sup>rd</sup> Service moment**

60-120 minutes

Among them: All points from service moment 1, 2, and:

- Inspection of the paintwork
- Inspection of the frame/front fork
- Inspection of the seat cushions
- Inspect the functioning and sound of the motor/gear hub
- check reflectors for any damage
- Check all electric components on their placement (E-Bike)
- Run all tests in the dealer tool (E-Bike)

## Service plan

### 1<sup>st</sup> Service moment

- Yes/No
- Dealer:
- Mechanic:

Date:

Remarks:

.....

.....

.....

.....

### 2<sup>nd</sup> Service moment

- Yes/No
- Dealer:
- Mechanic:

Date:

Remarks:

.....

.....

.....

.....

### 3<sup>rd</sup> Service moment

- Yes/No
- Dealer:
- Mechanic:

Date:

Remarks:

.....

.....

.....

.....

## Annual inspection

Date	Dealer	Mechanic	Remarks









## Delivery and service form

Congratulations on your Van Raam bicycle. This bicycle has been produced with the utmost care. To guarantee a high quality as much as possible, Van Raam produces the bicycles according to the ISO 9001: 2015 quality requirements. Van Raam has been certified for this by DNV GL Business Assurance B.V.

You can optimally enjoy this Van Raam bicycle, specially produced for you, if the bicycle is adjusted to your requirements and the instructions in the user manual are followed. Make sure to observe the service intervals prescribed in the operating instructions.

To be able to claim service and warranty, you must always fill in the forms at delivery and service intervals. With this form, the dealer and the end user also sign that the end user has been instructed about the operation of the bicycle, that the bicycle has been adjusted to the wishes of the end user and that the end user has received the original Van Raam manual.

### Fill in when delivering the bicycle

Van Raam bicycle type:	
Frame number:	
Key number:	
Delivered to:	
By dealer:	
Location:	
Date:	
Signature bicycle user:	Signature dealer:
Dealer stamp (if available):	