

## User manual



### Chat

Van Raam  
Guldenweg 23  
7051 HT Varsseveld, The Netherlands

☎ +31 (0)315 – 25 73 70

✉ [info@vanraam.com](mailto:info@vanraam.com)

🌐 [www.vanraam.com](http://www.vanraam.com)

Version 23.11



# Table of contents

Manufacturer contact details .....	3
Conformity Europe (CE) .....	3
Conformity UK (UKCA) .....	3
Introduction.....	4
Delivery.....	4
Indication.....	4
Intended usage .....	4
Safety measures.....	5
Adjustment of the trishaw .....	7
Before the first use.....	10
Electro system Silent .....	17
Van Raam e-bike app.....	27
Accessories.....	28
Technical specification.....	31
Maintenance and adjustments by owner.....	32
Repair and maintenance by your dealer .....	34
Adjustments by dealer .....	35
Disposal .....	36
Handover/sale to a new owner .....	36
Guarantee .....	37
Frame number.....	38
Maintenance recommendation .....	39
Service plan.....	41
Delivery and service form.....	43

## Manufacturer contact details

Van Raam

Guldenweg 23

7051 HT Varsseveld, The Netherlands

☎ +31 (0)315 – 25 73 70

✉ info@vanraam.com

🌐 www.vanraam.com

## Conformity Europe (CE)

Van Raam Reha Bikes B.V., as manufacturer, declares that the Chat, as described in this user manual, is manufactured in accordance with Regulation (EU) 2017/745, risk class 1. The Chat supplied with the Silent electrical system also complies with Directive 2006/42/EC including the applicable parts of EMC Directive 2014/30/EU and the NEN-EN 15194:2017 Bicycles - Electric supporting bicycles - EPAC Bicycles - part 4.2 Electrical requirements. The signed declaration of conformity can be found on the Van Raam website.

## Conformity UK (UKCA)

Van Raam Reha Bikes B.V. as manufacturer declares that the Chat, as described in this user manual, is manufactured in accordance with the "Essential Requirements of Medical Devices Regulation 2002" (UK MDR 2002 Class 1 Medical Devices). The Chat supplied with the Silent electrical system also complies with the "Machinery (Safety) Directive SI 2008/1597" including the applicable parts of "Electro Magnetic Compatibility Regulations SI 2016/1091" and the NEN-EN 15194:2017 Bicycles - Electric support bicycles - EPAC Bicycles - part 4.2 Electrical requirements. The Chat is provided with UKCA label according to "EU Exit Regulations 2020/1478". The signed declaration of conformity can be found on the Van Raam website.

## Introduction

This user manual provides important and necessary information about the use of your trishaw. We ask you to read this manual thoroughly before using the trishaw. Always follow the instructions as provided in this user manual and keep the manual carefully. The most current version of the user manual can be found on the product page of the bicycle on the website [www.vanraam.com](http://www.vanraam.com).



**READ CAREFULLY**

## Delivery

Your delivery should include the following:

- Trishaw with packaging
- User manual(s)
- Possible Smart-battery including card with 5-digit code (depending on options)
- Possible chargers (depending on options)
- (Spare) keys

Check the delivery immediately after receiving it. In case of damage or incomplete delivery we ask you to contact your dealer immediately. Upon delivery you should fill out the form "Form service, maintenance, modifications a warranty claims" in the back of this manual.

## Indication

The Chat is meant for cycling together with children or adults.

## Intended usage

The trishaw has been designed for normal use on a flat, solid surface (do not use the trishaw off-road). General trishaw-caution should always be observed when using the trishaw. Moreover, the safety instructions as described in this manual should be explicitly followed. Local traffic laws and regulations should also be observed.

The trishaw is suitable for cycling together, with one driver (maximum 120 kg) and the passengers (maximum combined weight of 200 kg). The driver must be physically fit and should not have any serious visual impairment or other disability that may negatively affect the operation of the bike. The bike is not made for the transportation of goods.

The manufacturer is not responsible for any damage or injury caused as a result of or during the course of any other type of use.

## Safety measures

- Ensure the trishaw is in good condition each time before using it. Check before **each** ride that the brakes are in order. Check the lighting and make sure there is enough tyre pressure. Please note, your bike tires are equipped with car-type air valves.
- We recommend always having a First Aid Kit present on the bike and having an way to call for help in case of emergencies, for example a mobile phone.
- Never leave the bike unattended with passengers on the bike.
- The use of a seatbelt by passengers is mandatory. If one of the seatbelts is defective, have it repaired at your dealer as soon as possible.
- Regularly check if the wheels, the handlebars and the saddle are properly fixed and also whether all screw joints are tight.
- Only use the trishaw on a **solid and level surface** (or: not for off-road use).
- It is not recommended to cycle on a slope steeper than 10%, this carries an increased risk.
- A trishaw is sensitive to tipping when riding across a speed bump. Therefore, it is important to always drive straight towards a speed bump.
- Make sure that wide trousers or loose hanging clothing don't get caught in the chain, spokes or pedals.
- Block the trishaw to stop it from moving when you are getting on or off the trishaw. Do this by using the parking brake and holding the trishaw.
- Always lock the trishaw when leaving it unattended.
- The trishaw is specifically designed to perform best when carrying passengers; avoid cycling without a passenger as much as possible. The trishaw will behave differently, which may lead to instability.

- While riding as a passenger, **never** place your feet underneath or beside the footrest. You may get hit by moving parts and incur bruising.
- Make sure that you do not reach a dangerous speed when driving downhill and entering tunnels. Brake in time and bike at a moderate speed.
- Please note, when pedalling the trishaw that the front has a small blind spot where you do not always have an optimal view.
- The bike is not made to transport goods, this may negatively affect steering.
- Exercise more care if the driver or any passenger is pregnant, owing to a higher risk of injury.
- Do not leave the trishaw in direct sunlight: the temperature of some parts could exceed 41°C resulting in possible burns to the skin.
- Your trishaw is equipped with the Silent electric motor system, make sure that you get used to riding with the electric support engaged. Be careful when you turn on the electric support system and make sure you don't get startled by unexpected behaviour because you turned on the electric support.

## Load

The maximum load should not be exceeded. See the information in the technical data table in the '**Technical Specifications**' section of the user manual. The permitted load refers to the total load, including the load in the baggage compartment and on the baggage carrier.

Make sure that the permitted load on the luggage is not exceeded. (**maximum** 20 kg).

People may not be transported on the rear luggage rack.

## Damaged or worn out parts

The replacement and repair of parts (frame, forks, light, brakes, drive mechanism and the handlebars) should **always** be performed by an authorised dealer. If not, the guarantee ceases to be valid and you will be personally responsible in the event of possible damage.



Specific safety parts should **always** be replaced by new parts!

## Adjustment of the trishaw

Before using the trishaw, adjust its height to the height of the rider. This is of essential importance, especially with regard to the, saddle, handlebars and seat.



*If an optimum setup with specified instructions is not possible you can contact your dealer for a suitable solution.*

The brakes are always properly adjusted and may only be adjusted during regular maintenance by your dealer.



Take care that fingers and limbs do not get trapped while adjusting the trishaw.

### Saddle Height

You can correctly set the saddle height by sitting on the bike and placing your foot on the pedal in the lowest position. Make sure your leg is stretched, yet still relaxed.

To adjust the saddle:

1. Open the quick-clamp [A].
2. Slide the saddle to the correct height.
3. Close the quick-clamp.

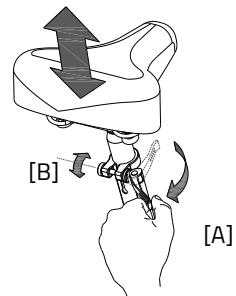
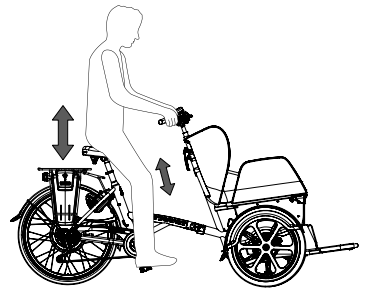

*Make sure clothing cannot get caught in the clamp!*



*If the clamp closes too easily, the clamping force is too low. In this case, open the clamp and tighten the nut [B] a bit more. If a lot of force is necessary to close the clamp, the nut should be loosened slightly.*



Don't **pull out** the seat post further than the markings. If you do so, the tube won't be inserted deep enough into the shaft, increasing the risk of breakage, which may lead to serious injuries.



## Handlebars height

The height of the handlebars greatly influences ride comfort. It determines the pressure on the hands and posture of the back. You decide the most comfortable position yourself with some practice.

To adjust the handlebar:

1. Loosen the screw with an Allen key.
2. Slide the handlebars stem to the desired height and then firmly tighten the screw.

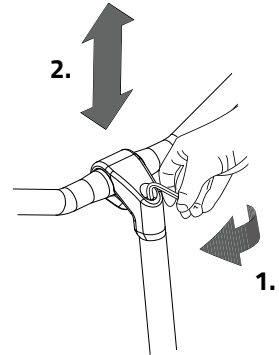

## Steering Position

You can tilt the handlebar. This affects the distance from the handlebars to the upper body. Feel free to determine what setting is most comfortable for you.

To tilt the handlebar:

1. Loosen the screw using an Allen key.
2. Place the handlebars in the desired position and firmly tighten the screw.

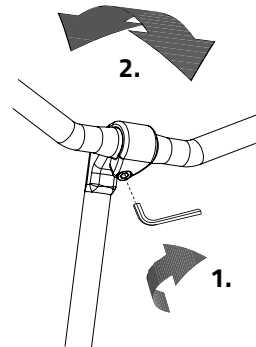



## Passenger hip belt

Use the hip belt when you go cycling. Place the belt around the body of the passenger and adjust the length of the belt for the individual.

1. Fasten the metal fittings together.
2. Adjust them by pulling the loose end of the belt.
3. To remove the belt, lift the top part of the buckle and disconnect the fittings.

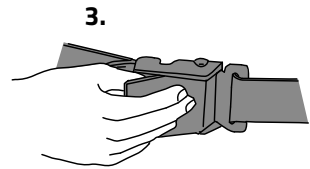
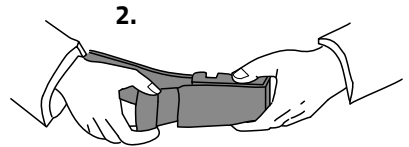
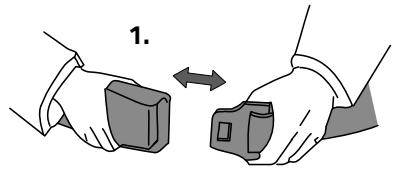

## Before the first use

### Parking brake

Always use the parking brake if you park the tricycle and leave it behind.

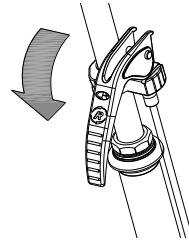

Block the tricycle with the hydro brake when passengers are getting on and off.

To operate the parking brake, squeeze the left brake [A] and secure the brake with the lever [B].

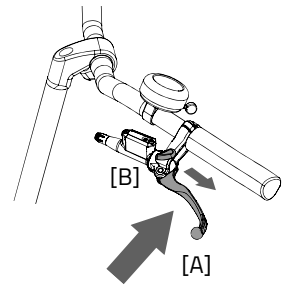

Always try to park the tricycle on a level surface. The tricycle may never be parked on a slope bigger than 6 degrees.

### Centrally operated lighting

The bike is fitted with centrally operated lighting whereby the lighting is connected to the electronic system.

The lighting automatically turns on when the electronic system is activated.

Adjust the angle of the front light so that the centre of the light beam is located approximately ten metres in front of the trishaw.

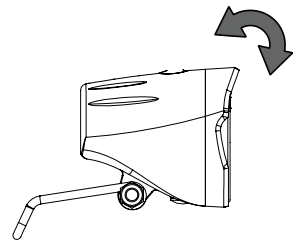

You can switch the lighting on and off manually by briefly pressing the on/off button on the display or by using the button on the lighting. If the electronic system is switched off, the lighting automatically switches off.

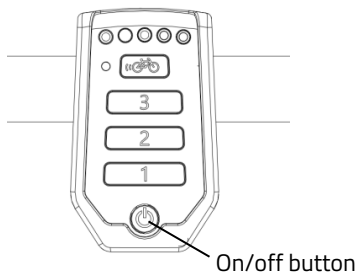

*When cycling in the dark, make sure there is always a battery present on the bike!*

When the battery is almost empty, the motor will no longer provide support while cycling. However, the switchable lighting will still work on the residual power.

## Gears

Your trishaw has eight gears. The gears can be adjusted by turning the handle.

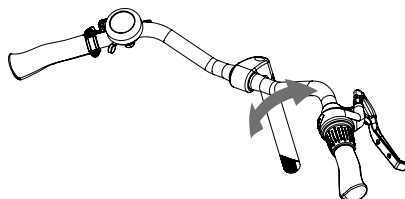

Your trishaw has an electric motor at the rear, you must **continue pedalling** when changing gears.



**Please note!** Do not shift gears and then paddle backwards. This could cause the chain to run off the sprocket.

## Footrest

For optimal accessibility when passengers are getting on and off the bike, you may lower the footrest.

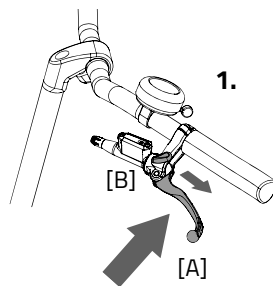

Always lower the footrest when getting your passengers on and off the bike to prevent the bike from tipping over.

To operate the footrest, follow the steps below:

1. Set the parking brake by pinching the left brake [A] and securing the brake with the handle [B].
2. Lower the footrest control pedal by pressing down on the tab marked "PUSH".
3. Remove the safety pin securing the handle.
4. Press down on the footrest control pedal with your foot and pull the handle up so the footrest unlocks. You can **slowly** lower the footrest by providing counter-pressure with your foot on the footrest control pedal when you lift your foot.

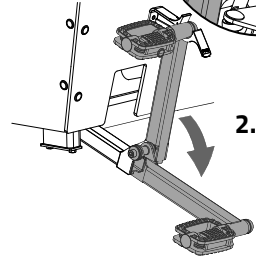
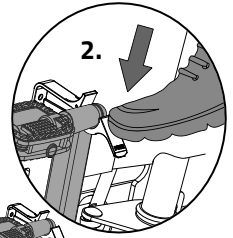

**Please note!** If the passengers are already seated, warn the passenger before unlocking the footrest.

5. Have the passengers take their place on the bike and secure the seatbelt around the passengers.



Place legs and feet inside the footrest space so limbs do not get trapped!

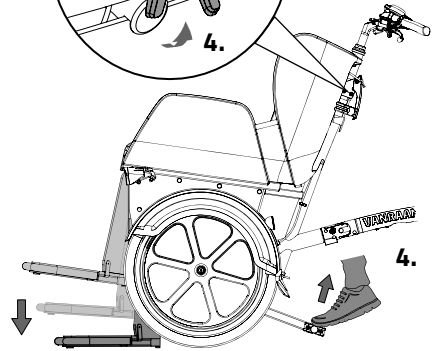
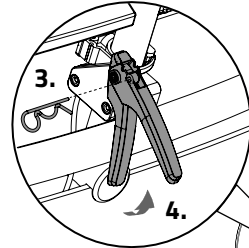

6. To lift the footrest, place your foot on the control pedal and **slowly** press the pedal down until it locks and you can hear a 'click'.



**Please note!** Warn your passengers before you lift the footrest.

"click"

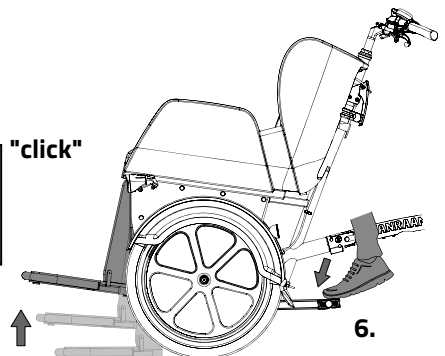

7. Place the footrest control pedal back into the brace.
8. Finally, place the safety pin back in the link in the handle.



Only use the footrest when standing still.



The footplate is only intended to support the passengers' feet. Do not load heavy objects on the footrest and don't stand on it while the footplate is raised.

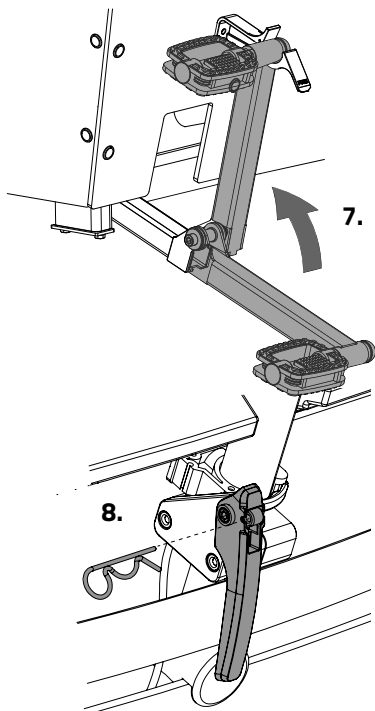

## Baggage space

On the back of the seat there is a baggage compartment [A].

At the front, beneath the seat, there is also a baggage compartment [B]. You can access this baggage compartment by lowering the footrest.

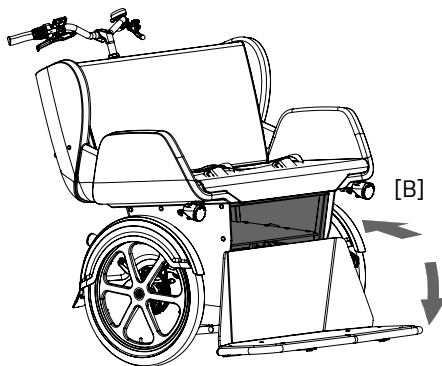
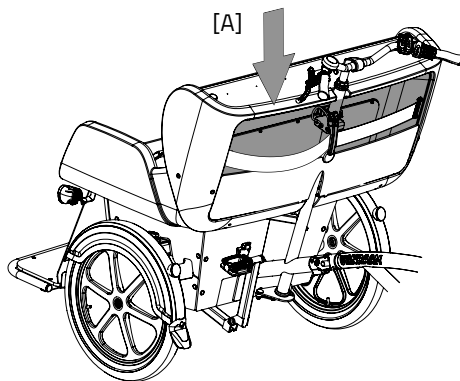

## Seat cushion

The seat cushion is water resistant. Remove the cushion from the bike when you park the bike and leave it unattended.

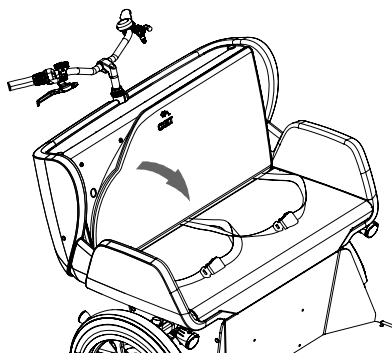

## Before every ride check:

- The brakes (including the parking brake)
- The tyre pressure
- The lighting
- That all parts are secure
- That the battery is sufficiently charged

Contact your dealer and never use your bike if you notice any irregularities.

As is the case with all mechanical parts, the trishaw is subject to wear and high loads. If a component fails, this may lead to very dangerous situations and damage or injury to the trishaw or user. Any form of cracks, scratches or change of colour in heavily loaded parts of a component is an indication that the part must be replaced.

## Points of attention while cycling

Once you've set up the bike on the basis of the rider and passenger's size you can start using the bike.



Your trishaw is a tricycle. The experience of riding a tricycle is completely different from riding a bicycle with two wheels!

Practice, in particular, with bends and braking, because a trishaw can react contrary to what you would expect. It may happen that the back wheel comes off the ground on the inside when going round a bend. To avoid this, the rider leans towards the inside of the bend with his body.

One of the brake levers (usually the right) operates the brake on the front wheel. This deserves special caution, as a forceful braking could cause the front wheel to stop suddenly and skid, which could result in a fall. The driver should be familiar with controlled braking of the front wheel!



If there is an electric motor on a bike: you must train with the acceleration function and reverse functions. Be careful that the acceleration mode or reverse mode are not unintentionally started while using the bike. For example, at traffic lights the reverse function can accidentally be activated and the trishaw reverses.



High speeds in the bends, driving on rough ground, and sharp bends can lead to the trishaw **falling over!**



The trishaw will behave differently when cycling without a passenger. Try this very carefully the first time!

### Important safety precautions for the rider

- Make sure you ride with extreme caution when first using the bike.
- While riding, keep both hands firmly on the handlebars and your feet on the pedals.
- Test the bike's behaviour at an appropriate speed on uneven surfaces. In doing so, you will learn how to respond to unexpected movement of the bike and handlebars.
- Explore how the tilting movement of the trishaw reacts to your posture. Always lean towards the inside of a bend.
- Small obstacles must be traversed at appropriate speeds.
- Obstacles higher than five centimetres (or two inches) must be avoided.
- Please note that the front has a small blind spot where you do always not have an optimal view.
- Make sure not to ride at dangerous speeds when riding downhill. Brake in time and bike at a moderate speed.



## Electro system Silent

The Silent Electric motor system is a special developed support system by Van Raam for the rehabilitation market. The system is characterized by:

1. A simplicity of operation
2. Individually adjustable support for cycling
3. Modern and efficient electronics
4. The powerful electric motors
5. High quality and safe batteries
6. Highly reliable system

The Silent system comes standard with a basic support mode individually programmed for your bike. In most cases, it gives precise and smooth cycling characteristics with a good compromise between support and radius of action.

In special cases, an individually tailor-made cycling program is necessary. You can obtain information from the dealer about the possibilities of a customised cycling program.

### Functions:

The electric system has the following functions:

- Pedal support while cycling
- Start support
- Backwards pedalling with support
- Centrally operated lighting

#### 1. On/off button

Using the on/off button, the electrical system can be switched on or off.

- Switching on: Push the button briefly.
- Switching off: Push the button for two seconds.

After the system is turned on, the electric motor is active in level 1.

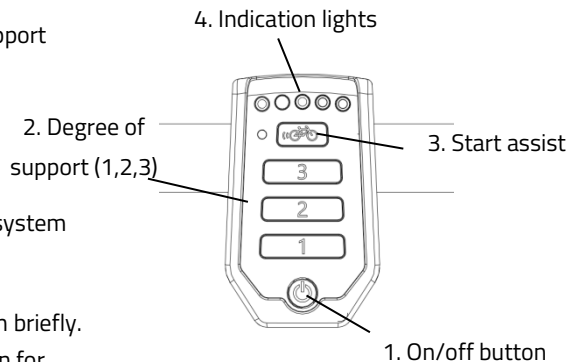



When the system is not used, it will automatically turn off after a certain time.



Always turn off the electric system before getting on and off the bike, and when you are walking while holding the bike.



Make sure that the switch under the luggage carrier is always pressed to the side where the battery is located. Note that with some models the battery switch has a middle (neutral) position as well. That means the battery is switched off.

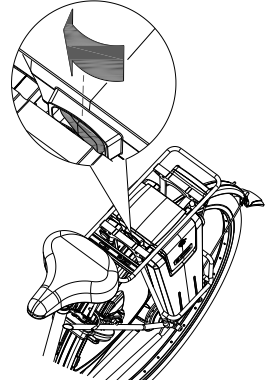

## 2. Degree of support 1, 2 and 3

The desired support can be set by using one of the support levels 1, 2 or 3.

1. Light support, maximum range.
2. Average support, average range.
3. Maximum support, low range.

You can change the level while cycling.



*The behaviour of the battery depends on a lot of different factors and is strongly influenced by: capacity and voltage of the battery, degree of support that is used, temperature, wind speed, tyre pressure, cycling speed, weight of the user, passenger's and the luggage, use of gearing etcetera.*

### 3. Start assist

The Silent electric motor has a start support. This allows the driver to pull-away without pedalling up to a speed of 6 km/h over 6 seconds. To accelerate, press the start assist button and keep it pressed down. The function will only activate again, when the support button has been pressed down again. If you peddle normally, the function works for up to 6 seconds, each time the button is pressed, up to maximum speed of the trishaw (20 km/h).

The start assist is used for:

- Extra support when starting.
- Extra support for cycling uphill.



*When cycling a steep climb, you can use support in level 3 and push the start assist repeatedly for 6 seconds to achieve maximum support.*

### 4. Indication lights

The level of charge in the battery is given by five LED lights: four of these are green, the one on the left can show either green or red, if charge is low.



The battery is fully charged. When in use, the number of green LED lights on the battery will decrease.



The battery is 50% charged when two green LED lights are on.



The battery is almost empty if only the last red LED light is on. The battery needs to be recharged or replaced by a (new) fully charged battery.



When the last red LED light flashes, the battery is empty and the motor will no longer support while cycling. The integrated lighting continues to work.

The battery is equipped with a button and indicator that makes it possible to check the charge by briefly pressing the button [A]. The status of the battery is shown with five green indicator LEDs, of which the left most one can blink. That means the battery is nearly empty. During charging, the battery displays the progress of the charging.

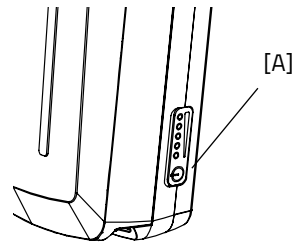

## Reverse mode

The reverse mode is activated by pedalling backwards from a standing position. Within a few seconds the motor is activated and the trishaw cycles at a speed of about 2 km/h backwards (when you start to pedal backwards).



Do not be startled by an unexpected reaction from the electrical system. If you e.g. wait for the traffic light and you play with the pedals by moving them backwards the reverse mode is activated and the trishaw cycles backwards.

## Centrally Operated Lighting

The bike is equipped with centrally operated lighting, with the lighting automatically turning on when the electric system is activated. Further instructions can be found in the chapter '**Before the first use**'.

## Other functions

The smart display has an automatic dimming function. With an inbuilt light sensor the lights of the display will automatically creating less distraction for the cyclist in darker or more shadowy conditions.

## Charging the Battery

For the best performance and to prolong the life of the battery, we recommend that you charge the battery at home at room temperature.



Only use the charger if the temperature of the environment is between 0 and 35 degrees centigrade.

To charge the battery:

1. Unlock the battery by turning the key a quarter.
2. Pull the handle forward.
3. Take the battery pack from the holder.
4. Take the battery pack inside. **First** plug the charger into the socket. The green LED will light up. The charger is now on standby.
5. **Then** insert the charging connector of the charger into the charging point of the battery. The red LED will light up. The charger is now charging.



**Please note!** If the battery is not connected properly, the green LED will light up (standby mode). If the connection is poor, unplug the plug from the socket and clean the charger's connector with a dry cloth.

6. Depending on the battery level, the charging time is about 2,5 hours with a 13,6 Ah/36 V battery.
7. Once the battery is fully charged, the green LED will be solid. Now **first** remove the charging connector of the charger from the connector of the battery.

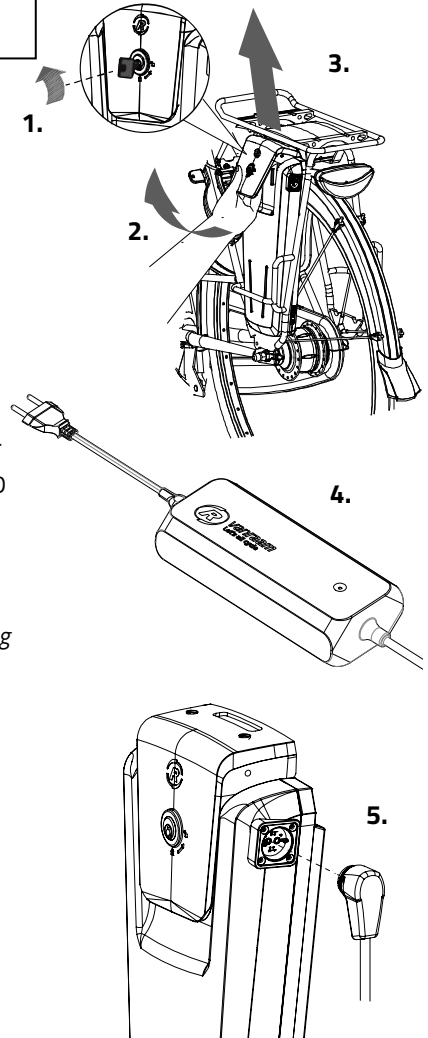

8. **Then** unplug the charger from the socket.
9. Put the battery back in the holder of the cycle. Slide it behind bar [A] and press it firmly on strip [B].
10. Pull the handle backwards and push the top of the battery to connect as shown in the drawing and close the lock.
11. Push the handle forward and close the lock.

It is also possible to charge the battery while it is still in the holder.



Do not wait until the battery is completely empty to charge it. It is better to recharge the battery interim.

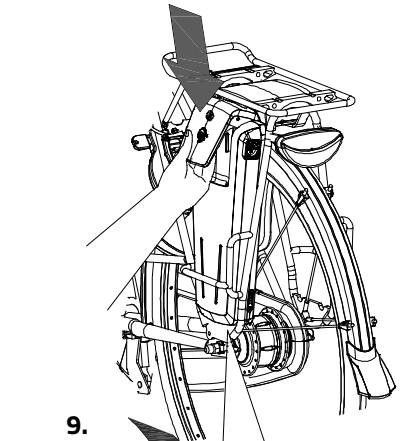

9.

[A]

[B]

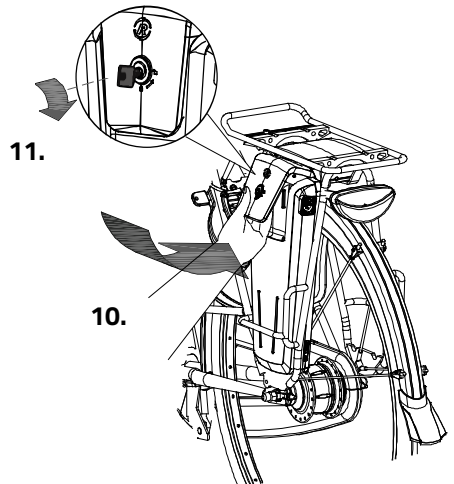

11.

10.

Charger:

LED indication	Status
Green	Standby
Red	Charging
Green	Battery full
Red, blinking	Safety: Polarity inversion; Short; Over temperature; Over power; Over voltage

### Backup battery (optional)

The bike can be supplied with a second battery.

To activate the second battery (when the first battery is empty), turn the switch under the luggage carrier to the side of the second battery.

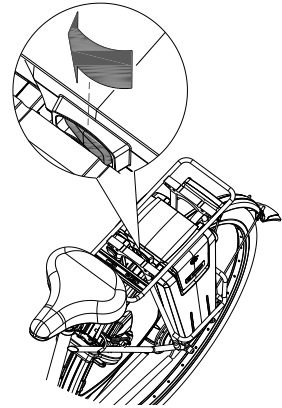

### Battery Deep Sleep Mode

When the battery is nearly empty and has not been used for a week, the battery will enter deep sleep mode. In this mode the battery uses as little power as possible, to increase the lifespan of the battery.

When the battery is in deep sleep mode, it cannot be used. By pressing the button on the battery, the battery will be woken up from deep sleep mode, and it can be used again. It is recommended to first charge the battery before using it in that scenario.

## Charging and maintenance tips for the battery

- Never leave the bike with an empty battery! We advise you charge the battery as soon as possible before it's totally empty.
- The best storage-charge of the battery is when three to five LED lights are lit.
- Check the battery every month in the winter. If fewer than three LED lights are lit, recharge the battery.
- Preferably store and use the battery in environments of 5 to 20 degrees Celsius. Avoid higher or lower temperatures.
- Do not charge the battery in sunlight and make sure that the battery is not charged at a temperature of less than 5 degrees Celsius.
- Only use the charger indoors and in non-humid environments, the charger should *not* get wet.
- Only use the Van Raam supplied battery.
- Only charge the battery with the supplied charger!
- The battery housing and charger housing may never be opened! When there is a problem, contact your dealer.
- The Van Raam battery may not be revised due to serious safety risks and the incorrect functioning of the electric system as a whole.
- Don't drop the battery, this can cause external and internal damage.
- If your bicycle has a fault, the battery should be disconnected from the bicycle.



*Keep in mind that your bike provides less support when it's cold (0°C and less) and the battery will discharge faster. Charging also takes more time at lower temperatures.*



*Every battery discharges automatically over time. This process is called self-discharge. A battery that is empty and not charged, will self-discharge and will be deep discharged. The battery can be permanently damaged during this process. In case of deep discharge, the warranty will be void.*



*Please note that any battery will wear over time. The wearing process of the battery is inevitable and depends on several factors, such as usage, number of charge cycles and the ambient temperature. Even if the battery is not used, its capacity will decrease. A worn battery can still be used, but please bear in mind that its charge level may decrease.*



## Possible malfunctions

- The system does not turn on:
  1. Make sure that the battery is properly attached.
  2. Check if the switch under the luggage carrier is pressed towards the side of the battery.
  3. Check the status of the battery. If it is empty, recharge the battery.
  4. If the above action does not help, contact your dealer.
- If the battery indicator LED lights on the display are flashing:

The motor may be overheated by continuous high load. For protection, the system will reduce the support.

  1. The system is in temperature-protection. You can continue cycling with reduced support.
  2. After cooling down, the normal support and indication will restore automatically.
- If the support LED lights on the display are flashing:

This indicates motor failure. You will need to contact your dealer.
- If a red LED light on the charger starts flashing, remove the plug from the mains outlet and do not longer use the charger. In this case, contact your dealer.

## Charger Safety Measures:

- Only charge Van Raam Li-Ion batteries with the included charger. Only connect the charger to a suitable power point (220-240 Volt AC 50-60 Hz). If the charger is not being used, unplug it from the socket and take the plug out of the battery.
- The charger may only be used by people who have read the information in this user manual and are familiar with the proper use of the charger. Keep the charger out of reach of children; do not let them play with it.
- The charger has been designed for use in a dust-free, dry, and ventilated environment. Do not expose the charger to water, heat sources, and direct sunlight. Keep the charger clean and dry.
- Do not charge batteries that feel hot to the touch. The battery may not be hotter than room temperature for charging. Stop charging if the battery becomes abnormally hot ( $>40^{\circ}\text{C}$ ).

**Please note!** The charger may become hot during charging  $> 50^{\circ}\text{C}$ . First carefully feel if it is safe to touch the charger. This temperature can cause sensitivity or startle if it comes into contact with the skin.

- Do not use the charger if it is visibly damaged or modified. Do not repair the charger! Please contact Van Raam. Never open the charger yourself!
- While charging, please monitor the charger and the battery. Once the battery is full, remove the plug from the socket and the plug out of the battery.

## Van Raam e-bike app

The Van Raam bicycle app is a free smartphone app that you can use while cycling on your electric Van Raam bicycle.

### What can you do with the Van Raam e-bike app?

- App can be used as a luxury bicycle computer
- Change bike settings
- Send SOS messages with GPS location to a number of your choice
- View cycled routes
- View information about the bike

### How does the Van Raam e-bike app work?

With the Van Raam e-bike app, a connection can be made with the display via Bluetooth connection. As soon as the display is ready to connect to the smartphone, the on/off button will briefly turn blue.

This app can be used as a luxury bicycle computer for Van Raam bicycles with pedal assistance and also contains many other extra functionalities. The dashboard on the app shows the current speed, total distance, trip meter, battery capacity and power consumption during the bike ride. For more cycling data, there is a details screen including average speed, maximum speed, total distance, power, battery voltage, pedaling power and pedaling frequency.

The Van Raam e-bike app can be downloaded free of charge from the **Google Play Store** or **Apple App Store**.

For more information about the Van Raam e-bike app, you can visit the Van Raam website: [www.vanraam.com](http://www.vanraam.com).



## Accessories

Depending on your order, you can use the accessories described below. Additional accessories are available from your dealer.

### Canopy

The canopy offers passengers protection from sun, rain, and wind. The material is water resistant.



**Please note!** Make sure the canopy is tensioned correctly before you start cycling.



Make sure fingers and other limbs do not get trapped when securing the canopy.



Be aware that as a driver, your view is reduced when the canopy is unfolded.

The canopy can be easily folded and stored by following the steps below:

1. Relax the four belts by opening the buckles [A]. Then remove the rings [B] from the cams.
2. Zip open the back flap of the canopy.
3. Hold the front of the canopy, so it cannot tip forwards and undo the pushbuttons on the back.

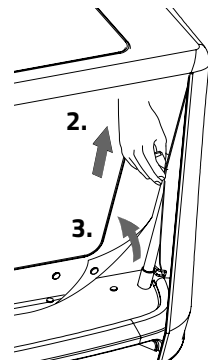
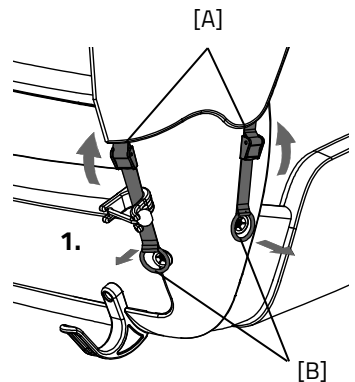
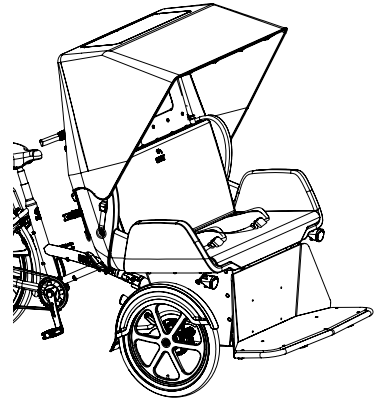

4. Place the side flaps on top of the canopy and fold the three canopy braces towards each other.

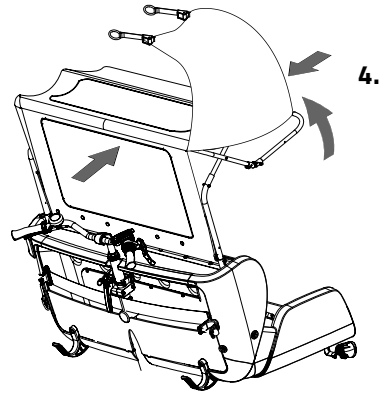

5. Fold the back flap around the poles to create a small package and secure it with the elastic band.

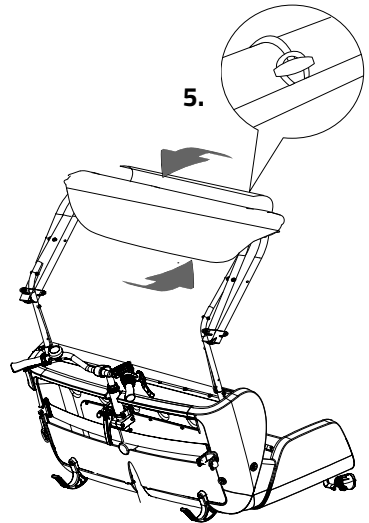

6. Remove the top part of the canopy construction and place this in the suspension hooks on the back of the seat.

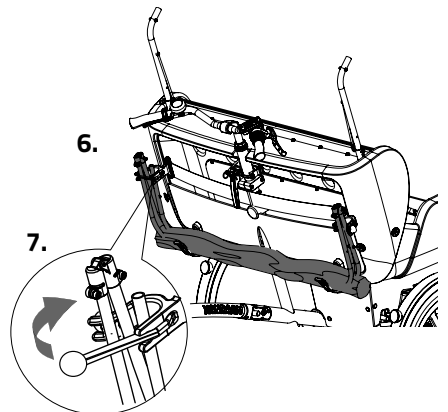

7. Move the elastic around the poles on both sides.

8. Then remove the two retractable poles from the seat by opening the securing pin and removing them.
9. Place the poles in the baggage compartment on the back of the seat.

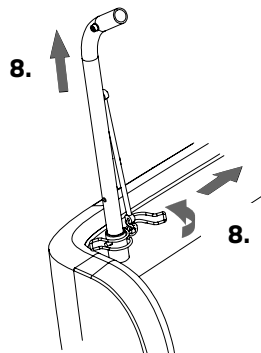

To attach the canopy again, follow the steps in the opposite direction.



If the canopy is wet from rain, let it dry first before folding and storing it.



We do not recommend cycling with the canopy above wind speed four!



**Only** use the suspension hooks for hanging the canopy, do not suspend any other items from this.

The canopy is adjustable to two settings. Set the canopy to the length of your passengers.

For the tallest setting [A], set the securing pin to the bottom opening, as shown. For the lowest setting [B] move the curved poles down and set the securing pin to the top opening.

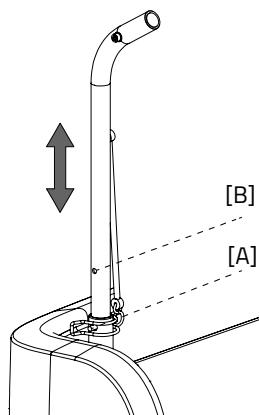

*First set the canopy to the desired height and then pull the canopy to tension.*

## Technical specification

Length (cm)	232
Width (cm)	111
Height (cm)	117
Mounting Height (cm)	45
Inseam Size (cm)	80-95
Seat width passengers (cm)	100
Front Wheel	20"
Rear Wheel	26"
Weight (kg)	approx 97
Max. Load Rear Carrier (kg)	20
Max. load of baggage compartment front (kg)	5
Max. load of baggage compartment back (kg)	5
Max. Weight Rider (kg)	120
Max. Weight Passenger (kg)	200
Brakes, front	Disc Brakes Hydro
Rear Brakes	Cantilever / Rim Brakes

## Maintenance and adjustments by owner

Below are some instructions for maintenance and adjustments that you can perform on a regular basis. This ensures an optimum condition of your bike.

### Cleaning

The frame of the trishaw can be cleaned with a damp cloth. For dirty spots it is recommended to use a mild detergent.

The wheels can be cleaned with a damp brush with plastic bristles (not a wire brush!). The saddle, handlebars and seat can be cleaned with mild soap and water.



Never use a high pressure or steam cleaner!

### Cleaning the upholstery

The upholstery of the seat is removable and may be cleaned. To do so, remove the upholstery from the cushions. You can wash the upholstery in the washing machine up to 40°C.

### Cleaning the cover

The cover can be cleaned with a wet cloth. You can use a mild cleaning agent for dirty spots. If the cover is wet, leave it to dry before folding and storing it!



## The right lubricant

The chain should be cleaned and maintained regularly (approx. once every three months). Only use special chain grease or Teflon spray. This is the only way to ensure that the chain moves smoothly, remains water-repellent and does not rust.

1. Clean the chain with a cloth.
2. Treat the chain with grease or spray.
3. Remove all abundant lubricants with a rag.

**Never** treat any of the other parts with lubricant.

## The correct tire pressure

Make sure there is enough air in the tires before every trip. Please note, your bike is fitted with car-type valves. The correct tire pressure is listed on the side of each tire.

## Inspection of the trishaw

It is necessary to have the bike inspected by a dealer at least once a year. This in order to extend your warranty claim. Please use the 'Service, Maintenance and Modifications Form' at the back of this manual when doing so. The first maintenance will be performed after the first 200 kilometres or two months.

In case of failure or defects, **immediately** bring the trishaw to the dealer for repair.

The replacement of safety-related components (i.e. frame, brakes, lights, handlebars, front fork and drive) must be done by your dealer.

If you choose to replace components by yourself, you will be liable for any damage or injury caused by improperly installed components.

Only use **original** Van Raam spare parts. You can purchase these from your dealer. Upon request, the dealer will provide the necessary information for repair and maintenance.

## Repair and maintenance by your dealer

During the maintenance session, check the brakes, wheels, lights, chain tension and spokes. Also check the tread depth of the tyres. This must be at least one millimetre. Worn tyres or defective parts must be replaced. Also check the operation of the parking brake. When the parking brake is active, the trishaw with rider may not move.

Finally, the front suspension must be checked. First check whether the bolts are secure. Subsequently check whether the spring does not allow any vertical play. If this is the case, it is necessary to take a closer look at this component.

### Inspection of the rims

Due to the interplay between both the brake and rims, both the condition of the brake lining and rims is important. For this reason, the rims must be regularly inspected (e.g. when pumping the tyre). The presence of fine cracks in the rim at the spoke nipples or deformation of the rim during elevated air pressure in the tyre, indicate greater wear and tear. In that case the rim must be replaced. If not, this may negatively impact the operation of the brakes or may even cause a break in the rim with all sorts of dangerous consequences.

Repairs, maintenance and modifications may only be performed with original Van Raam parts.

## Adjustments by dealer

### Setting the steering

In order to realise optimal steering behaviour and minimal tyre wear, the steering must be set correctly.

1. Loosen the left and right nuts of the steering shaft [A].

**Please note!** This is a nut with a left wire and a nut with a right wire.

2. Subsequently turn the steering shaft to adjust the tracking of the wheels. The wheels must be set parallel.
3. Tighten the nuts of the steering shaft again.

4. Loosen the two nuts of the steering shaft [B].

**Please note!** This is a nut with a left wire and a nut with a right wire.

5. Make sure the steering stop is in the middle of the steering plate [C].
6. Subsequently move the steering shaft to ensure that the wheels face straight ahead when the steering stop is in the middle of the steering plate.
7. Tighten the nuts of the steering shaft again.

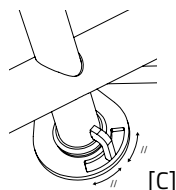
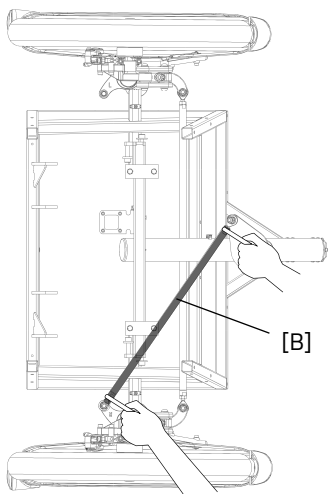
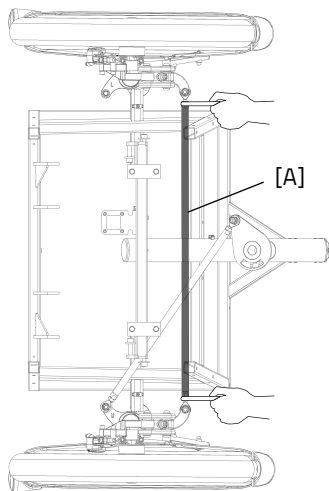

8. Finally point the handlebar straight ahead. Make sure the wheels also face straight ahead at that moment.
9. Check whether the trishaw easily drives straight ahead on the tyres, without resistance and friction.

## **Disposal**

If you want to dispose your tricycle, contact your dealer. You can also contact the local waste disposal company. They will dispose the tricycle according to the regulations of your town.

## **Recycling the Battery**

If your battery is defective or if you are no longer using it, you must have it recycled. Please contact your dealer. They are responsible for complying with the recycling obligation. Ask them about the conditions or view the rules regarding recycling in your place of residence/country.

## **Handover/sale to a new owner**

When you hand over your trishaw to a new owner it is important that you also hand over all necessary technical documentation and spare keys, so that the new owner can use the trishaw safely.

## Guarantee

The guarantee is valid for all faults in the product, which are proven to be caused by material or manufacturing error.

We give a guarantee of five years on the frame and the front fork. For all accessories and other parts (except wear parts) we provide a two year guarantee, as legally regulated. The guarantee only applies for normal use and maintenance of the trishaw, as described in this manual.

### **Beware!**

The guarantee as well as the product liability in general expires if the instructions stated in this manual are not followed. This is also the case if unauthorized maintenance is carried out or if technical changes or additions are made with non-original Van Raam parts without permission of Van Raam. The original CE certification will become nul-and-void if modifications are done by third parties. The absence of the certification can lead to problems in insuring your bike, and for any loss or incurred.

## Frame number

The frame number is printed on the sticker. This sticker is located on the frame, see the image below.

Example sticker:



Position of sticker:



behind the seat tube

## Maintenance recommendation

A Van Raam bike often is subject to extensive use and must perform in all weather conditions. By correctly maintaining the bike, the lifecycle can be extended greatly. This maintenance can be done by a Van Raam dealer. In most cases, you can do the monthly and annual inspection yourself.

### Maintenance Overview:

What	One-person bike	Multi-person bike	Duration	By whom?
1 <sup>st</sup> service moment	3 months/300 km	3 months/200 km	15 min	Dealer
2 <sup>nd</sup> Service moment	6 months/1.000 km	6 months/500 km	15-30 min	Dealer
3 <sup>rd</sup> Service moment	12 months/2.000 km	12 months/1.000 km	30-90 min	Dealer
Monthly inspection*	Every month	Every month	15 min	User
Annual inspection*	Every 12 months	Every 12 months	60 min	User

\* This is advised to extend your bike's lifecycle. You can also have this done by your dealer.

#### Monthly inspection

15 minutes

Among them:

- Check and inflate the tyres
- Check the chain tension and grease if needed
- Tighten bolts/nuts where needed
- Check all lights
- Check the brakes
- Check all rotating parts and grease if needed
- Clean the bike

#### Annual inspection

60 minutes

Among them:

- Check and touch up the paintwork
- Check the wheels for any buckling
- Check the spoke tension
- Check the steering ball joints
- Check all lights
- Check the saddle clamp
- Check the placement of all electric components (E-Bikes only)

### **1<sup>st</sup> Service moment**

15-30 minutes

Among them:

- Check tyres and inflate
- Check the spoke tension
- Check the chain tension and grease
- Tighten any bolts and nuts if needed
- Check all brake cables and brake calipers
- Check the gears
- Check and grease all rotating parts
- Check all lights
- Clean the bike

### **2<sup>nd</sup> Service moment**

30-90 minutes

Among them: All points from service moment 1, and:

- Inspection of the pedals and bottom bracket
- Grease and tighten the lock
- Grease and tighten the steering stem
- Check the steering ball joints
- Run all tests in the dealer tool (E-Bike)

### **3<sup>rd</sup> Service moment**

60-120 minutes

Among them: All points from service moment 1, 2, and:

- Inspection of the paintwork
- Inspection of the frame/front fork
- Inspection of the seat cushions
- Inspect the functioning and sound of the motor/gear hub
- check reflectors for any damage
- Check all electric components on their placement (E-Bike)
- Run all tests in the dealer tool (E-Bike)



## Service plan

### 1<sup>st</sup> Service moment

- Yes/No
- Dealer:
- Mechanic:

Date:

Remarks:

.....

.....

.....

.....

### 2<sup>nd</sup> Service moment

- Yes/No
- Dealer:
- Mechanic:

Date:

Remarks:

.....

.....

.....

.....

### 3<sup>rd</sup> Service moment

- Yes/No
- Dealer:
- Mechanic:

Date:

Remarks:

.....

.....

.....

.....

## Annual inspection

Date	Dealer	Mechanic	Remarks

## Delivery and service form

Congratulations on your purchase of your Van Raam trishaw. This bike is produced with utmost care. To guarantee the quality as much as possible Van Raam produces the cycles according to the ISO 9001:2015 quality standards. Van Raam has been certified by DNV GL Business Assurance B.V.

You will especially enjoy your Van Raam bike when the bike is adjusted to your specifications and when the instructions in the user manual are followed. Pay special attention on the service intervals who specified in the manual of the bike.

To claim warranty and service you should always fill out this form, at least at delivery and service. This signed form declares that the end user had an instruction on the operation of the trishaw, that the trishaw is adjusted to the specifications of the end user and that the user manual is received.

### Fill out when the trishaw is delivered

Type Van Raam trishaw:	
Frame number:	
Key number:	
Delivered to:	
By dealer:	
Place:	
Date:	
Signature user bike:	Signature dealer:
When available, stamp dealer:	