



User manual



City walking support

Van Raam
Guldenweg 23
7051 HT Varsseveld, The Netherlands

☎ +31 (0)315 – 25 73 70

✉ info@vanraam.com

🌐 www.vanraam.com



Version 22.03

Table of contents

Manufacturer contact details	2
Conformity.....	3
Introduction.....	3
Delivery.....	3
Intended usage	3
Safety measures.....	4
Adjustment of the walking support	4
Technical specifications	7
Maintenance and adjustments by owner.....	7
Disposal	8
Handover.....	8
Guarantee	9
Frame number.....	10
Maintenance recommendation	11
Service plan.....	13
Delivery and service form Delivery and service form	15

Manufacturer contact details

Van Raam
Guldenweg 23
7051 HT Varsseveld, The Netherlands

 +31 (0)315 – 25 73 70

 info@vanraam.com

 www.vanraam.com

Conformity

Van Raam declares as manufacturer that the walking support bicycle has been produced in accordance with the Medical Devices Regulation (EU) 2017/745, risk class 1. All products have been produced in accordance with the 2006/42/EG guidelines. The signed declaration of conformity can be found on the Van Raam website.

Introduction

This user manual provides important and necessary information about the use of your walking support. We ask you to read this manual thoroughly before using the walking support. Always follow the instructions as provided in this user manual and keep the manual carefully. The most current version of the user manual can be found on the product page of the bicycle on the website www.vanraam.com.



READ CAREFULLY

Delivery

Your delivery should include the following:

- Walking support with packaging
- User manual(s)

Check the delivery immediately after receiving it. In case of damage or incomplete delivery we ask you to contact your dealer immediately. Upon delivery you should fill out the form "Form service, maintenance, modifications a warranty claims" in the back of this manual.

Intended usage

The walking support is intended for people who have difficulties walking, cannot stand for a long period of time, but still want to be able to travel long distances. The bike is designed for normal use on level and solid ground.

Safety measures

Check every time before you go for a ride:

- the brakes;
- the tire pressure;
- that all parts are fitted properly.

Load

The maximum load should not be exceeded. See the information in the technical data table in the **'Technical Specifications'** section of the user manual.

Damaged or worn out parts

The replacement and repair of parts (frame, forks, brakes and the handlebars) should **always** be performed by an authorized dealer. If not, the guarantee ceases to be valid and you will be personally responsible in the event of possible damage.



Specific safety parts should **always** be replaced by new parts!

Adjustment of the walking support

Before using the walking support, adjust its height to the height of the rider. This is of essential importance, especially with regard to the saddle and the handlebars.

The brakes are always properly adjusted and may only be adjusted during regular maintenance by your dealer.



Take care that fingers and limbs do not get trapped while adjusting the Walking support.

Saddle height

When the person is sitting on the walking support and can put both feet on the floor, the saddle height is correct. Adjust the saddle height in such a way that the leg is stretched but relaxed in that position.

To adjust the saddle:

1. Open the quick clamp a few turns.
2. Adjust the saddle to the correct height.
3. Close the quick clamp.

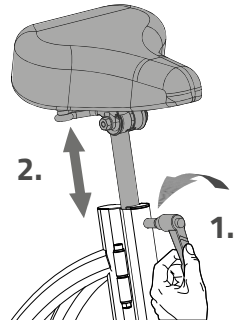

Handlebars height

The height of the handlebars greatly influences ride comfort. It determines the pressure on the hands and posture of the back. You decide the most comfortable position yourself in practice.

To adjust the handlebar:

1. Loosen the screw with an Allen key.
2. Slide the handlebars stem to the desired height and then firmly tighten the screw.

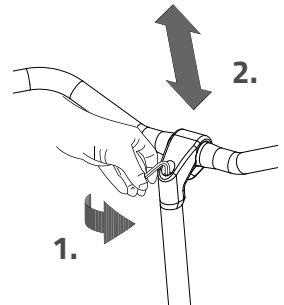

Do not **slide the** handlebars stem further than the markings. If you do so, the tube won't be inserted deep enough into the shaft, increasing the risk of breakage, which may lead to serious injuries.



Steering Position

You can tilt the handlebar. This affects the distance from the handlebars to the upper body. Feel free to determine what setting is most comfortable for you.

To tilt the handlebar:

1. Loosen the screw using an Allen key.
2. Place the handlebars in the desired position and firmly tighten the screw.

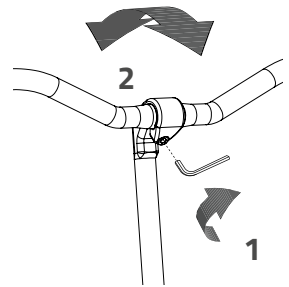

Fold the walking support

1. Open the lock with the key.
2. Open the catch and fold the walking support.

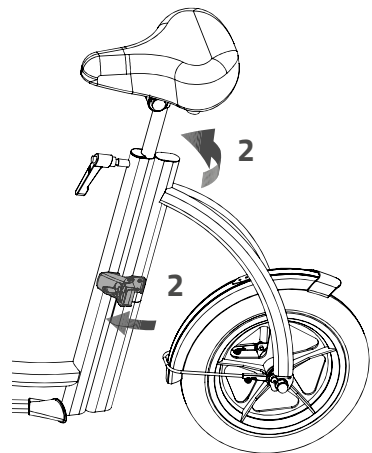
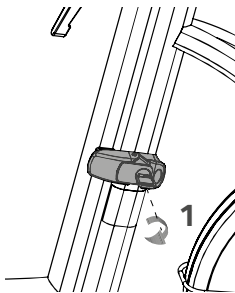

Technical specifications

Length (cm)	113
Width (cm)	55
Height (cm)	70 – 96 (customizable)
Front wheel	12,5"
Back wheel	12,5"
Weight (kg)	about 9
Max. user weight (kg)	100 ¹ , 150
Brakes, front	Cantilever brakes

¹ Standard

Maintenance and adjustments by owner

Below are some instructions for maintenance and adjustments that you can perform on a regular basis. This ensures an optimum condition of your walking support.

Cleaning

The frame of the walking support can be cleaned with a damp cloth. For dirty spots it is recommended to use a mild detergent.

The wheels can be cleaned with a damp brush with plastic bristles (not a wire brush!). The saddle, handlebars can be cleaned with mild soap and water.



Never use a high pressure or steam cleaner!

Inspection of the walking support

It is necessary to have the walking support inspected by a dealer at least once a year. This in order to extend your warranty claim. Please use the 'Service, Maintenance and Modifications Form' at the back of this manual when doing so. The first maintenance will be performed after the first 200 kilometers or two months.

The replacement of safety-related components (i.e. frame, brakes, handlebars and front fork) must be done by your dealer.

If you choose to replace components by yourself, you will be liable for any damage or injury caused by improperly installed components.

Only use **original** Van Raam spare parts. You can purchase these from your dealer. Upon request, the dealer will provide the necessary information for repair and maintenance.

Maintenance schedule (to be executed by a dealer)

Interval	Checkpoints
After 200 km, or after 2 months	The brake
Every 12 months	The whole bike
After a fall, a collision or an accident	The whole bike

Disposal

If you want to dispose your walking support, contact your dealer. You can also contact the local waste disposal company. They will dispose the walking support according to the regulations of your town.

Handover

When you hand over your walking support to a new owner it is important that you also hand over all necessary technical documentation, so that the new owner can use the walking support safely.

Guarantee

The guarantee is valid for all faults in the product, which are proven to be caused by material or manufacturing error.

We give a guarantee of five years on the frame and the front fork. For all accessories and other parts (except wear parts) we provide a two year guarantee, as legally regulated. The guarantee only applies for normal use and maintenance of the walking support, as described in this manual.

Beware!

The guarantee as well as the product liability in general expires if the instructions stated in this manual are not followed. This is also the case if unauthorized maintenance is carried out or if technical changes or additions are made with non-original Van Raam parts without permission of Van Raam. The original CE certification will become nul-and-void if modifications are done by third parties. The absence of the certification can lead to problems in insuring your bike, and for any loss or incurred.

Frame number

The frame number is printed on the sticker. This sticker is located on the frame, see the image below.

Example sticker:



Position of sticker:

Backside of the frame



Maintenance recommendation

A Van Raam bike often is subject to extensive use and must perform in all weather conditions. By correctly maintaining the bike, the lifecycle can be extended greatly. This maintenance can be done by a Van Raam dealer. In most cases, you can do the monthly and annual inspection yourself.

Maintenance Overview:

What	One-person bike	Multi-person bike	Duration	By whom?
1 st service moment	3 months/300 km	3 months/200 km	15 min	Dealer
2 nd Service moment	6 months/1.000 km	6 months/500 km	15-30 min	Dealer
3 rd Service moment	12 months/2.000 km	12 months/1.000 km	30-90 min	Dealer
Monthly inspection*	Every month	Every month	15 min	User
Annual inspection*	Every 12 months	Every 12 months	60 min	User

* This is advised to extend your bike's lifecycle. You can also have this done by your dealer.

Monthly inspection	Annual inspection
15 minutes Among them: <ul style="list-style-type: none">• Check and inflate the tyres• Check the chain tension and grease if needed• Tighten bolts/nuts where needed• Check all lights• Check the brakes• Check all rotating parts and grease if needed• Clean the bike	60 minutes Among them: <ul style="list-style-type: none">• Check and touch up the paintwork• Check the wheels for any buckling• Check the spoke tension• Check the steering ball joints• Check all lights• Check the saddle clamp• Check the placement of all electric components (E-Bikes only)

1st Service moment

15-30 minutes

Among them:

- Check tyres and inflate
- Check the spoke tension
- Check the chain tension and grease
- Tighten any bolts and nuts if needed
- Check all brake cables and brake calipers
- Check the gears
- Check and grease all rotating parts
- Check all lights
- Clean the bike

2nd Service moment

30-90 minutes

Among them: All points from service moment 1, and:

- Inspection of the pedals and bottom bracket
- Grease and tighten the lock
- Grease and tighten the steering stem
- Check the steering ball joints
- Run all tests in the dealer tool (E-Bike)

3rd Service moment

60-120 minutes

Among them: All points from service moment 1, 2, and:

- Inspection of the paintwork
- Inspection of the frame/front fork
- Inspection of the seat cushions
- Inspect the functioning and sound of the motor/gear hub
- check reflectors for any damage
- Check all electric components on their placement (E-Bike)
- Run all tests in the dealer tool (E-Bike)

Service plan

1st Service moment

- Yes/No
- Dealer:
- Mechanic:

Date:

Remarks:

.....

.....

.....

.....

2nd Service moment

- Yes/No
- Dealer:
- Mechanic:

Date:

Remarks:

.....

.....

.....

.....

3rd Service moment

- Yes/No
- Dealer:
- Mechanic:

Date:

Remarks:

.....

.....

.....

.....

Annual inspection

Date	Dealer	Mechanic	Remarks

Extra Maintenance and Check-ups you can do yourself:

Do you want ore tips and tricks on how to keep your bike in perfect condition? Check out the article: ['10 tips for the maintenance of a \(special needs\) bike'](#) on our website. In this article you can find tips about cleaning the bike, the seat padding, or for example how to maintain the battery of your E-Bike.



Delivery and service form Delivery and service form

Congratulations on your purchase of your Van Raam walking support. This walking support is produced with utmost care. To guarantee the quality as much as possible Van Raam produces the cycles according to the ISO 9001:2015 quality standards. Van Raam has been certified by DNV GL Business Assurance BV.

You will especially enjoy your Van Raam walking support when the walking support is adjusted to your specifications and when the instructions in the user manual are followed. Pay special attention on the service intervals who specified in the manual of the walking support.

To claim warranty and service you should always fill out this form, at least at delivery and service. This signed form declares that the end user had an instruction on the operation of the walking support, that the walking support is adjusted to the specifications of the end user and that the user manual is received.

Fill out when the walking support is delivered

Type Van Raam walking support:	
Frame number:	
Key number:	
Delivered to:	
By dealer:	
Place:	
Date:	
Signature user walking support:	Signature dealer:
When available, stamp dealer:	