

# User manual



**vanraam**  
Let's all cycle

Twinny



Twinny Plus



Kivo



Kivo tricycle



Van Raam BV  
Aaltenseweg 56  
7051 CM Varsseveld  
The Netherlands

Version 17.04

## Table of contents

Contact details manufacturer.....	1
Conformity .....	1
Introduction.....	2
Delivery .....	2
Indication.....	2
Intended usage.....	2
Safety measures .....	3
Adjustment of the bicycle.....	4
Before first use .....	7
Electro system Silent.....	12
Accessories .....	21
Technical details.....	31
Maintenance and adjustments to be done by owner.....	31
Repairs and maintenance to be done by dealer.....	32
Adjustments to be done by dealer.....	33
Disposal .....	35
Handover/sale to a new owner .....	35
Guarantee .....	35
Frame number.....	36
Form service, maintenance, modifications and warranty claims .....	37

## Contact details manufacturer

Van Raam BV  
Aaltenseweg 56  
7051 CM Varsseveld  
The Netherlands

Tel. : +31 (0)315 257370  
E-mail : info@vanraam.com  
Internet : www.vanraam.com

## Conformity

Van Raam declares as manufacturer that the Tandem bicycles, as described in this manual, are produced in accordance with the 93/42/EEG guidelines, risk category 1. All products have been produced in accordance with the 2006/42/EG guidelines. The declaration of conformity can be found on the Van Raam website.

## Introduction

This user manual provides important and necessary information about the use of your bicycle. We ask you to read this manual thoroughly before using the bicycle. Always follow all the instructions given in this manual.



**READ  
CAREFULLY!**

## Delivery

- Bicycle with packaging
- User manual(s)
- Possible chargers (depending on options)
- Spare key

Check the delivery immediately after receiving it. In case of damage or incomplete delivery we ask you to contact your dealer immediately. Upon delivery you should fill out the form “Form service, maintenance, modifications and warranty claims” in the back of this manual.

## Indication

The Twinny is intended for two adults where one person has difficulties participating independently in traffic, both have no problems with balance and movement and who think that social contact is important.

The Twinny Plus is intended for people who have difficulties participating independently in traffic, with one person or two persons have trouble with the balance and movement and think that social contact is important.

The Kivo and Kivo Plus are intended for two people, one adult and one child, where the child has difficulties participating independently in traffic, and want to participate under supervision in traffic.

## Intended usage

The tandem bicycle is designed for normal use on level and solid ground. The usual bicycle caution should always be taken into consideration. At the same time all safety instructions as described in this manual should be complied with explicitly. Also the local traffic rules should always be complied with.

The tandem is meant for two persons. The main driver should be independently mobile and may not have any serious visual or other impairments, which could adversely affect the controlling of the bicycle.

All other use, including damage or physical injuries due to this, are not the manufacturer's responsibility.

## Safety measures

- Ensure the bicycle is in good condition each time before using it. Check before **each** ride that the brakes are in order. Check the lighting and make sure there is enough tyre pressure.
- Regularly check if the wheels, the handlebars and the saddle are properly fixed and also whether all screw joints are tight.
- Only use the bicycle on a **solid and level surface**.
- Make sure that wide trousers or loose hanging clothing don't get caught in the chain, spokes or pedals.
- Do not use a pressure washer or a steam cleaner for the cleaning of the bicycle.
- Block (*Twinny Plus and Kivo tricycle*) the tricycle to stop it from moving when you are getting on or off the tricycle. Do this by using the parking brake and holding the tricycle.
- Always lock the bicycle when leaving it unattended.
- Make sure that no dangerous speed develops when driving downhill and entering tunnels. Brake on time and don't ride faster than 30 kilometres per hour.
- In case of pregnancy, extra care is required owing to a higher risk of injury.
- Do not put the bicycle in direct sunlight: the temperature of some parts could reach above 41°C resulting in possible hypersensitivity of the skin.
- In case that the bicycle is equipped with the Silent electric motor system, make sure that you get used to riding with electric support. Beware when you turn on the system and make sure you don't get startled by unexpected behaviour because you turned on the electric support. There is a reversing feature present on the Twinny Plus and Kivo tricycle. Practice the reverse function! Please be careful not to switch on the reverse function of the electric motor inadvertently.



**Extra attention** is essential if a child is using the bicycle!

- **Never** leave a child alone with the bicycle without supervision!
- **Always** have the child wear a bicycle helmet! Make sure the helmet fits correctly!

### Load

The maximum load should not be exceeded. See information in the index of technical details on page 31. By permitted load we mean the total load, including the load on the luggage rack.

Make sure that the permitted load on the luggage rack is not exceeded. (**maximum** 20 kg). People may not be transported on the luggage rack.

### Damaged or worn out parts

The replacement and repair of parts (frame, forks, light, brakes, drive mechanism and the handlebars) should **always** be performed by an authorised dealer. If not, the guarantee ceases to be valid and you will be personally responsible in the event of possible damage.



Specific safety parts should **always** be replaced by new parts!

## Adjustment of the bicycle

Before using the bicycle, adjust it to the measurements of the two cyclists. This is of great importance, especially the saddle and the handlebars.



*If an optimal adjustment of the bicycle, as defined in the instructions, is not possible, you can contact your dealer for a fitting solution.*

The brakes are correctly adjusted and should only be adjusted by the dealer during periodic maintenance.



Take care that fingers and limbs do not get trapped while adjusting the bicycle.

## Saddle height

When the cyclist is sitting on the bicycle and can put a foot on the pedal in the lowest position, the saddle height is correct. Adjust the saddle height in such a way that the leg is stretched but relaxed in that position.

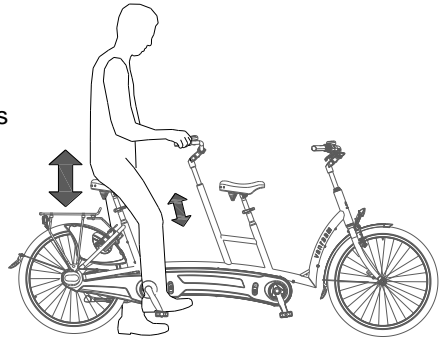

To adjust the saddle:

1. Open the quick-clamp [A].
2. Slide the saddle to the correct height.
3. Close the quick-clamp.



*Make sure clothing cannot get caught in the clamp!*



*If the clamp closes too easily, the clamping force is too low. In this case, open the clamp and tighten the nut [B] a bit more. If a lot of force is necessary to close the clamp, the nut should be loosened slightly.*

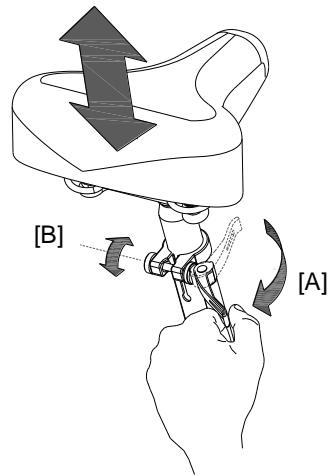

Do not pull out the saddle pin **further** than the marking. The tube will not go into the shank deep enough and will risk coming off. This can lead to serious injuries.



## Handlebars height

The height of the handle bars affects the comfort of the ride. It determines the pressure on the hands and the position of the back. Determine your own most comfortable height by using the bike.

To adjust the handlebars:

1. Slightly loosen the screw by using an Allen key.
2. Slide the handlebars to the correct height and tighten the screw very firmly again.

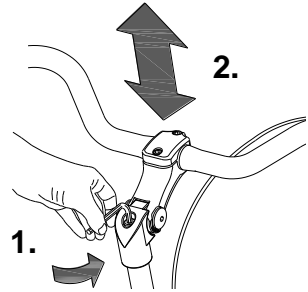

Do **not** pull out the handle bars **further** than the mark. Otherwise the tube will not be deep enough in the shaft and will risk coming off, which can lead to serious injuries.



## Position handle bars

You can tilt the handlebars. This influences the distance from the handlebar to the upper body. Determine your own most comfortable position by using the bike.

To tilt the handlebar:

1. Slightly loosen the screws [A] and [B] with an Allen key.
2. Put the handlebar in the desired position and then tighten the screws considerably.
3. Slightly loosen screw [C] with an Allen key, put the handlebar in the correct (horizontal) position and then tighten the screw again.

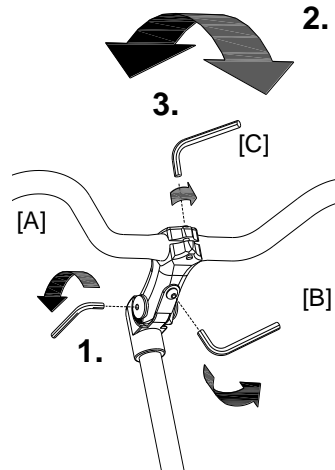

### Parking brake (Twinny Plus en Kivo tricycle)

Always use the parking brake if you park the bicycle and leave it behind.

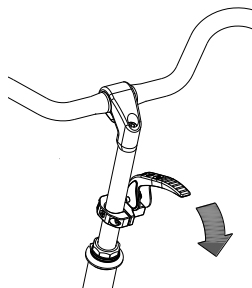

## Lights

### Headlight

The headlight has a switch (sliding switch) with three positions: **Off-Auto-On**.

The headlight can be manually switched on or off with the "On/Off" position.

In the "Auto" position, the headlight turns on or off automatically with the help of light- and movement sensors. When the bicycle stands still for a while, the light will automatically turn off.

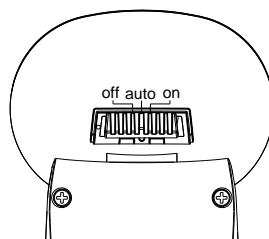

### Adjusting the headlight

Set the angle of the headlight such that the centre of the light beam falls approximately ten meters ahead of the bike.

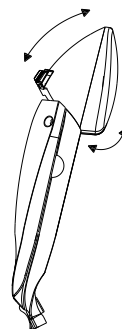

### Replacing batteries

The headlight works on batteries. When the batteries are almost empty, a red LED light flashes on the headlight. Follow the next steps to replace the batteries.

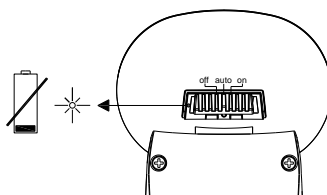



1. Remove the two screws at the back of the front light.

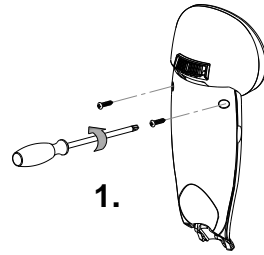

2. Dismantle the rear cover by pressing with the thumb and index finger at the cavity on both sides of the front cover and pulling the rear cover back.

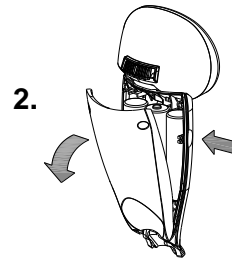

3. Replace the alkaline batteries (1.5 V - 1500 mA) and assemble the rear cover.

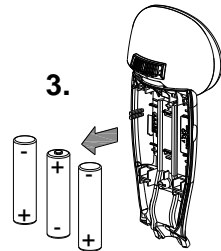

Only operate the lighting when stationary to avoid dangerous situations and the risk of personal injury. Advice: use the lighting in automatic mode.

## Rear light

The rear light has three options which you can choose by pressing the button repeatedly:

### On-Auto-Off.

The setting is as follows:

Press **1x**: light is on

Press **2x**: lighting is automatic

Press **3x**: light is off

With the "On" or "Off" mode, the rear light can be manually switched on and off.

With the "Automatic" mode the rear light automatically turns on and off with the help of light and movement sensors. When the bicycle stands still for a while, the light will automatically turn off.

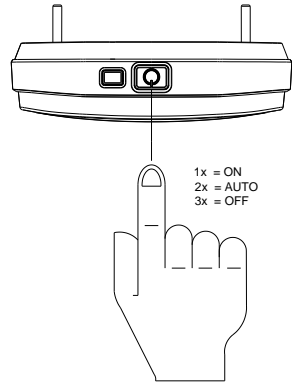

The rear light works on batteries. When the batteries are almost empty, a red LED light on the top starts flashing. To replace the batteries, follow the next steps.

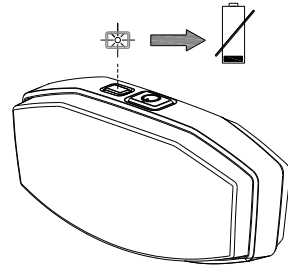

1. Dismantle the cover of the holder by pressing in the lip at the bottom of the light.

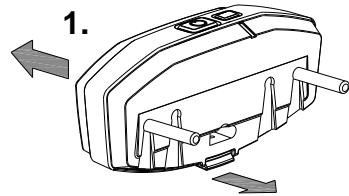

2. Replace the alkaline batteries (1,5 V - 1500 mA) and assemble the cover.

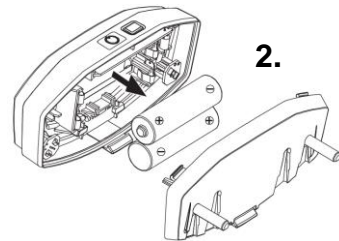

*Batteries cause environmental pollution. Follow the local regulations during disposal.*

## Gears

The bicycle has eight gears.  
The gears are used by turning the grip. **Do not use the pedals** when turning the grip.

**Option:** When your bike has an electric motor, there are six gears. **Now do use the pedals** when turning the grip.

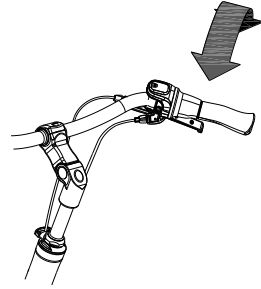

## Check before every ride:

- The brakes (including the parking brakes)
- The tyre pressure
- The lights
- That all parts are fitted properly
- That the battery is adequately charged (depends on options)

Contact your dealer and stop using your bicycle as soon as you observe irregularities during the check!

As with all mechanical parts, the bicycle is subject to wear tear and high loading. If a component fails, it can lead to very dangerous situations. This can lead to damage or injuries to the user of the bicycle. Any form of cracks, scratching or change in colour in heavily loaded parts or a component indicates that the component must be replaced.

## Points of interest during cycling

After you have adjusted the bicycle to the measurements of the cyclist, you can start using the bike.



The tricycle gives a very different ride experience than a bicycle!

Practice, in particular, with bends and braking, because a tricycle can react contrary to what you would expect. It may happen that the back wheel comes off the ground on the inside when going round a bend. To avoid this the rider leans towards the inside of the bend with his body.



If there is an electric motor on a bike: you must train with the acceleration function and reverse functions. Be careful that the acceleration mode or reverse mode are not unintentionally started while using the bike. For example, at traffic lights the reverse function can accidentally be activated and the bicycle reverses.



High speeds in the bends, driving on rough ground, and sharp bends can lead to the bicycle **falling over!**

### **Important safety points for the cyclist**

- Be very careful during the first ride.
- When riding the bicycle hold both hands firmly on the handlebars and feet on the pedals.
- Test the riding style of the bicycle on rough ground at moderate speed. This way the cyclist learns how to react to unexpected movements of the bicycle and the handlebars during use.
- Small obstacles should be cycled over with appropriate speed.
- Obstacles higher than five centimetre should be avoided.
- Ensure that no dangerous speed develops while driving downhill and entering tunnels. Brake on time.

The Silent Electric motor system is a special developed support system by Van Raam for the rehabilitation market. The system is characterized by:

1. A simplicity of operation
2. Individually adjustable support for cycling
3. Modern and efficient electronics
4. The powerful electric motors
5. High quality and safe batteries
6. Highly reliable system

The Silent system comes standard with a basic support mode individually programmed for your bike. In most cases, it gives precise and smooth cycling characteristics with a good compromise between support and radius of action.

In special cases, an individually tailor-made cycling program is necessary. You can obtain information from the dealer about the possibilities of a customised cycling program.

### Functions:

The electric system has the following functions:

- Pedal support while cycling
- Start support
- Backwards pedalling with support

### 1. On/off button

Using the on/off button, the electrical system can be switched on or off.

- Switching on: Push the button briefly.
- Switching off: Push the button for two seconds.

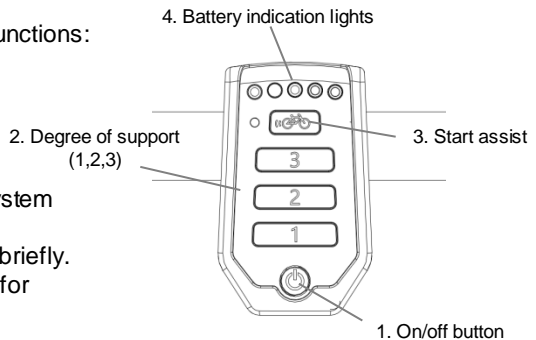

After the system is turned on, the electric motor is active in level 1.



*When the system is not used, it will automatically turn off after a certain time.*

With the option “integrated lighting”, the lights will automatically switch on when you turn on the electric motor system. You can switch the lights on and off by briefly pressing the on/off button in this mode.



Always turn off the electrical system when you are getting off the bicycle. Turn the electrical system on after you have taken up your riding position.

## 2. Degree of support 1, 2 and 3

The desired support can be set by using one of the support levels 1, 2 or 3.

1. Light support, maximum range.
2. Average support, average range.
3. Maximum support, low range.

You can change the level while cycling.

## 3. Start assist

The Silent electric motor has a start support. This allows the driver to pull-away without pedalling up to a speed of 6 km/h over five seconds. To accelerate, press the start assist button and keep it pressed down. The function will only activate again, when the support button has been pressed down again.

If you peddle normally, the function works for up to five seconds, each time the button is pressed, up to maximum speed of the bicycle (20-25 km/h).

The start assist is used for:

- Extra support when starting.
- Extra support for cycling uphill.



*Tip: when cycling a steep climb, you can use support in level 3 and push the start assist repeatedly for five seconds to achieve maximum support.*

## 4. Battery indication lights

The level of charge in the battery is given by five LED lights: four of these are green, the one on the left can show either green or red, if charge is low.

The battery is almost empty if only the last red LED light is on. The battery needs to be recharged or replaced by a (new) fully charged battery.

When the last red LED light flashes, the battery is empty and the motor will no longer support while cycling. The integrated lighting continues to work.



Never leave the bicycle with an empty battery!

Note: charge the battery within one day.



When the motor is not used for a while, the battery switches into the sleeping mode. This is to protect the batteries. To activate it, you can press the on/off button [A] on the battery and the indication lights will light up. You also can connect the battery to the charger for a few seconds or cycle the bike forwards (around 10 km/h) and push the on/off button to activate the system.

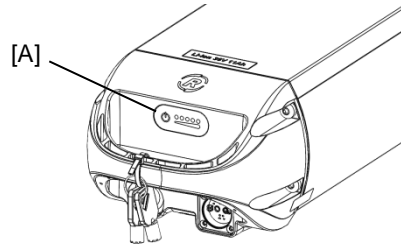

If you push the bicycle, turn off the motor.

If your battery is equipped with a button and indicator lights, the charge-level in the battery can be checked by pressing the button briefly. The five green lights indicate the level of charge in your battery, the left one of these, if flashing, given the lowest level. While charging the battery, these lights will also indicate how far the charging has progressed.

### Reverse mode (Twinny Plus and Kivo tricycle)

The reverse mode is activated by pedalling backwards from a standing position. Within a few seconds the motor is activated and the tricycle cycles at a speed of about 2 km/h backwards (when you start to pedal backwards).



Do not be startled by an unexpected reaction from the electrical system. If you e.g. wait for the traffic light and you play with the pedals by moving them backwards the reverse mode is activated and the tricycle cycles backwards.

### Bike application

The smart display is equipped with a Bluetooth connection. The Van Raam application can connect with the bike and track your bike data. In addition, settings can be changed while cycling. Once the smart display is ready to connect to the smartphone, the on/off button briefly turns blue. More information about the Van Raam application can be found on the Van Raam website.

### Other functions

The smart display has an automatic dimming function. With an inbuilt light sensor the lights of the display will automatically create less distraction for the cyclist in darker or more shadowy conditions.

## Charging the Battery

For the best performance and to prolong the life of the battery, we recommend that you charge the battery at home at room temperature.

To charge the battery:

1. Unlock the battery by turning the key a quarter.
2. Push down the lock while pulling the battery with your other hand.
3. Take the battery pack inside. **First** connect the charger to the plug-ensure contact of the battery. The magnetic plug of the charger directly connected properly to the battery.
4. **Then** connect the charger plug into the mains socket. Turn the switch [A] on. A green LED light on the charger will start to blink fast. Now the battery will recharge.



**Beware!** If the battery is not connected properly, the green LED light blinks slowly. In case of a poor contact, the connector of the charger needs to be cleaned.

5. Depending on the battery level, the charging time is about 2,5 hours for a battery of 11,2 Ah and 6 hours for a battery of 24,8 Ah.
6. Once the battery is fully charged, the green LED light stays on. **First** pull the plug from the mains socket or turn the switch [A] off.
7. **Then** pull the connector from the battery.
8. Put the battery back in the holder of the cycle and close the lock.

If necessary, the battery can also be charged directly on the cycle.

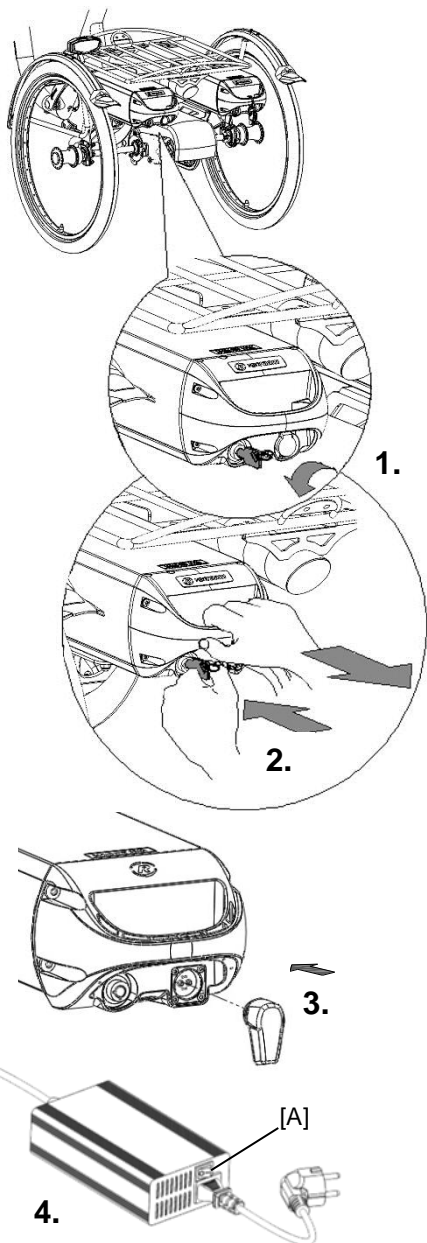

Do not wait until the battery is completely empty. It is better to top-up the battery regularly.





Ensure that the battery is always pushed straight into the holder.

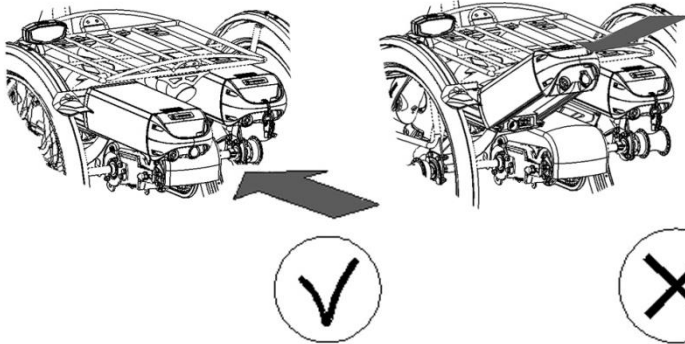

#### Backup battery: (optional)

The bike can be supplied with a second battery. When the first connected battery is empty, switch over to the second battery.

One of the battery holders is connected to the system; you can recognize this one because of the cables.

#### Switchable battery pack: (optional)

The bicycle may be fitted with a switchable battery pack. Once the connected battery is empty, you can swap the battery using a switch. This switch is located either under the seat, below the luggage rack or below one of the two batteries.

One of the battery holders is connected to the system, you can recognize this one because of the cables.

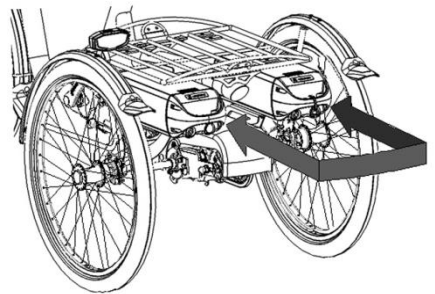

## Charging the Battery

For the best performance and to prolong the life of the battery, we recommend that you charge the battery at home at room temperature.

To charge the battery:

1. Unlock the battery by turning the key a quarter.
2. Pull the handle forward.
3. Take the battery pack from the holder.
4. Take the battery pack inside. **First** connected the charger into the plug contact of the battery.
5. **Then** connect the charger plug into the mains socket. Turn the switch [A] on. A green LED light on the charger will start to blink fast. Now the battery will recharge.



**Beware!** *If the battery is not connected properly, the green LED light blinks slowly. In case of a poor contact, the connector of the charger needs to be cleaned.*

6. Depending on the battery level, the charging time is about 2,5 hour.
7. Once the battery is fully charged, the green LED light stays on. Pull the plug from the mains socket **first** or turn the switch [A] off.
8. **Then** pull the connector from the battery.

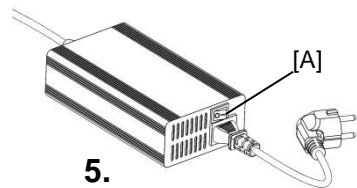
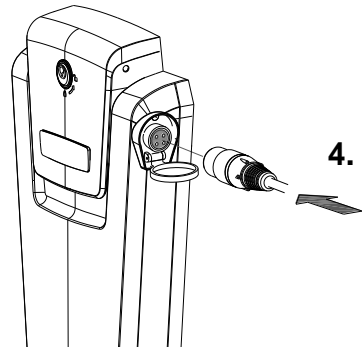
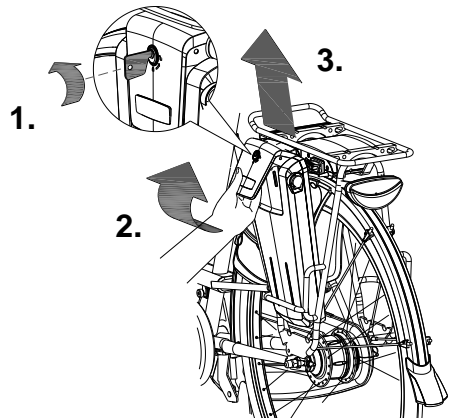

9. Put the battery back in the holder of the cycle. Slide it behind bar [A] and press it firmly on strip [B].
10. Pull the handle backwards and push the top of the battery to connect as shown in the drawing and close the lock.
11. Push the handle forward and close the lock.

It is also possible to charge the battery while it is still in the holder.



Do not wait until the battery is completely empty. It is better to recharge the battery interim.

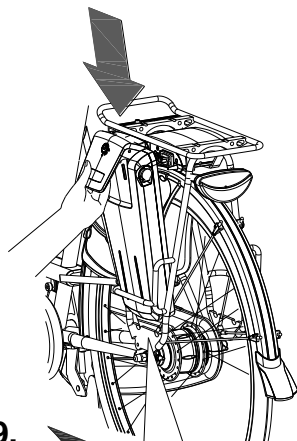

9.

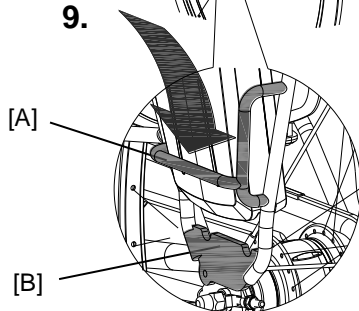

[A]

[B]

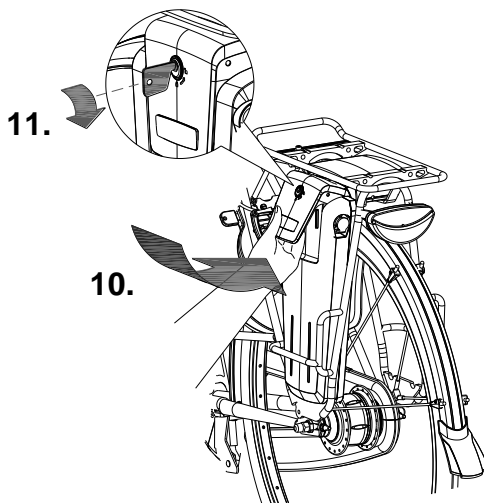

11.

10.



Make sure that the switch is set to the side the battery is placed.

### Backup battery (optional)

The bike can be supplied with a second battery.

To activate the second battery (when the first battery is empty) turn the switch under the luggage carrier to the right sight.

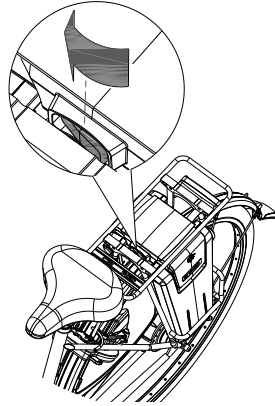

*Keep in mind that your bike provides less support when it's cold (0°C and less) and the battery will discharge faster. Charging also takes more time at lower temperatures.*



*The action radius depends on a lot of different factors and is strongly influenced by: capacity and voltage of the battery, degree of support that is used, temperature, wind speed, tyre pressure, cycling speed, weight of the user and the luggage, use of gearing etcetera.*

### Charging and maintenance tips for the battery



*Every battery discharges automatically over time. This process is called self-discharge. A battery that is empty and not charged, will self-discharge and will be deep discharged. The battery can be permanently damaged during this process. In case of deep discharge, the warranty will be void.*



*Please note that any battery will wear over time. The wearing process of the battery is inevitable and depends on several factors, such as usage, number of charge cycles and the ambient temperature. Even if the battery is not used, its capacity will decrease. A worn battery can still be used, but please bear in mind that its charge level may decrease.*

#### **Beware:**

- Never leave the bike with an empty battery! We advise you charge the battery as soon as possible before it's totally empty.
- The best storage-charge of the battery is when three to five LED lights burn.

- Check the battery every month in the winter. If fewer than three LED lights burn, recharge the battery.
- Preferably store and use the battery in environments of 5 to 20 degrees. Avoid higher or lower temperatures.
- Do not charge the battery in sunlight and make sure that the battery is not charged at a temperature of less than 5 degrees.
- Only use the charger indoors and in non-humid environments, the charger may *not* get wet.
- Only use the Van Raam supplied battery.
- Only charge the battery with the supplied charger!
- The battery housing and charger housing may never be opened! When there is a problem, contact your dealer.
- Don't drop the battery, this can cause external and internal damage.
- If your bicycle has a fault, the battery should be disconnected for the bicycle.



### **Problem solving**

- The system does not turn on:
  1. Make sure that the battery is properly attached.
  2. Check the status of the battery. If it is empty, recharge the battery.
  3. Make sure the battery is active. If the battery is not used a while, it will shut itself down. The battery can be reactivated by recharging it briefly, pushing and holding down the on/off button while cycling (less than 10km/h), or on certain batteries by pushing the indicator button on the battery until the indicator appears.
  4. If the above action does not help, contact your dealer.
- If the battery indicator LED lights on the display are flashing:  
The motor may be overheated by continuous high load. For protection, the system will reduce the support.
  1. The system is in temperature-protection. You can continue cycling with reduced support.
  2. After cooling down, the normal support and indication will restore automatically.
- If the support LED lights on the display are flashing:  
This indicates motor failure. You will need to contact your dealer.
- If a red LED light on the charger starts flashing, remove the plug from the mains outlet and do not longer use the charger. In this case, contact your dealer.

Depending on your order, you can use the accessories as described below.

### Crank shortener

The crank shortener is fitted to the crank, as illustrated. The pedal can then be fitted into the crank shortener at two positions.

With the Allen screw [A] the crank shortener should be aligned with the crank.

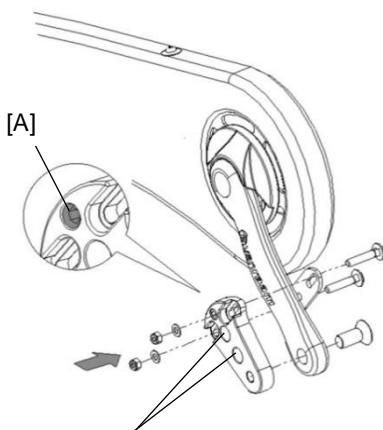

Two assembly points pedal

### Eccentric crank

The bicycle can be fitted with an eccentric crank on the left and/or right side. The illustration may differ from your crank, because it is custom made.

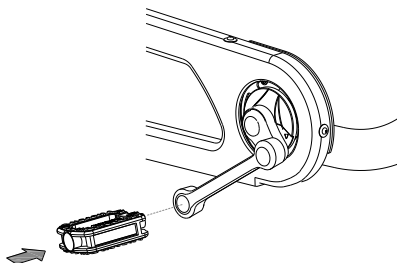

## Foot support

When using the foot support you can fix your foot by sliding the two straps [A] in the quick releases [B].

The quick release can be unlocked by pulling the lip to the rear. Now the strap can be pulled out.

You can cut the straps to size. The strap should retain a length of at least five centimetres.

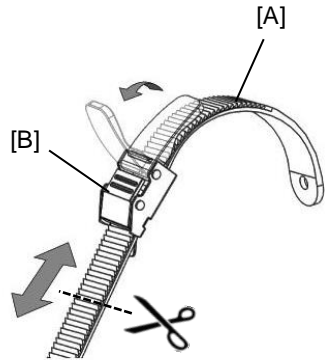

The position of the foot support on the pedal is adjustable in length. This allows you to pedal with the ball of your foot for better thrust.

1. Slightly loosen the four nuts with a socket wrench.
2. Slide the plate included the foot support forwards or backwards into the desired position. Then tighten the nuts again.

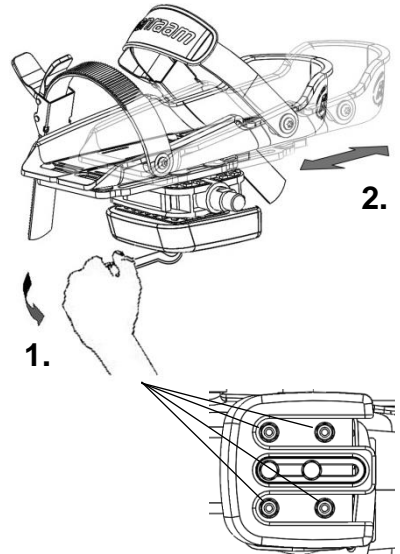

The foot support is also adjustable in width. Only the outer half of the foot support can be extended.

1. Slightly loosen the two screws with an Allen key.
2. Slide the adjustable half of the foot support to the desired position. Then tighten the screws again.

With the axel pedal extender the foot support can be extend further.

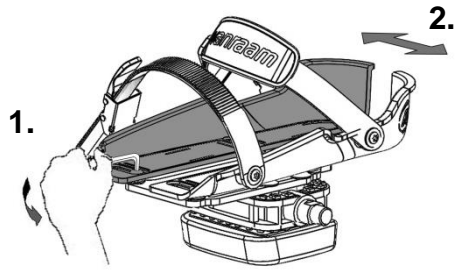

De foot support Fix20 is suitable for a foot of up to size 36. The foot support Fix 25 is suitable for size 36 to size 48.

The foot support returns to its neutral position when it is not used. The neutral position can be altered by shifting the balancing block.

1. Slightly loosen the two screws with a socket wrench.
2. Slide the balancing block to the desired position. Then tighten the screws again.

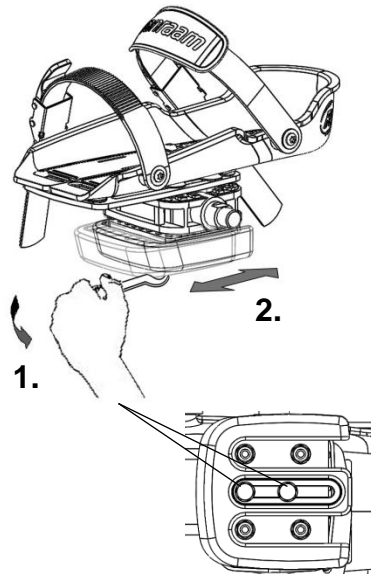



## Lower leg support

The balance block can no longer be used in combination with this option. To assemble the lower leg support:

1. First attach the lower leg support to the metal plate [A]. The lower leg support is attached to the inner side of the foot support.

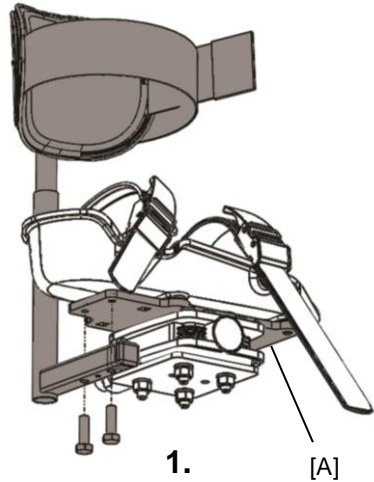

The image at the top shows Fix 20 with lower leg support, the image below shows Fix 25 with lower leg support.

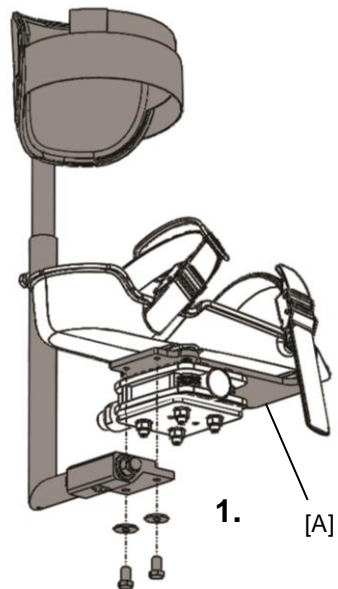

2. Adjust the height of the lower leg support in such a way that it is aligned with the lower leg of the rider.
3. The angle of the concave support is also adjustable. Rotate the concave support to the desired position.
4. Fix the elastic on the frame, so the lower leg support stays upright in its rest position.
5. Use the velcro to secure the lower leg of the rider.

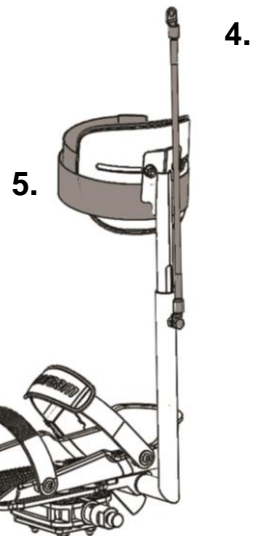
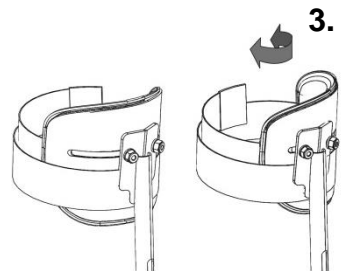
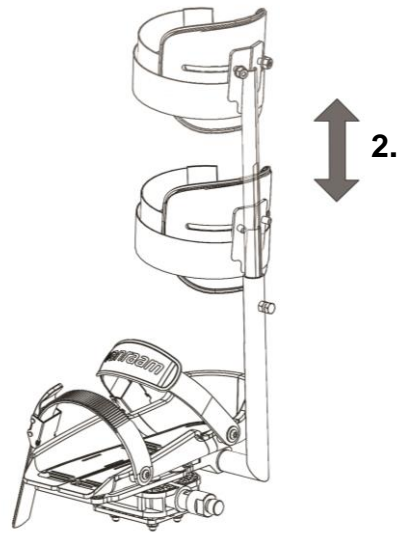

### Optional dividable frame (not a standard option with the Kivo)

The bicycle can be divided into two parts.

To divide the frame:

1. Put the bicycle on the standard and remove the grip from the handlebars. Push the pellets of the small spring [A] so that the grip can be removed from the handlebars.
2. Loosen the knob.
3. Remove the front part out of the coupling.

To assemble the bicycle again, follow these steps in reverse order.

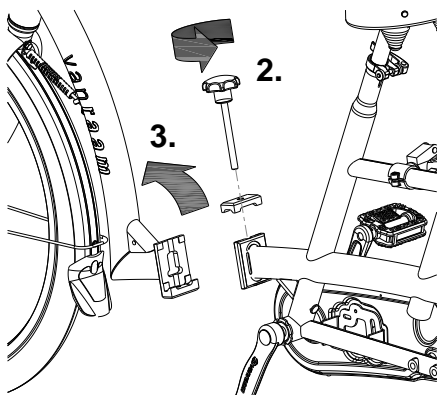
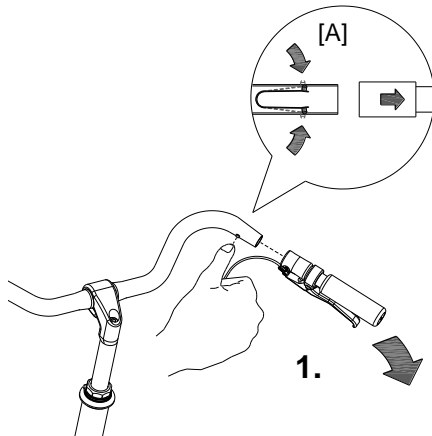

### Walking-stick holder

The walking-stick holder is fitted under the luggage rack. The walking-stick should be fastened with Velcro [A].

Walking-stick holder  
Twinny and Kivo:

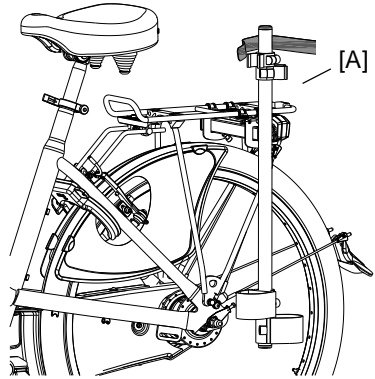

Walking-stick holder  
Twinny Plus and Kivo tricycle:

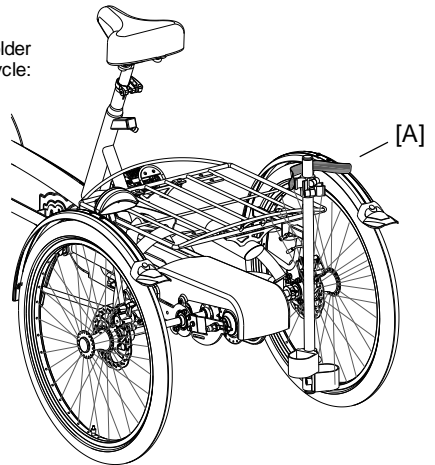

## Back support

Set the correct depth, by loosening the four bolts [A] with an Allen wrench, moving the handrail to the correct position and then tighten the screws again.

Then set the correct height by loosening the two bolts with an Allen wrench [B] so it can turn, shift the arms into the correct position, and then tighten the screws again.

The back support can be fitted with a belt [C]. Use the fastening device to open and close the belt.

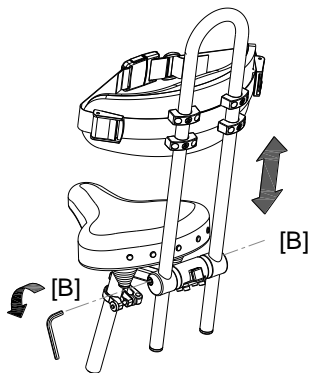
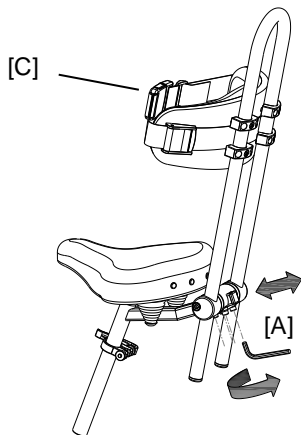

## Integrated lighting control

The bicycle can be fitted with a different headlight. This lighting is connected to the electrical system.

Adjust the angle of the headlamp. Make sure that the centre of the beam is approximately ten meters in front of the bike.

The headlight switches automatically on when the electrical system is activated. You can manually activate and deactivate the lights with a short press of the on/off button on the display. If the electrical system is switched off, the lighting turns off automatically.

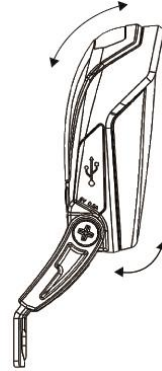

Once the battery is low, the motor will no longer provide support for cycling. The integrated lighting continues to work. However on the remaining charge.



The USB port, which is located on the headlight, has no function.

## Flashing light system

To use the flashing lights press the switch [A] to the left or right.

To turn off the indicators, move the switch to the centre position.

The lights work on a battery.  
To replace the batteries, turn the screw on the cap and take the orange cap [B] away. Then remove the PCB [C] from the holder. You can now replace the battery [D].

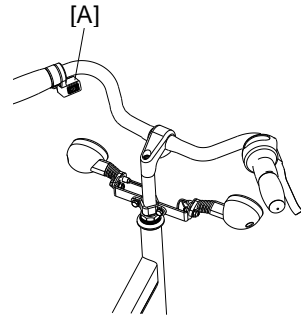

This is a 3-volt lithium battery, CR123A.



*Batteries cause environmental pollution. Follow the local regulations during disposal.*

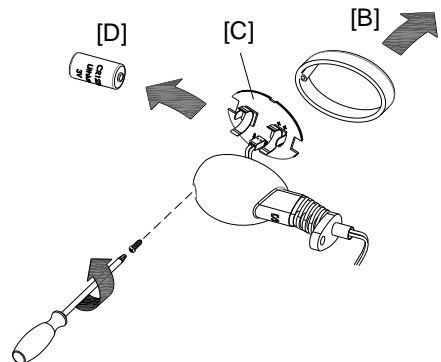

### Rear steering

The person in the rear steers the bicycle, the handlebars in the front are fixed.

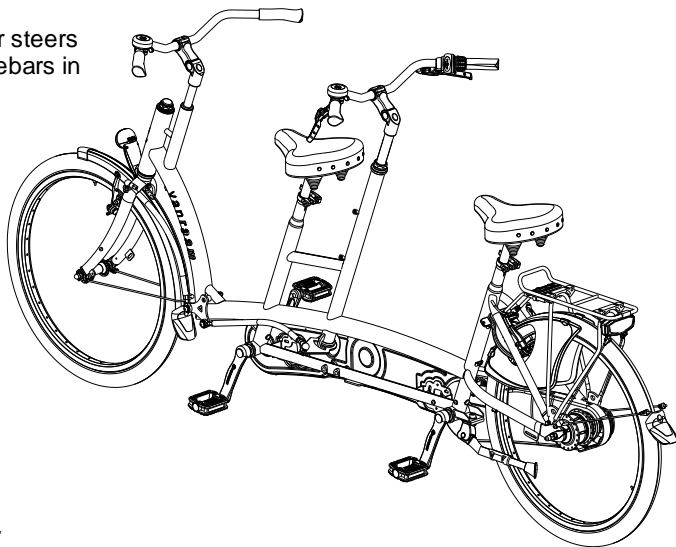

### Speed hub co-driver

The main driver can adjust the co-biking of the co-driver with the speed hub. There are two positions:

1. The pedals of the co-driver are moving together with the pedals of the main driver. The co-driver has to cycle also.
2. The pedals of the co-driver move independently of the pedals of the main driver. The pedals move free and the co-driver cannot cycle.

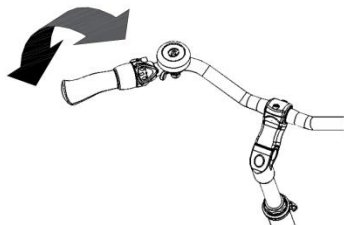

When steering from the rear, there is a third position. In that position the pedals of the co-driver move independently of the pedals of the main driver. The co-driver can cycle along independently.

Extra accessories are available at your dealer.

## Technical details

	Twinnny	Twinnny Plus	Kivo	Kivo driewiel
Length of inner leg (cm)	77-89	77-89	B: 77-89 F: 50-62 (restback: 52-68)	B: 77-89 F: 50-62 (restback: 52-68)
Frame height (cm)	52	52	A: 52 V: 30	A: 52 V: 30
Length (cm)	259	261	244	246
Width (cm)	66	75	66	75
Boarding height (cm)	A: 44 V: 37	A: 45 V: 37,5	A: 43 V: 36	A: 45 V: 36
Front wheel	26"	26"	20"	20"
Back wheel	26"	24"	26"	26"
Weight (kg)	Ca. 35 kg	Ca. 45 kg	Ca. 38 kg	Ca. 48 kg
Max. load luggage rack (kg)	20	20	20	20
Total max. load (kg)	260	260	240	240
Brakes, front	Hand brake	Hand brake	Hand brake	Hand brake
Brakes, back	Hand brake or back-pedal brake	Hand brake or back-pedal brake	Hand brake or back-pedal brake	Hand brake or back-pedal brake

## Maintenance and adjustments to be done by owner

Below you can find the instructions for maintenance and adjustments that you can do yourself on a regular basis, which will keep your bicycle in top condition.

### Cleaning

The frame of the bicycle can be cleaned with a damp cloth. For areas that are dirtier you can use a mild detergent.

The wheels can be cleaned with a moist brush with plastic hairs (not a wire brush!).

The saddle and the grips can be cleaned with mild soap and water.



Do not use a pressure washer or a steam cleaner!

### The right lubricant

The chain should be cleaned and maintained at regular intervals (every three months approximately). Only use special chain grease or Teflon spray. This is the only way to make sure that the chain will run smoothly, will stay water resistant and will not rust.

1. Wipe the chain with a cloth.
2. Treat it with grease or spray.
3. Remove any excess lubricant with a rag.

Other parts should **not** be treated with a lubricant.



### **Inspection of the bicycle**

It is recommended that the bicycle has a yearly inspection carried out by the dealer to claim warranty. Please use the form "Form service, maintenance, modifications and warranty claims" in the back of this manual. After 200 kilometres or after a period of two months the bicycle should be inspected.

In the event of technical trouble or faults, the bicycle should be taken to the dealer for repairs **immediately**.

The replacing of safety-related components (especially frame, brakes, lighting, handlebars, front fork and actuation) should be performed by the dealer.

If you still decide you want to replace components yourself, you are responsible for damage or harm due to incorrectly fitted components.

Only use **original** Van Raam spare parts, which you can buy at your dealer. If requested the dealer will make the necessary information on repair and maintenance available.

### **Repairs and maintenance to be done by dealer**

Check the brakes, the rims, lighting, the chain tension and the spokes. Also check the tyre tread depth. This should be at least one millimetre. Worn out tyres or possible faulty parts should be replaced. Also check the parking brake. With the parking brake pulled up, the bicycle should not ride away with the cyclist.

#### **Checking the rim**

Due to the combined action of the brake and the rims, not only the brake lining but also the condition of the rim is important. For this reason the rim should be checked at regular intervals, for example when you inflate the tyres. The presence of fine cracks in the spoke punches or deformation of the rim when there is higher air pressure, indicate more serious wear and tear. In that case the rim should be replaced, because it can lead to loss of brake function or even a crack in the rim, which can lead to all kinds of dangerous consequences.

Repairs, maintenance and modifications should only be performed with original Van Raam parts.

### The correct tension of the chain

There are two chains on the bicycle. The chain should not be too tight. It should hang loose. Without effort you should be able to move the chain up and down, half a centimetre approximately.

#### Chain Twinny en Kivo:

To keep the chain tension correct, the back wheel axle is adjusted. Follow the instructions below to adjust the chain tension:

1. Slightly loosen the nuts of the back wheel axle, so that the back wheel can move backwards and forwards.
2. Tension the nuts on the two chain-tensioners, so that the wheel slides backwards and the chain gains tension. Do this in such a way that the chain hangs loosely, like described earlier.

**Note:** Tension the nuts the same amount of turns, so that the wheel is straight and positioned in the centre of the frame, as illustrated. Not to the left or right, see figure [A].

3. Slightly tighten the nuts of the back wheel axle.
4. Check whether the chain tension is correct and whether the wheel is straight and in the centre of the frame.
5. Tighten the nuts thoroughly.

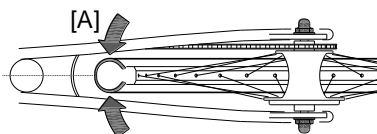
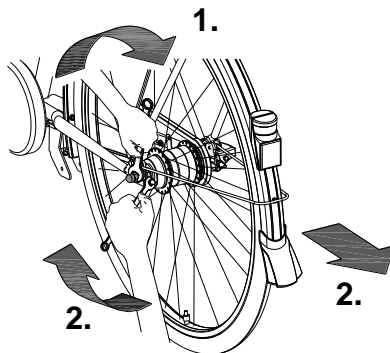

Chain Twinny (Plus) and Kivo (tricycle):

To keep the chains on the front of the bicycle tight, secure two chain tension wheels on the bike. Follow the instructions below to adjust the chains to the correct tension so the chain tension wheels do not become loose:

1. Loosen the cap nut a few turns.
2. Move the chain tension wheel, so that the chain is under light tension, as described above.
3. Tighten the cap nut again.

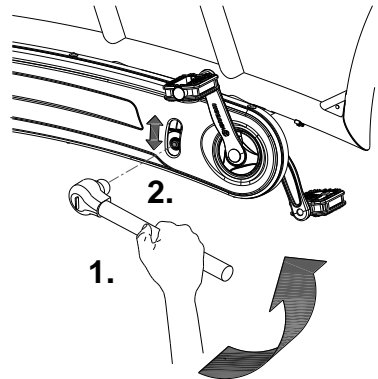
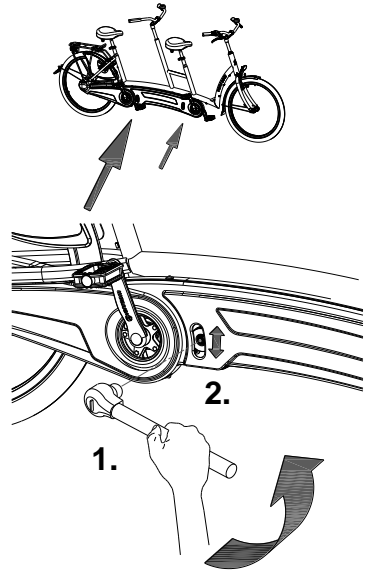

## Disposal

If you want to dispose your bicycle, contact your dealer. You can also contact the local waste disposal company. They will dispose the bicycle according to the regulations of your town.

## Handover/sale to a new owner

When you hand over your bicycle to a new owner it is important that you also hand over all necessary technical documentation and spare keys, so that the new owner can use the bicyclesafely.

## Guarantee

The guarantee is valid for all faults in the product, which are proven to be caused by material or manufacturing error.

We give a guarantee of five years on the frame and the front fork. For all accessories and other parts (except wear parts) we provide a two year guarantee, as legally regulated. The guarantee only applies by normal use and maintenance of the bicycle, as described in this manual.

### **Beware!**

The guarantee as well as the product liability in general expires if the instructions stated in this manual are not followed. This is also the case if unauthorized maintenance is carried out or if technical changes or additions are made with non-original Van Raam parts without permission of Van Raam. The original CE certification will become nul-and-void if modifications are done by third parties. The absence of the certification can lead to problems in insuring your bike, and for any loss or incurred.

## Frame number

The frame number is printed on the sticker. This sticker is located on the frame, see the images below.

Example sticker:



The position of the sticker:

On the saddle tube



On the saddle tube



On the saddle tube



On the saddle tube



## Form service, maintenance, modifications and warranty claims

To maintain warranty on the Van Raam bicycle, follow this service schedule.

Service:	Carried out (date):	Signature dealer:
Service after the first 200 KM or two months.		
Service 1 year after delivery.		
Service 2 year after delivery.		
Service 3 year after delivery.		
Service 4 year after delivery.		
Service 5 year after delivery.		

Even after five years, we advise you to give your bike annual service. Passing by the service after five years will have no further effect on warranty claim because it expires for certain parts after five years.

### Modifications to the bike

The following items are changed to the bike:

Changed:

Date:

Carried out:

**Beware!** Please note that if changes are made by a non-authorized Van Raam dealer or no original Van Raam parts or options are used, warranty may void.









## Delivery and service form

Congratulations on your purchase of your Van Raam bicycle. This bike is produced with utmost care. To guarantee the quality as much as possible Van Raam produces the cycles according to the ISO 9001 : 2008 quality standards. Van Raam has been certified by TÜV Rheinland Netherlands BV.

You will especially enjoy your Van Raam bike when the bike is adjusted to your specifications and when the instructions in the user manual are followed. Pay special attention on the service intervals who specified in the manual of the bike.

To claim warranty and service you should always fill out this form, at least at delivery and service. This signed form declares that the end user had an instruction on the operation of the bicycle, that the bicycle is adjusted to the specifications of the end user and that the user manual is received.

### Fill out when the bicycle is delivered

Type Van Raam bicycle:	
Frame number:	
Key number:	
Delivered to:	
By dealer:	
Place:	
Date:	
Signature user bike:	Signature dealer:
When available, stamp dealer:	