

User manual



vanraam
Let's all cycle



Velo Plus²



Van Raam BV
Aaltenseweg 56
7051 CM Varsseveld
The Netherlands

Version 16.05

Table of contents

Contact details manufacturer.....	1
Conformity.....	1
Introduction.....	2
Delivery.....	2
Intended usage.....	2
Safety measures.....	3
Adjustment of the tricycle.....	4
Before the first use.....	9
Electro system Silent.....	14
Accessories.....	21
Technical details.....	24
Maintenance and adjustments to be done by owner.....	24
Repairs and maintenance to be done by dealer.....	25
Adjustments to be done by dealer.....	25
Disposal.....	26
Handover/sale to a new owner.....	26
Guarantee.....	26
Frame number.....	27
Form service, maintenance, modifications and guarantee claims.....	28

Contact details manufacturer

Van Raam BV
Aaltenseweg 56
7051 CM Varsseveld
The Netherlands

Tel. : +31 (0)315 257370
E-mail : info@vanraam.com
Internet : www.vanraam.com

Conformity

Van Raam declares as manufacturer that the Velo-Plus² tricycle, as described in this manual, has been produced in accordance with the 93/42/EEG guidelines, risk category 1. All products have been produced in accordance with the 2006/42/EG guidelines. The declaration of conformity can be found on the Van Raam website.

Introduction

This user manual provides important and necessary information about the use of your tricycle. We ask you to read this manual thoroughly before using the tricycle. Always follow all the instructions given in this manual.



**READ
CAREFULLY!**

Delivery

- Tricycle with packaging
- User manual(s)
- Possible chargers (depending on options)
- Spare key

Check the delivery immediately after receiving it. In case of damage or incomplete delivery we ask you to contact your dealer immediately. Upon delivery you should fill out the form "Form service, maintenance, modifications and warranty claims" in the back of this manual.

Intended usage

The tricycle is designed for normal use on level and solid ground. The usual tricycle caution should always be taken into consideration. At the same time all safety instructions as described in this manual should be complied with explicitly. Also the local traffic rules should always be complied with.

The tricycle is meant for two persons, one driver and one passenger in his/her own wheelchair. The driver should be independently mobile and may not have any serious visual or other impairments, which could adversely affect the controlling of the tricycle.

All other use, including damage or physical injuries due to this, are not the manufacturer's responsibility.

Safety measures

- Ensure the tricycle is in good condition each time before using it. Check before **each** ride that the brakes are in order. Check the lighting and make sure there is enough tyre pressure.
- Regularly check if the wheels, the handlebars and the saddle are properly fixed and also whether all screw joints are tight.
- Only use the tricycle on a **solid and level surface**.
- Make sure that wide trousers or loose hanging clothing don't get caught in the chain, spokes or pedals.
- Do not use a pressure washer or a steam cleaner for the cleaning of the tricycle.
- Block the tricycle to stop it from moving when you are getting on or off the tricycle. Do this by using the parking brake and holding the tricycle. Also use the parking brake if the wheelchair is driven on or off the ramp.
- Always lock the tricycle when leaving it unattended.
- **Never** drive without a passenger. This will cause instability of the bike and will lead to dangerous situations.
- **Never** place your feet or other limbs under the ramp. You can be hit by moving parts and suffer from bruises.
- Always place the wheelchair in the driving direction.
- Make sure that no dangerous speed develops when driving downhill and entering tunnels. Brake on time and don't ride faster than 30 kilometres per hour.
- In case of pregnancy, extra care is required owing to a higher risk of injury.
- Do not put the tricycle in direct sunlight: the temperature of some parts could reach above 41°C resulting in possible hypersensitivity of the skin.
- In case that the tricycle is equipped with the Silent electric motor system, make sure that you get used to riding with electric support. Beware when you turn on the system and make sure you don't get startled by unexpected behaviour because you turned on the electric support.

Load

The maximum load should not be exceeded. See information in the index of technical details on page 24. By permitted load we mean the total load, including the load on the luggage rack and the wheelchair.

Make sure that the permitted load on the luggage rack is not exceeded. (**maximum** 20 kg). People may not be transported on the luggage rack!

Damaged or worn out parts

The replacement and repair of parts (frame, forks, light, brakes, drive mechanism and the handlebars) should **always** be performed by an authorised dealer. If not, the guarantee ceases to be valid and you will be personally responsible in the event of possible damage.



Specific safety parts should **always** be replaced by new parts!

Adjustment of the tricycle

Before using the tricycle, adjust it to the measurements of the cyclist. This is of great importance, especially the saddle and the handlebars.



If an optimal adjustment of the tricycle, as defined in the instructions, is not possible, you can contact your dealer for a fitting solution.

The brakes are correctly adjusted and should only be adjusted by the dealer during periodic maintenance.



Take care that fingers and limbs do not get trapped while adjusting the tricycle.

Saddle height

When the cyclist is sitting on the tricycle and can put a foot on the pedal in the lowest position, the saddle height is correct. Adjust the saddle height in such a way that the leg is stretched but relaxed in that position.

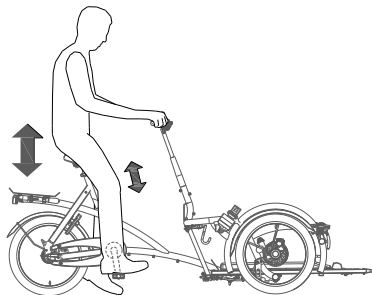

To adjust the saddle:

1. Open the quick-clamp [A].
2. Slide the saddle to the correct height.
3. Close the quick-clamp.



Make sure clothing cannot get caught in the clamp!



If the clamp closes too easily, the clamping force is too low. In this case, open the clamp and tighten the nut [B] a bit more. If a lot of force is necessary to close the clamp, the nut should be loosened slightly.

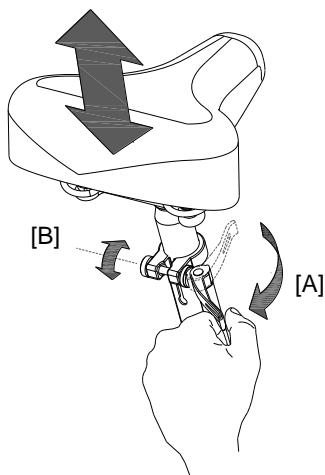

Do not pull out the saddle pin **further** than the marking. The tube will not go into the shank deep enough and will risk coming off. This can lead to serious injuries.



Handlebars height

The height of the handle bars affects the comfort of the ride. It determines the pressure on the hands and the position of the back. Determine your own most comfortable height by using the bike.

To adjust the handlebars:

1. Slightly loosen the screw by using an Allen key.
2. Slide the handlebars to the correct height and tighten the screw very firmly again.

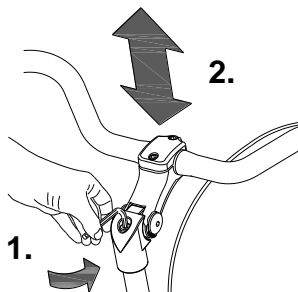

Do **not** pull out the handle bars **further** than the mark. Otherwise the tube will not be deep enough in the shaft and will risk coming off, which can lead to serious injuries.



Position handle bars

You can tilt the handlebars. This influences the distance from the handlebar to the upper body. Determine your own most comfortable position by using the bike.

To tilt the handlebar:

1. Slightly loosen the screws [A] and [B] with an Allen key.
2. Put the handlebar in the desired position and then tighten the screws considerably.
3. Slightly loosen screw [C] with an Allen key, put the handlebar in the correct (horizontal) position and then tighten the screw again.

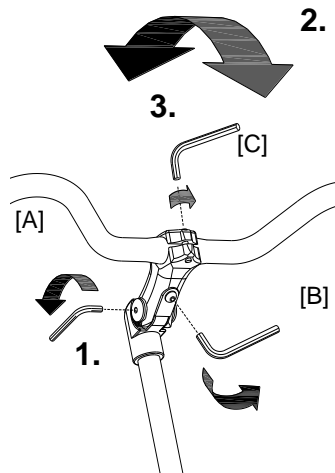

Steering damper

The steering damper affects the stability during steering. By adjusting the screw, steering gets more rigid and stability will increase. Determine your own most comfortable setting for using the bike.

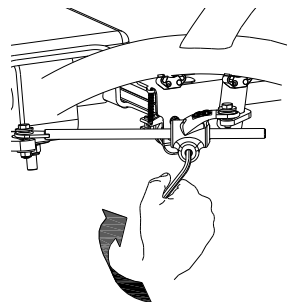

Wheelchair transport

If you want to transport a wheelchair on the Velo-Plus², follow the instructions below.

1. Attach the parking brake to the bike by squeezing the left brake [A] and lock it with the pin [B].
2. Remove the safety pin.
3. Pull the handle up so the ramp unlocks and falls down.
4. Push the wheelchair backwards on the ramp. Push the wheelchair until the ramp is tilting and locks itself automatically with a clear noticeable click.
5. Attach the wheelchair with the three belts. Push the button to release the belt and attach the hooks to the wheelchair.

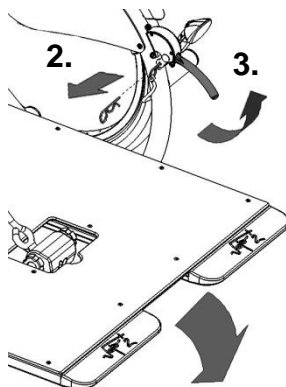
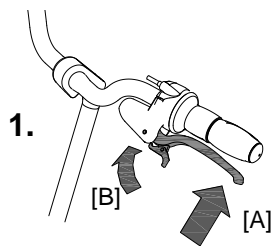

Be sure that the ramp is locking!
Failing to do so may result in serious injuries.
If the ramp does not lock properly then use your foot [A] to push until the ramp locks.

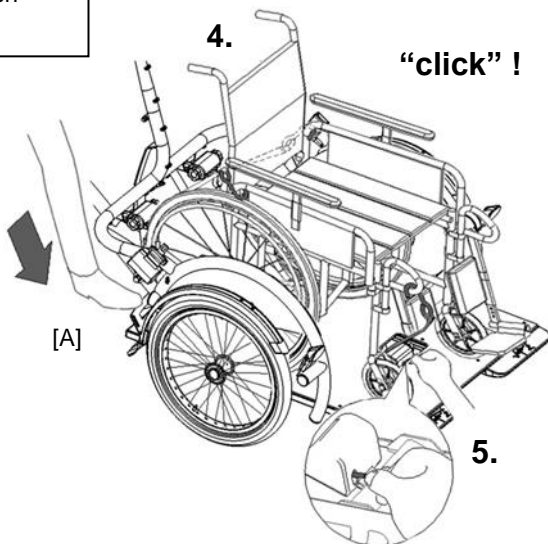

6. Next, turn the star knob to tighten the belts.
7. Finally fasten the safety belt of the passenger.
8. Replace the safety pin in the coupling.

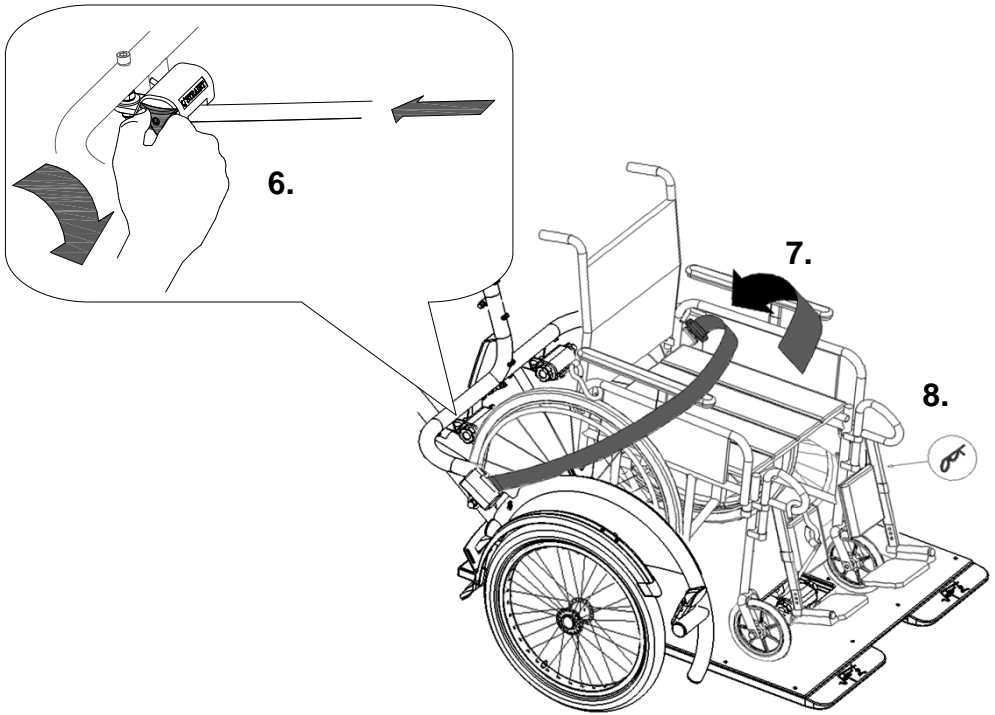

To remove the wheelchair from the bike, follow these steps in reverse order.



Caution: Stop the wheelchair when you release the hooks so that it will not roll off the ramp.

Parking brake

Always use the parking brake if you park the tricycle and leave it behind.

To operate the parking brake, squeeze the left brake [A] and lock it with the pin [B].

By squeezing the brake again it will unlock itself.

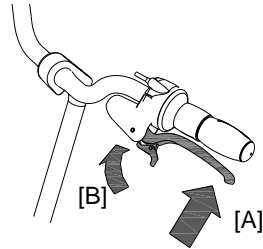

Lights

Headlight

The headlight has a switch (sliding switch) with three positions: **Off-Auto-On**.

The headlight can be manually switched on or off with the "On/Off" position.

In the "Auto" position, the headlight turns on or off automatically with the help of light- and movement sensors. When the tricycle stands still for a while, the light will automatically turn off.

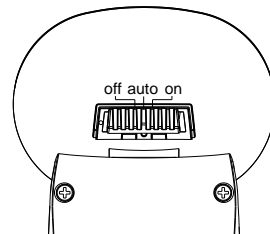
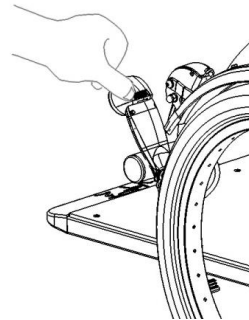

Adjusting the headlight

Set the angle of the headlight such that the centre of the light beam falls approximately ten meters ahead of the bike.

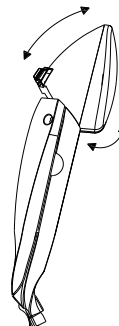

Replacing batteries

The headlight works on batteries. When the batteries are almost empty, a red LED light flashes on the headlight. Follow the next steps to replace the batteries.

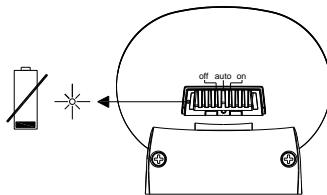

1. Remove the two screws at the back of the front light.

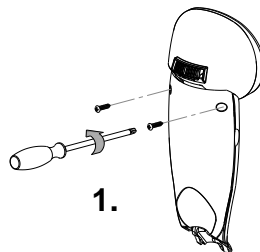

2. Dismantle the rear cover by pressing with the thumb and index finger at the cavity on both sides of the front cover and pulling the rear cover back.

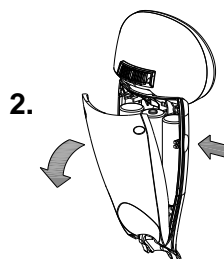

3. Replace the alkaline batteries (1.5 V - 1500 mA) and assemble the rear cover.

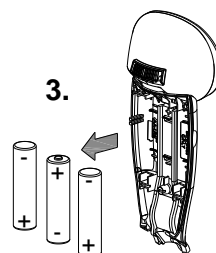

Only operate the lighting when stationary to avoid dangerous situations and the risk of personal injury. Advice: use the lighting in automatic mode.

Rear light

The rear light has three options which you can choose by pressing the button repeatedly: **On-Auto-Off**.

The setting is as follows:

Press **1x**: light is on

Press **2x**: lighting is automatic

Press **3x**: light is off

With the "On" or "Off" mode, the rear light can be manually switched on and off.

With the "Automatic" mode the rear light automatically turns on and off with the help of light and movement sensors. When the tricycle stands still for a while, the light will automatically turn off.

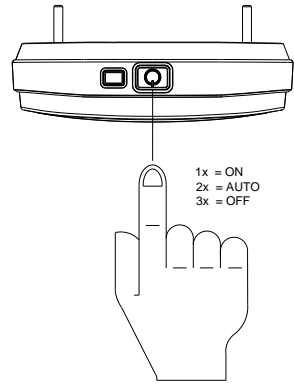

The rear light works on batteries. When the batteries are almost empty, a red LED light on the top starts flashing. To replace the batteries, follow the next steps.

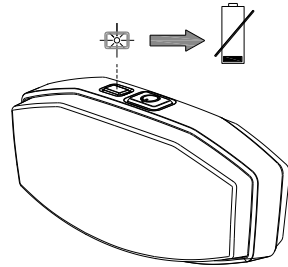

1. Dismantle the cover of the holder by pressing in the lip at the bottom of the light.

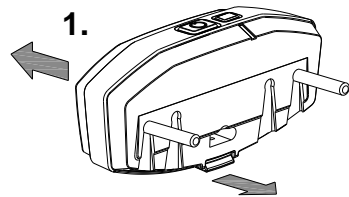

2. Replace the alkaline batteries (1,5 V - 1500 mA) and assemble the cover.

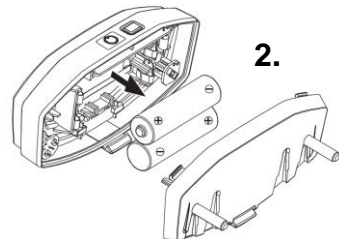

Batteries cause environmental pollution. Follow the local regulations during disposal.

Gears

Standard the tricycle has eight gears. The gears are used by turning the grip. **Do not use the pedals** when turning the grip.

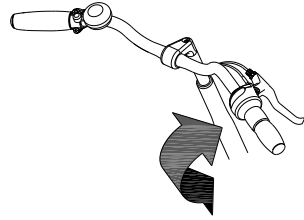

Option: When your bike has an electric motor, there are six gears. **Now do use the pedals** when turning the grip.

Check before every ride:

- The brakes (including the parking brakes)
- The tyre pressure (recommended: 3 bar)
- The lights
- That all parts are fitted properly
- That the battery is adequately charged (depends on options)

Contact your dealer and stop using your tricycle as soon as you observe irregularities during the check!

As with all mechanical parts, the tricycle is subject to wear tear and high loading. If a component fails, it can lead to very dangerous situations. This can lead to damage or injuries to the user of the tricycle. Any form of cracks, scratching or change in colour in heavily loaded parts or a component indicates that the component must be replaced.

Points of interest during cycling

After you have adjusted the tricycle to the measurements of the cyclist, you can start using the bike.



The tricycle gives a very different ride experience than a bicycle!

Practice, in particular, with bends and braking, because a tricycle can react contrary to what you would expect. It may happen that the back wheel comes off the ground on the inside when going round a bend. To avoid this the rider leans towards the inside of the bend with his body.



High speeds in the bends, driving on rough ground, and sharp bends can lead to the tricycle **falling over!**

Important safety points for the cyclist

- Be very careful during the first ride.
- When riding the tricycle hold both hands firmly on the handlebars and feet on the pedals.
- Test the riding style of the tricycle on rough ground at moderate speed. This way the cyclist learns how to react to unexpected movements of the tricycle and the handlebars during use.
- Explore how the tilting movements of the tricycle react to body posture. Tilt to the inside of the bend.
- Small obstacles should be cycled over with appropriate speed.
- Obstacles higher than five centimetre should be avoided.
- Ensure that no dangerous speed develops while driving downhill and entering tunnels. Brake on time.

Electro system Silent

The Silent Electric motor system is a special developed support system by Van Raam for the rehabilitation market. The system is characterized by:

1. A simplicity of operation
2. The powerful electric motors
3. Modern and efficient electronics
4. Extremely high quality and safe batteries
5. Individually adjustable support for cycling

The Silent system comes standard with a basic support mode individually programmed for your bike. In most cases, it gives precise and smooth cycling characteristics with a good compromise between support and radius of action.

In special cases, an individually tailor-made cycling program is necessary. You can obtain information from the dealer about the possibilities of a customised cycling program.

Functions:

The electric system has the following functions:

- Pedal support while cycling
- Start support
- Backwards pedalling with support

1. On/off button

Using the on/off button, the electrical system can be switched on or off.

- Switching on: Push the button briefly.
- Switching off: Push the button for two seconds.

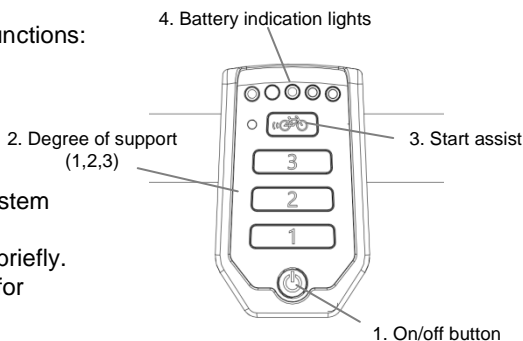

After the system is turned on, the electric motor is active in level 1.



When the system is not used, it will automatically turn off after a certain time.

With the option “integrated lighting”, the lights will automatically switch on when you turn on the electric motor system. You can switch the lights on and off by briefly pressing the on/off button in this mode.



Always turn off the electrical system when you are getting off the bicycle.
Turn the electrical system on after you have taken up your riding position.

2. Degree of support 1, 2 and 3

The desired support can be set by using one of the support levels 1, 2 or 3.

1. Light support, maximum range.
2. Average support, average range.
3. Maximum support, low range.

You can change the level while cycling.

3. Start assist

The Silent electric motor has a start support. This allows the driver to pull-away without pedalling up to a speed of 6 km/h over five seconds. To accelerate, press the start assist button and keep it pressed down. The function will only activate again, when the support button has been pressed down again.

If you peddle normally, the function works for up to five seconds, each time the button is pressed, up to maximum speed of the bicycle (20-25 km/h).

The start assist is used for:

- Extra support when starting.
- Extra support for cycling uphill.



Tip: when cycling a steep climb, you can use support in level 3 and push the start assist repeatedly for five seconds to achieve maximum support.

4. Battery indication lights

The level of charge in the battery is given by five LED lights: four of these are green, the one on the left can show either green or red, if charge is low.

The battery is almost empty if only the last red LED light is on. The battery needs to be recharged or replaced by a (new) fully charged battery.

When the last red LED light flashes, the battery is empty and the motor will no longer support while cycling. The integrated lighting continues to work.



Never leave the bicycle with an empty battery!
Note: charge the battery within one day.



When the motor is not used for several days, the battery switches into the sleeping mode. This is to protect the batteries. To activate it, you must connect the battery to the charger for a few seconds or cycle the bike forwards (around 10 km/h) and push the on/off button to activate the system.



If you push the bicycle, turn off the motor.

Reverse mode

The reverse mode is activated by pedalling backwards from a standing position. Within a few seconds the motor is activated and the tricycle cycles at a speed of about 2 km/h backwards (when you start to pedal backwards).



Do not be startled by an unexpected reaction from the electrical system. If you e.g. wait for the traffic light and you play with the pedals by moving them backwards the reverse mode is activated and the tricycle cycles backwards.

Bike application

The smart display is equipped with a Bluetooth connection. The Van Raam application can connect with the bike and track your bike data. In addition, settings can be changed while cycling. Once the smart display is ready to connect to the smartphone, the on/off button briefly turns blue. More information about the Van Raam application can be found on the Van Raam website.

Other functions

The smart display has an automatic dimming function. With an inbuilt light sensor the lights of the display will automatically creating less distraction for the cyclist in darker or more shadowy conditions.

Charging the Battery

For the best performance and to prolong the life of the battery, we recommend that you charge the battery at home at room temperature.

To charge the battery:

1. Unlock the battery by turning the key a quarter.
2. Pull the handle forward.
3. Take the battery pack from the holder.
4. Take the battery pack inside. **First** connected the charger into the plug contact of the battery.
5. **Then** connect the charger plug into the mains socket. Turn the switch [A] on. A green LED light on the charger will start to blink fast. Now the battery will recharge.



Beware! *If the battery is not connected properly, the green LED light blinks slowly. In case of a poor contact, the connector of the charger needs to be cleaned.*

6. Depending on the battery level, the charging time is about 2,5 hour.
7. Once the battery is fully charged, the green LED light stays on. Pull the plug from the mains socket **first** or turn the switch [A] off.
8. **Then** pull the connector from the battery.

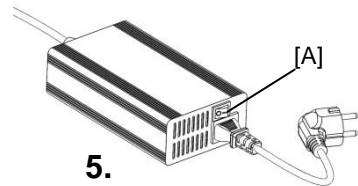
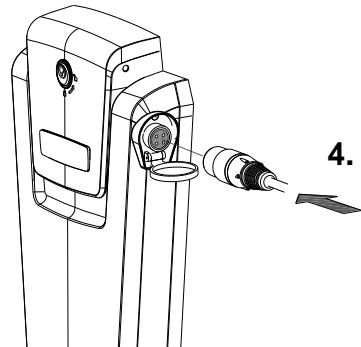
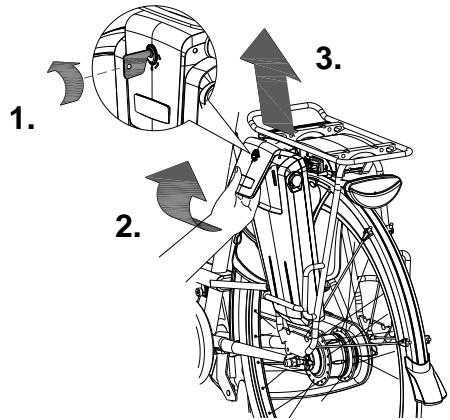

9. Put the battery back in the holder of the cycle. Slide it behind bar [A] and press it firmly on strip [B].
10. Pull the handle backwards and push the top of the battery to connect as shown in the drawing and close the lock.
11. Push the handle forward and close the lock.

It is also possible to charge the battery while it is still in the holder.



Do not wait until the battery is completely empty. It is better to recharge the battery interim.

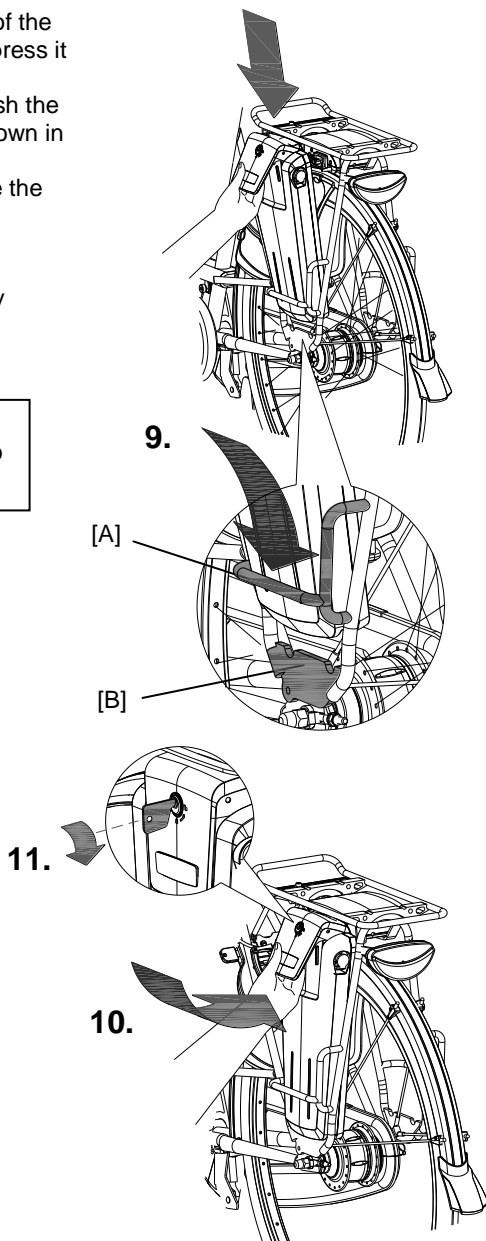



Make sure that the switch is set to the side the battery is placed.

Backup battery (optional)

The bike can be supplied with a second battery.

To activate the second battery (when the first battery is empty) turn the switch under the luggage carrier to the right side.

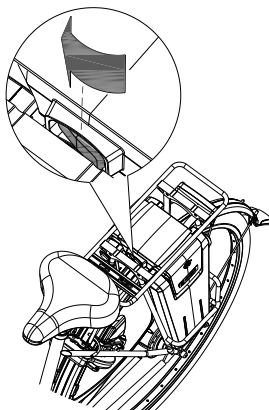

Keep in mind that your bike provides less support when it's cold (0°C and less) and the battery will discharge faster. Charging also takes more time at lower temperatures.



The action radius depends on a lot of different factors and is strongly influenced by: capacity and voltage of the battery, degree of support that is used, temperature, wind speed, tyre pressure, cycling speed, weight of the user and the luggage, use of gearing etcetera.

Charging and maintenance tips for the battery



Every battery discharges automatically over time. This process is called self-discharge. A battery that is empty and not charged, will self-discharge and will be deep discharged. The battery can be permanently damaged during this process. In case of deep discharge, the warranty will be void.

Beware:

- Never leave the bike with an empty battery! We advise you charge the battery as soon as possible before it's totally empty.
- The best storage-charge of the battery is when three to five LED lights burn.
- Check the battery every month in the winter. If fewer than three LED lights burn, recharge the battery.
- Make sure that the battery is not charged at a temperature lower than -5°C. We advise you charge the battery at room temperature.
- Only use the charger indoors and in non-humid environments, the charger may not get wet.

- Only use the Van Raam supplied battery.
- Only charge the battery with the supplied charger!
- The battery housing and charger housing may never be opened! When there is a problem, contact your dealer.
- Don't charge the battery in full sunshine.
- Don't drop the battery, this can cause external and internal damage.
- If your bicycle has a fault, the battery should be disconnected for the bicycle.



Problem solving

- The system does not turn on:
 1. Make sure that the battery is properly attached.
 2. Check the status of the battery. If it is empty, recharge the battery.
 3. Make sure the battery is active. If the battery is not used for several days it will shut itself down. The battery can be reactivated by recharging it briefly, pushing and holding down the on/off button while cycling (less than 10km/h), or on certain batteries by pushing the indicator button on the battery until the indicator appears.
 4. If the above action does not help, contact your dealer.
 - If the battery indicator LED lights on the display are flashing:
The motor may be overheated by continuous high load. For protection, the system will reduce the support.
 1. The system is in temperature-protection. You can continue cycling with reduced support.
 2. After cooling down, the normal support and indication will restore automatically.
 - If the support LED lights on the display are flashing:
This indicates motor failure. You will need to contact your dealer.
- If a red LED light on the charger starts flashing, remove the plug from the mains outlet and do not longer use the charger. In this case, contact your dealer.

Depending on your order, you can use the accessories as described below.

Dividable frame

The ramp can be disconnected from the bike, which can be convenient if, for example, you want to store the bike.

To disconnect the ramp:

1. Use the parking brake by pressing the left brake [A] and securing the brake with the pin [B].
2. Remove the grip (with the gear) from the handlebars. Push the pellet of the small spring so the grip can be removed from the handlebars.
3. Hang the grip together with the brake handle on the luggage rack or other suitable parts.
4. Lower the support. By loosen knob [A], push down support [B] with your hand or foot and then fasten the knob again.

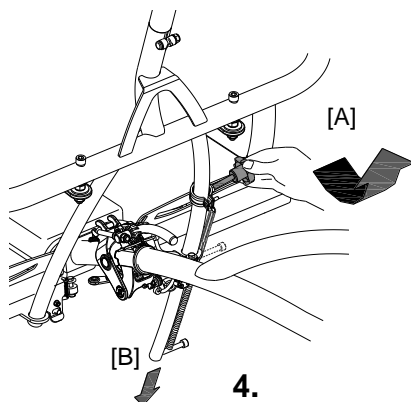
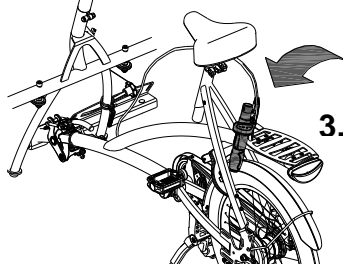
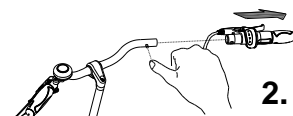
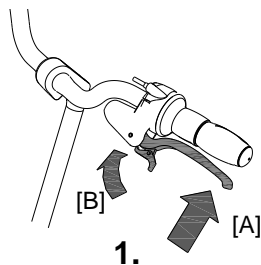

5. Remove the safety pin.
6. Pull the lever [A] up. Detach the bracket [B] and pull the lever back.
7. Remove the bike apart from the coupling.
Caution: this is heavy! Hold the frame firmly in both hands.
8. Place the bike on the stand.

To reassemble the bike, follow these steps in reverse order.

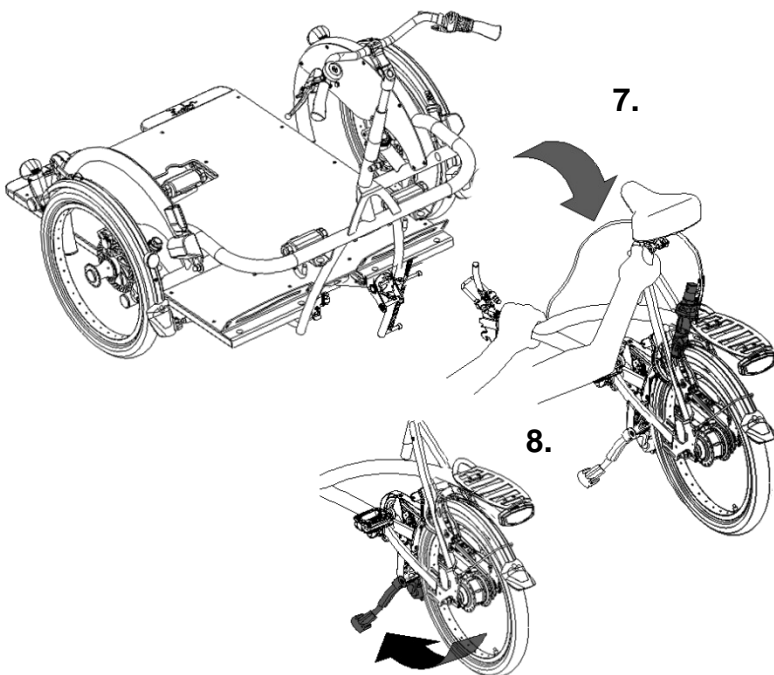
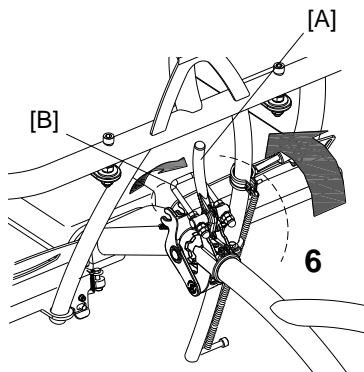
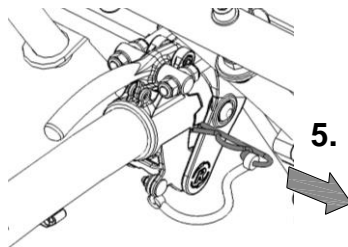

Integrated lighting control

The tricycle can be fitted with a different headlight. This lighting is connected to the electrical system.

Adjust the angle of the headlamp. Make sure that the centre of the beam is approximately ten meters in front of the bike.

The headlight switches automatically on when the electrical system is activated. You can manually activate and deactivate the lights with a short press of the on/off button on the display. If the electrical system is switched off, the lighting turns off automatically.

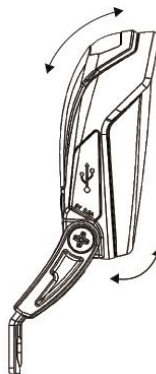

Once the battery is low, the motor will no longer provide support for cycling. The integrated lighting continues to work. However on the remaining charge.



The USB port, which is located on the headlight, has no function.

Extra accessories are available at your dealer.

Technical details

Length (cm)	240
Width (cm)	109
Height (cm)	114
Boarding height (cm)	52
Length of inner leg (cm)	82 - 96
Front wheel	20"
Back wheel	20"
Weight (kg)	Circa 62
Max. load luggage rack (kg)	20
Max. user weight (kg)	200
Brakes, front	Disc brakes
Brakes, back	Cantilever brakes

Maintenance and adjustments to be done by owner

Below you can find the instructions for maintenance and adjustments that you can do yourself on a regular basis, which will keep your tricycle in top condition.

Cleaning

The frame of the tricycle can be cleaned with a damp cloth. For areas that are dirtier you can use a mild detergent.

The wheels can be cleaned with a moist brush with plastic hairs (not a wire brush!).

The saddle and the grips can be cleaned with mild soap and water.



Do not use a pressure washer or a steam cleaner!

The right lubricant

The chain should be cleaned and maintained at regular intervals (every three months approximately). Only use special chain grease or Teflon spray. This is the only way to make sure that the chain will run smoothly, will stay water resistant and will not rust.

1. Wipe the chain with a cloth.
2. Treat it with grease or spray.
3. Remove any excess lubricant with a rag.

Other parts should **not** be treated with a lubricant.

Inspection of the tricycle

It is recommended that the tricycle has a yearly inspection carried out by the dealer to claim warranty. Please use the form "Form service, maintenance, modifications and warranty claims" in the back of this manual. After 200 kilometres or after a period of two months the tricycle should be inspected.

In the event of technical trouble or faults, the tricycle should be taken to the dealer for repairs **immediately**.

The replacing of safety-related components (especially frame, brakes, lighting, handlebars, front fork and actuation) should be performed by the dealer.

If you still decide you want to replace components yourself, you are responsible for damage or harm due to incorrectly fitted components.

Only use **original** Van Raam spare parts, which you can buy at you dealer. If requested the dealer will make the necessary information on repair and maintenance available.

Repairs and maintenance to be done by dealer

Check the brakes, the rims, lighting, the chain tension and the spokes. Also check the tyre tread depth. This should be at least one millimetre. Worn out tyres or possible faulty parts should be replaced. Also check the parking brake. With the parking brake pulled up, the tricycle should not ride away with the cyclist.

Checking the rim

Due to the combined action of the brake and the rims, not only the brake lining but also the condition of the rim is important. For this reason the rim should be checked at regular intervals, for example when you inflate the tyres. The presence of fine cracks in the spoke punches or deformation of the rim when there is higher air pressure, indicate more serious wear and tear. In that case the rim should be replaced, because it can lead to loss of brake function or even a crack in the rim, which can lead to all kinds of dangerous consequences.

Repairs, maintenance and modifications should only be performed with original Van Raam parts.

Adjustments to be done by dealer

The correct tension of the chain

The chain should not be too tight. It should hang loose. Without effort you should be able to move the chain up and down, half a centimetre approximately.

To keep the chain tension correct, the back wheel axle is adjusted. Follow the instructions below:

1. Slightly loosen the nuts of the back wheel axle, so that it can move backwards and forwards.
2. Slightly loosen the nut of the bracket, so it can also move.
3. By tightening the adjusting nuts **at both sides**, the back wheel slowly moves

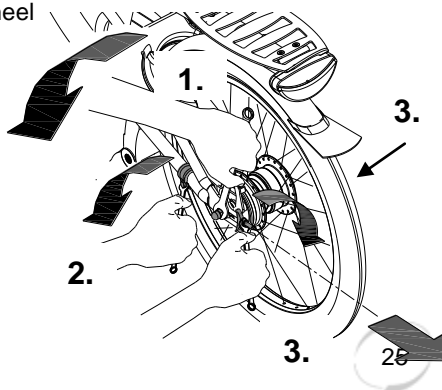

backwards. Tighten the adjusting nuts in such a way that the chain is hanging loose, as described above.

4. At the same time, make sure that the wheel is straight and positioned in the centre of the frame, as illustrated. Not to the left or to the right.
5. Slightly tighten the nuts of the back wheel axle.
6. Check whether the chain tension is correct and whether the wheel is straight and in the centre of the frame.
7. Tighten all the nuts again.

Disposal

If you want to dispose your tricycle, contact your dealer. You can also contact the local waste disposal company. They will dispose the tricycle according to the regulations of your town.

Handover/sale to a new owner

When you hand over your tricycle to a new owner it is important that you also hand over all necessary technical documentation and spare keys, so that the new owner can use the tricycle safely.

Guarantee

The guarantee is valid for all faults in the product, which are proven to be caused by material or manufacturing error.

We give a guarantee of five years on the frame and the front fork. For all accessories and other parts (except wear parts) we provide a two year guarantee, as legally regulated. The guarantee only applies by normal use and maintenance of the tricycle, as described in this manual.

Beware!

The guarantee as well as the product liability in general expires if the instructions stated in this manual are not followed. This is also the case if unauthorized maintenance is carried out or if technical changes or additions are made with non-original Van Raam parts without permission of Van Raam. The original CE certification will become nul-and-void if modifications are done by third parties. The absence of the certification can lead to problems in insuring your bike, and for any loss or incurred.

Frame number

The frame number is printed on the sticker. This sticker is located on the frame, see the image below.

Example sticker:



Position of sticker:



Form service, maintenance, modifications and guarantee claims

To maintain guarantee on the Van Raam tricycle, follow this service schedule.

Service:	Carried out (date):	Signature dealer:
Service after the first 200 KM or two months.		
Service 1 year after delivery.		
Service 2 year after delivery.		
Service 3 year after delivery.		
Service 4 year after delivery.		
Service 5 year after delivery.		

Even after five years, we advise you to give your bike annual service. Passing by the service after five years will have no further effect on guarantee claim because it expires for certain parts after five years.

Modifications to the bike

The following items are changed to the bike:

Changed:

Date:

Carried out:

Beware! Please note that if changes are made by a non-authorized Van Raam dealer or no original Van Raam parts or options are used, guarantee may void.

Delivery and service form

Congratulations on your purchase of your Van Raam tricycle. This bike is produced with utmost care. To guarantee the quality as much as possible Van Raam produces the cycles according to the ISO 9001: 2008 quality standards. Van Raam has been certified by TÜV Rheinland Netherlands BV.

You will especially enjoy your Van Raam bike when the bike is adjusted to your specifications and when the instructions in the user manual are followed. Pay special attention on the service intervals who specified in the manual of the bike.

To claim warranty and service you should always fill out this form, at least at delivery and service. This signed form declares that the end user had an instruction on the operation of the tricycle, that the tricycle is adjusted to the specifications of the end user and that the user manual is received.

Fill out when the tricycle is delivered

Type Van Raam tricycle:	
Frame number:	
Key number:	
Delivered to:	
By dealer:	
Place:	
Date:	
Signature user bike:	Signature dealer:
When available, stamp dealer:	