

User manual



O-Pair²



Van Raam BV
Aaltenseweg 56
7051 CM Varsseveld
The Netherlands 06.13

Contents

Contents	
Contact details manufacturer.....	
Conformity	
Introduction.....	
Delivery	
Intended usage.....	
Safety measures	
Delivery inspection	
Adjustment of the bicycle.....	
Accessories	
Before the first use	
Technical details.....	
Maintenance and adjustments to be done by owner	
Repairs and maintenance to be done by dealer	
Disposal.....	
Handover/sale to a new owner	
Guarantee	
Frame number.....	

Contact details manufacturer

Van Raam BV
Aaltenseweg 56
7051 CM Varsseveld
The Netherlands

Tel. : +31 (0)315 257370
E-mail : info@vanraam.nl
Internet : www.vanraam.nl

Conformity

Van Raam declares as manufacturer that the O-Pair² bicycle has been produced in accordance with the 93/42/EEG guidelines.

Introduction

This user manual gives important and necessary information about the use of your bicycle. We ask you to go through the manual thoroughly before using the bicycle.



**READ
THOROUGHLY!**

Delivery

- bicycle with possible packaging
- user manuals (s)
- pump
- foot support
- possible charger (s), depending on options

Intended usage

The bicycle is designed for normal use on level and solid ground. The usual bicycle caution should always be taken into consideration. At the same time all safety instructions as described in this manual should be complied with explicitly. Also the local traffic rules should always be complied with.

All other use, including damage or physical injuries due to this, are not the manufacturer's responsibility.

Safety measures

- Ensure the bicycle is in good condition each time before using it.
- Check before **each** ride that the brakes are in order.
- Check the lights and reflectors.
- Regularly check whether all screw joints are tight.
- Regularly check whether the wheels, the handlebars and the saddle are secure.
- Make sure there is sufficient air in the tyres.
- Only use the bicycle on a **solid and level surface**.
- Make sure that wide trousers or loose hanging clothing don't get caught in the chain, spokes or pedals.
- Do not use a pressure washer or a steam cleaner for the cleaning of the bicycle.
- Use the parking brake if you or your passenger is getting on or off the bike.
- **Never** drive without a passenger. This will cause instability of the bike and will lead to dangerous situations.

Load

The maximum load should not be exceeded. See information in the index of technical details on page 22. By permitted load we mean the total load, including the load on the luggage rack.

Make sure that the permitted load on the luggage rack is not exceeded.

Damaged or worn out parts

The replacement and repair of parts (frame, forks, illumination, brakes, drive mechanism and the handle bars) should **always** be performed by a dealer. If not, the guarantee ceases to be valid and you will be personally responsible in the event of possible damage.



Specific safety parts should **always** be replaced by new parts!

Delivery inspection

Check the delivery immediately after receiving it.

In the event of damage or incomplete delivery we ask you to contact your dealer immediately.

Adjustment of the bicycle

Before using the bicycle, adjust it to the measurements of the cyclist and the passenger. This is of great importance, especially the saddle, the handlebars and the seat.



If an optimal adjustment of the bicycle, as defined in the instructions, is not possible, you can contact your dealer for a fitting solution.

The brakes are correctly adjusted as standard and can only be adjusted by the dealer during periodic maintenance.

Saddle height

When the cyclist is sitting on the bicycle and can put a foot on the pedal in the lowest position, the saddle height is correct. Adjust the saddle height in such a way that the leg is stretched but relaxed in that position.

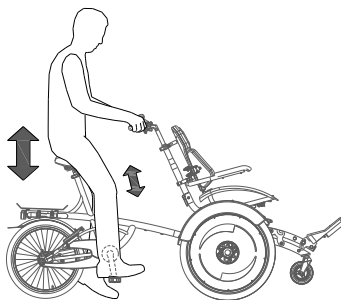

To adjust the saddle:

1. Open the quick-clamp [A].
2. Slide the saddle to the correct height.
3. Close the quick-clamp.



Make sure clothing cannot get caught in the clamp!



If the clamp closes too easily, the clamping force is too low. In this case, open the clamp and tighten the nut (B) a bit more. If a lot of force is necessary to close the clamp, the nut should be loosened slightly.

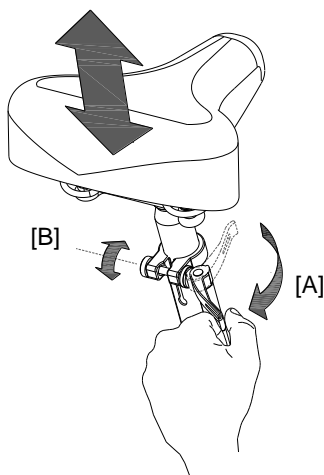

Do not pull out the saddle pin **further** than the marking. The tube will not go into the shank deep enough and will risk coming off. This can lead to serious injuries.



Handle bar height

The height of the handle bars affects the comfort of the ride. It determines the pressure on the hands and the position of the back. Determine your own most comfortable height by using the bike.

To adjust the handle bars:

1. Slightly loosen the screw by using an Allen key.
2. Slide the handle bars to the correct height and tighten the screw very firmly again.

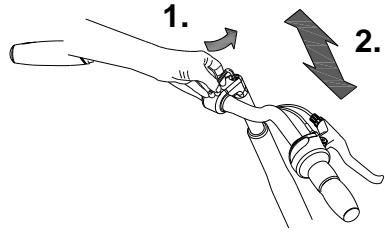

Do **not** pull out the handle bars **further** than the mark. Otherwise the tube will not be deep enough in the shaft and will risk coming off, which can lead to serious injuries.



Position handle bars

You can tilt the handle bars. This influences the distance from the handle bars to the upper body. Determine your own most comfortable position by using the bike.

To tilt the handle bars:

1. Slightly loosen the screw with an Allen key.
2. Put the handle bars in the desired position and then tighten the screw very firmly again.

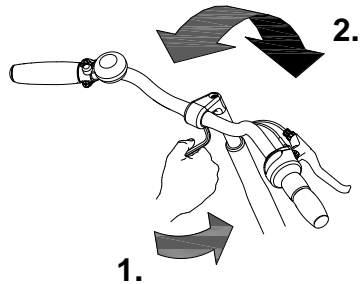

Steering damper

The steering damper affects the stability during steering. By adjusting the screw, steering gets more rigid and stability will increase. Determine your own most comfortable setting for using the bike.

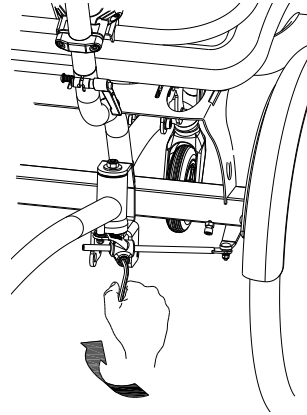

Backrest chair

Adjust the position of the backrest and the side support of the passenger.

Start with the height of the backrest and armrests. To adjust these:

1. Loosen the nut on the upper bracket slightly by using a socket wrench. Loosen the two screws of the lower bracket slightly with an Allan key.
2. Adjust the backrest. The backrest is adjusted correctly if the passenger can easily rest with the lower arms on the arm rests and the upper ones straight down. Tighten the nut and screws again.

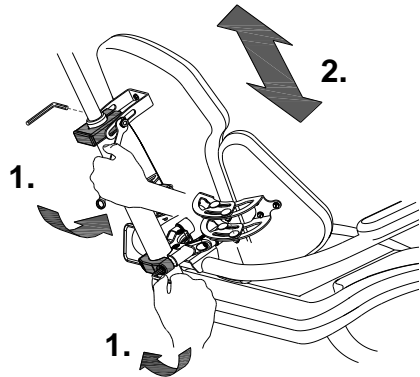

Next, adjust the backrest in the desired position. To do this:

1. Loosen the nut of the upper bracket slightly by using a socket wrench.
2. Turn the backrest, so that the passenger is sitting comfortably. Tighten the nut again.

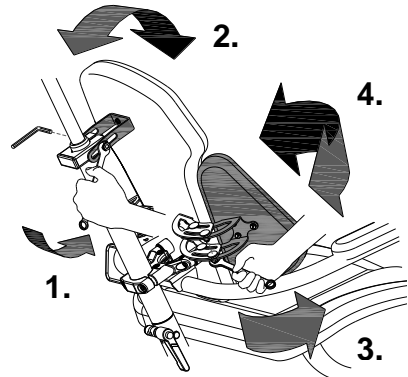

At last, adjust the side supports. To do this:

3. Loosen the four screws slightly on both sides using a socket wrench.
4. Turn the side supports to the body, in such a way that the passenger is sitting most comfortably. Tighten the screws again.

Chair foot support

Adjust the position of the passenger's foot support. To do so:

1. First determine if the foot support is in the correct location. This is depending on the length of the passenger's leg. By loosening the knob, the support can be taken out of the bracket and attached again one hole further.

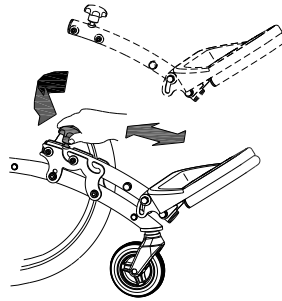

2. There is another alternative for adjustment if it is not possible for these adjustments to find the correct position. Both bracket plates can be mounted one hole to the front or one hole to the back. To do this:

Loosen the screws completely with an Allen key and move the plates to the desired position. Tighten the screws again.

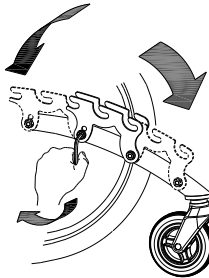

3. To adjust the position of the foot support: Slightly loosen the screw of the foot support and put the foot support in the desired position in such a way that the passenger is sitting most comfortably. Tighten the screw again.

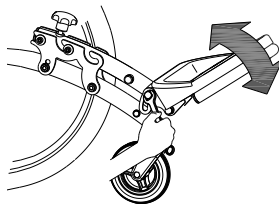

4. There is another alternative for adjustment if it is not possible for these adjustments to find the correct position. The foot support can be mounted one hole to the front or one hole to the back. To do this:

Loosen the screws completely with a socket wrench and move the foot support to the desired position. Tighten the screws again.

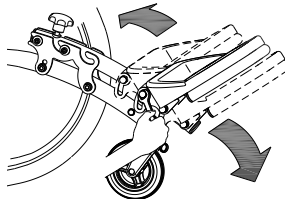

Waist belt chair

Wrap the belt around the body and buckle it.
Push the red button to unfasten the belt.

Set the belt for the passenger by:

1. Unfastening the belt.
2. Pull the belt until it fits around the body of the passenger. Then buckle it.

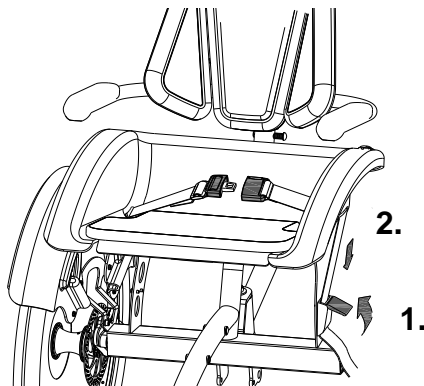

Accessories

Depending on your order, you can use the accessories as described below.

Head rest

To set the head rest:

1. Slightly loosen the nuts of the head rest with a socket wrench.
2. Position the head rest. Height, depth and angle can be adjusted at the same time. Then fasten the nuts again.

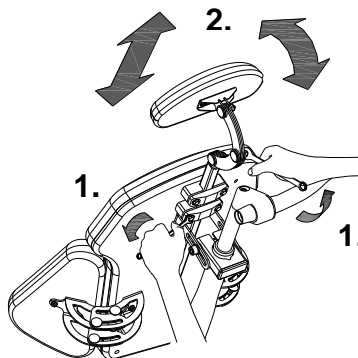

Adjust the seat depth

To adjust the seat depth of the chair to the passenger:

1. Slightly loosen both nuts with a spanner.
2. Slide the seat so it fits the legs of the passenger. Fasten the nuts again.

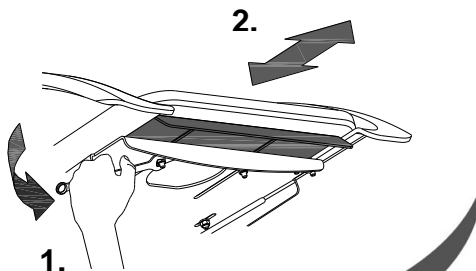

Adjust the seat width

The width of the chair can be adjusted to the passenger (A). Also adjust the supports to the front or to the back (B) so the passenger can rest comfortably on the supports. To adjust this:

1. Slightly loosen the four nuts with a socket wrench.
2. Slide the supports so they fit the body of the passenger. Then fasten the nuts again.

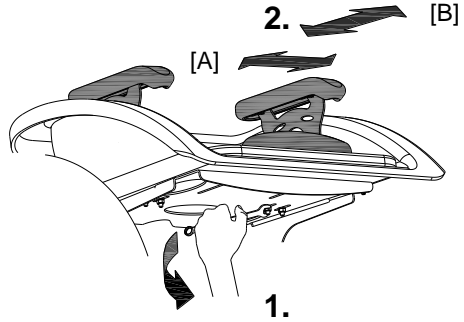

Four- and five-point belt

Wrap the belt around the body and buckle it. Push the red button to unfasten the belt again.

To use the five-point belt, one side of the waist belt is slipped through the loop of the lap belt.

Belts for children are adjusted over the side supports and then through the upholstery. For adults, the belts are adjusted over the chair.

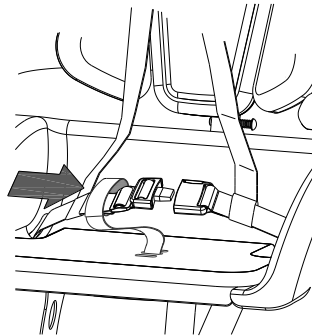

Belt for children

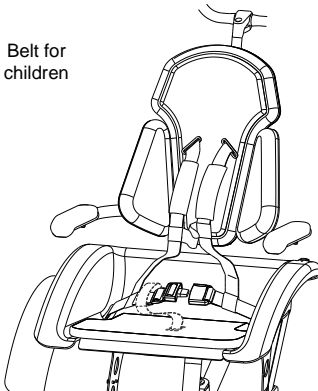

Belt for adults

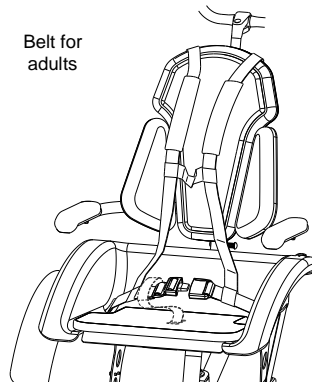

Adjust the belt to the passenger by:

1. Un-buckle the belt.
2. Tighten the belt till it fits the body of the passenger. Then buckle it.

Belt for adults

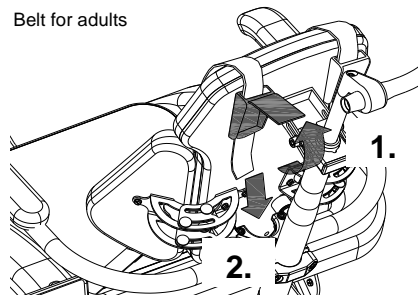

Belt for children

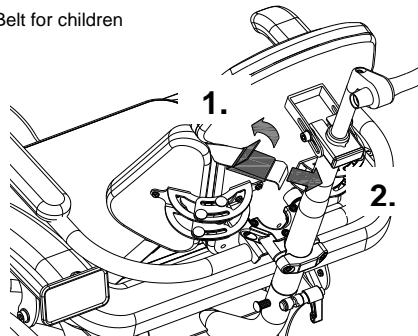

The child's belt slides through the clamp on the front side of the back, behind the upholstery. Remove the upholstery and slip the belt through the clamp.

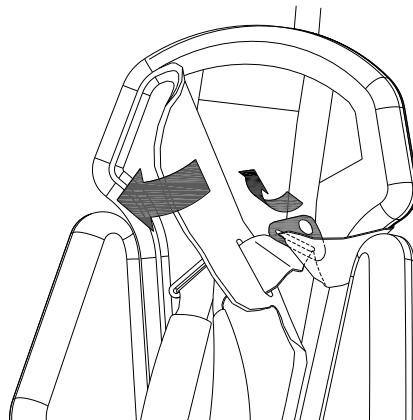

Dividable frame

The wheelchair can be separated from the bicycle part, so you can also go for a walk.

To disconnect the wheelchair:

1. Use the parking brake (A) and securing the brake with the pellet (B).
2. Remove the grip (with the gear) from the handle bars. Push the pellet of the small spring so the grip can be removed from the handle bars.
3. Hang the grip together with the brake handle on the luggage rack or other suitable parts.
4. Remove the (extra) loose grip from the holder and place it on the handle bars. Push the pellet of the small spring to slide the grip on the handle bars. Make sure the small spring is secured in the grip.
5. Lower the support wheel by pulling out the knob.
6. Remove the safety pin.

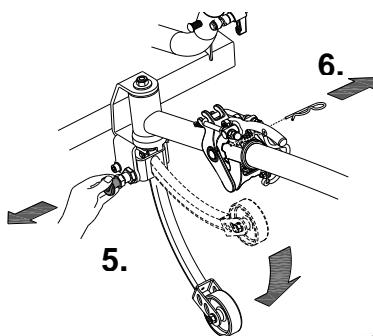
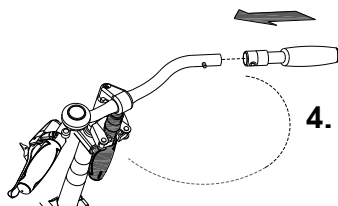
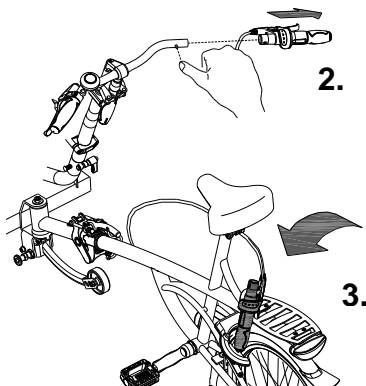
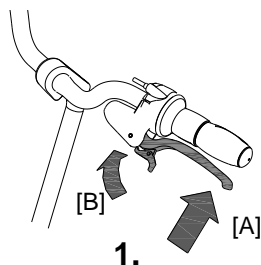

7. **Optional:** If you have an electric Heinzmann motor, loosen the cables. This need not to be done with the Silent system.
8. Lift up the handle [A]. Loosen the clamp [B] and pull back the handle again. Slowly lower the wheelchair to the front on the nose-wheel.
9. Remove the bicycle part from the coupling. **Caution:** This is heavy. Hold the frame firmly with both hands.
10. Place the rear end on the stand.

To assemble the bicycle again, follow these steps in reverse order.

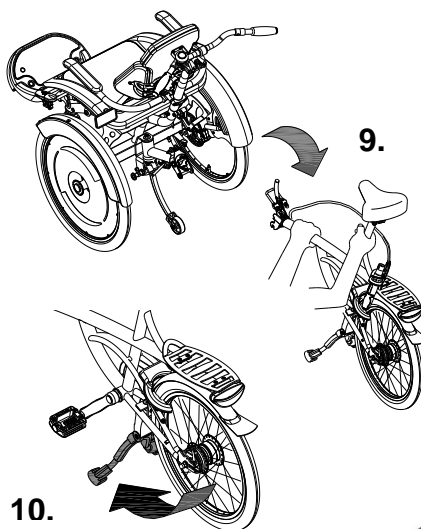
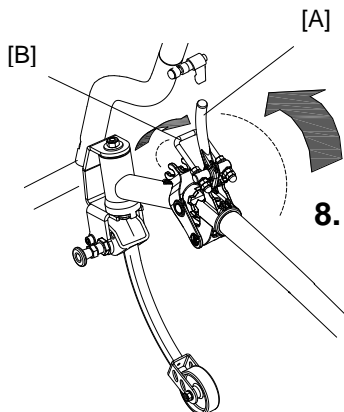
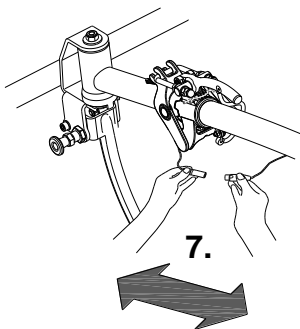

Folding the back rest

To fold the back rest:

1. Slightly loosen the fastener handle.
2. Push the pin until the handle bars are released.
3. Pull out the handlebars from the tube.
4. Now fold the back rest to the front.

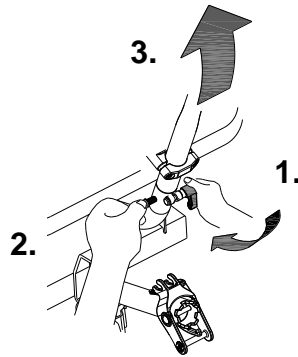

Notice that the cables are not bent when folding!

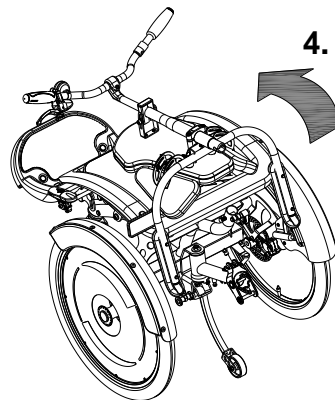

Electric motors

The O Pair can be equipped with an electric Silent motor system or Heinzmann.

Silent Electric motor

The Electric motor has the following Functions:

- Pedal assistance while cycling
- Launch control
- Backwards pedaling with assistance

Press the on/off button to turn on the motor . After the system is turned on, the electric motor is active in level 1.

Level 1 provides light support. Level 3 provides optimum support. You can change the level while cycling.

The engine has launch control. This allows the driver to accelerate without pedaling up to a speed of 5 km / h . To accelerate, press the launch button and keep it pressed down . The motor is activated after 2 seconds.

The reverse gear is activated by pedalling back from a standing position. Within a few seconds the motor is activated and the tricycle cycles at a speed of about 3KM/h backwards when you start to pedal backwards.



Do not be frightened by an unexpected noise of the electric motor. If you e.g. wait for the traffic light and you play with the pedals by moving them backwards the reverse gear is activated and the tricycle cycles backwards.

With the on/off button, you can turn off the system. When the system is not used, it will automatically turn off after a certain time.

You can see the battery level at the indication lights at the coloured display. If only the red light is on, the battery is almost empty and needs to be recharged or replaced by a new, fully charged battery.

When the last red light flashes, the battery is empty and the engine will not support you any longer while cycling.



User manual
O-Pair² 06.13

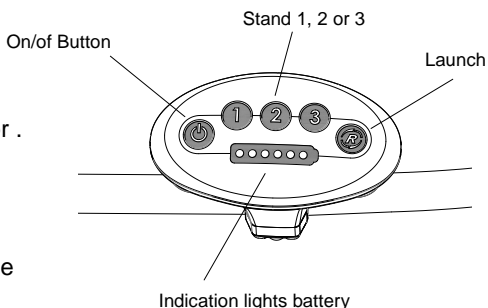

When you push the bicycle, turn off the motor.

When the motor is not used for several days, the battery switches into the sleeping mode. This to protect the batteries. To activate it, you must connect the battery to the charger for a few seconds or cycle the bike forwards and push the on/off button to activate the system.

Charging the Battery:

For the best performance and to prolong the life of the battery, we recommend that you charge the battery at home at room temperature.

To charge the battery:

- 1
Open the little lock by turning the key a quarter (to the right)
- 2
Pull the handle forward.
- 3
Take the battery pack into the house. Plug the charger into the little contact of the battery.
- 4
Connect the charger plug into the socket. The red light on the charger will light up.
- 5
Depending on the battery level, the charging time is about 3 hours. If the green light is on, the battery is charged.

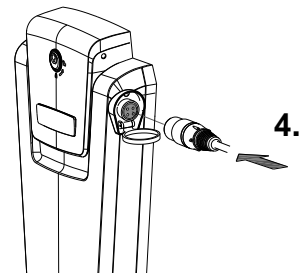
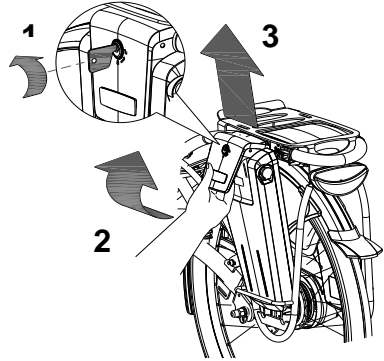

6
Once the battery is charged, pull the plug from the socket first..

7
Then pull the connector from the battery.

8
Put the battery back in the holder, behind A on B

9
Pull the handle backwards and push the battery on the top to the connector as shown in the drawing and close the lock.

10
Push the handle forward and close the lock.

It is also possible to charge the battery while it is still in the holder.

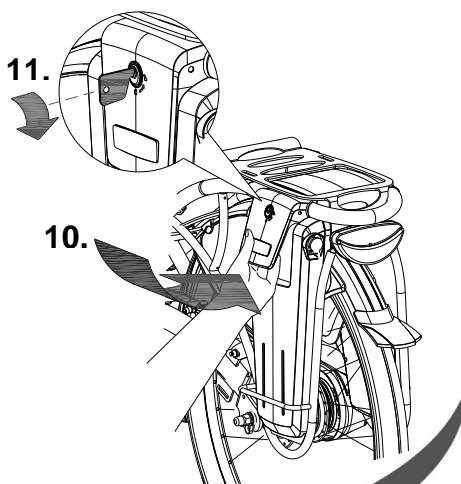
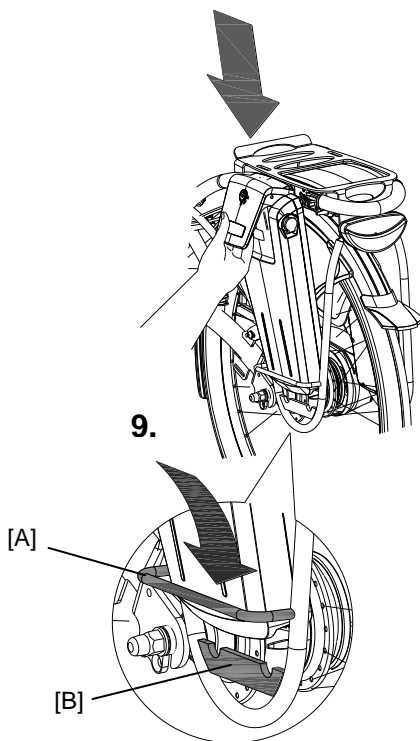



When charging the battery, first connect the charging point and then insert the plug into the socket!
After being charged, first disconnect the socket and only then remove the charger from the tricycle!



After charging, always remove the charger cable from the battery.



Ensure that the battery is always pushed straight into the holder.

Backup battery (optional)

The bike can be supplied with a second battery.

To activate the second battery (when the first battery is empty) turn on the switch under the luggage carrier in order to activate the battery.

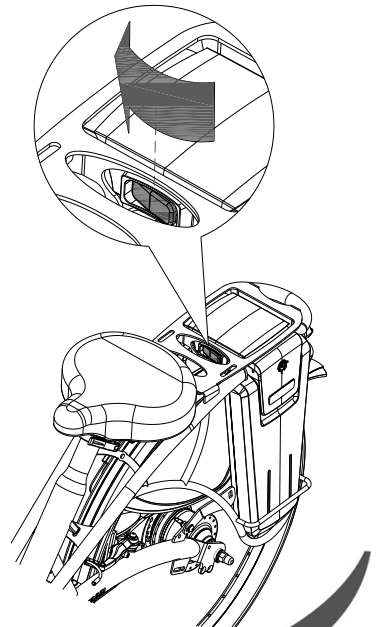

Heinzmann electric motor

The bicycle can be supplied with an electric Heinzmann motor. There are 2 types available.

Accelerator:

The electric motor is operated by using the accelerator. By using the cockpit you start the motor and determine the power of the motor. This motor accelerates and drives with a speed up to 6 km/h maximum. For more speed the cyclist has to pedal as well.

Pas-Vario:

The electric motor is operated by the cockpit. With this cockpit you switch the engine on/off and you can also determine the power of the motor. This motor only supports the cycling and does not accelerate.

Use of the cockpit (same in both types):

Press one of the buttons, 1, 2 or 3 to start the electric motor. With these buttons you can determine the power of the motor, also during cycling.

With the red button you shut down the system. If the system is not used, it will automatically shut itself down after a period of time.

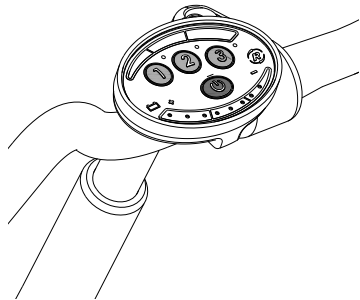

When walking backwards with the bicycle, always turn off the motor.

Charging the battery:

The charging point is situated behind the seat. To charge the battery:

1. **First** connect the charger plug to the charging point behind the seat.
2. Put the charger plug in the wall socket.
3. Depending on the state of the battery, it needs 4 to 12 hours to charge. The battery is completely charged when the green lamp lights up.
4. As soon as the battery is charged, **first** take the plug from the wall socket and then disconnect the charger from the bicycle.

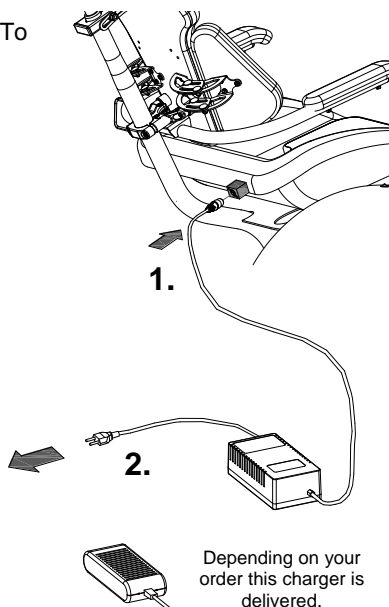

When charging, **first** connect the plug to the charging point on the bicycle and **then** put the plug in the wall socket!
When charged, **first** take the plug from the wall socket and **then** disconnect the charger from the bicycle!

The batteries can also be taken from the containers and charged somewhere else, indoors for instance. To do this:

1. Loosen the charge connector of the batteries from the charging point under the seat.
2. Undo the lock of the fastening device and open it.
3. Take the batteries from the containers.
4. Put the batteries down and connect the charge connector of the batteries to the connector of the charger.
5. Put the charger plug in the wall socket. The red light will light up.
6. Depending on the state of the battery it will take 4 to 12 hours to fully charge.
7. As soon as the battery is charged, **first** take the plug from the wall socket.
8. **Then** take the charge connector of the batteries from the connector of the charger.
9. Place the batteries back in the containers on the bicycle and lock the fastening device.
10. Then, connect the charge connector of the batteries to the connector of the charging point again.

Beware: 

- Charge the battery until the green lamp lights up.
- **Never** interrupt the charging process.
- For the lifespan of the battery it is better to charge the battery when it is almost discharged.
- It is damaging for the battery if it is not used for more than 2 months. In that case charge the battery every now and then.
- The case of the charger may not be opened by the buyer. In the event of problems go to your dealer!
- Only use the charger in non-humid indoor spaces.
- Below 5 degrees Celsius the charger will not function properly. In that case it is advisable to charge the batteries indoors.

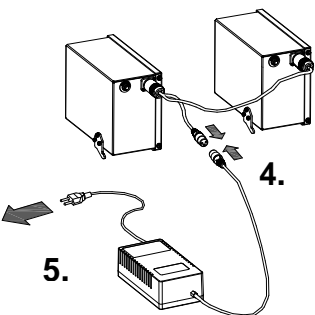
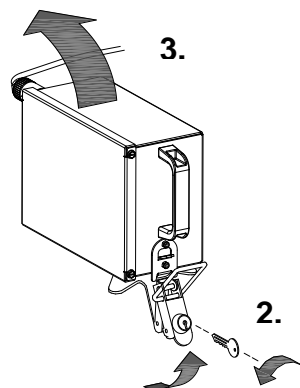
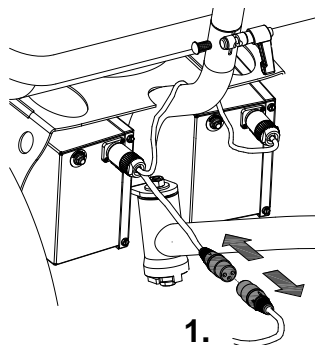

Extra accessories are available at your dealer.

Illumination

The lights work on batteries. Push the button to switch the lights on and off. Both lights have 2 modes; steady and flashing.

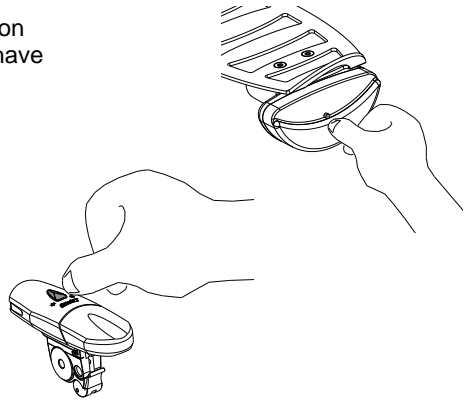

The front light has rechargeable batteries. When the light on the lamp is red, the lamp must be charged. There are two versions only batteries or with a socket.

Socket:

The lamp can be charged in the wall socket.

To do this:

1. Push the pellet and slide the lamp out of the holding device.
2. Remove the cover from the lamp.
3. Put the lamp in the wall socket. The charge light on the lamp will be on.
4. As soon as the charge light turns off, the lamp is charged. To fully charge the lamp, leave it plugged in for another 6 hours, after the charge light has expired.



For the lifespan of the batteries, we recommend charging the lamp once every 3 months, when not used for a longer period.

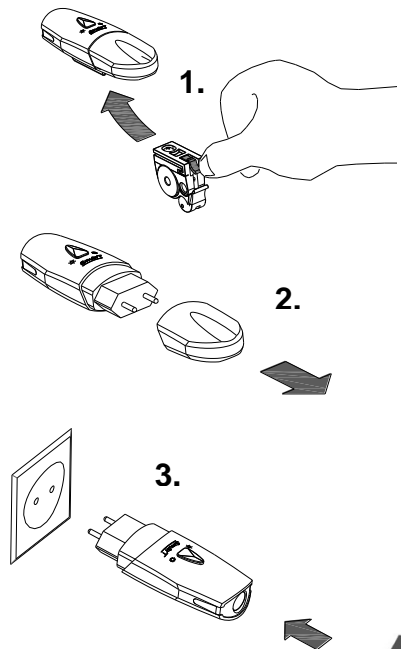

Only batteries:

Open the cover with a coin

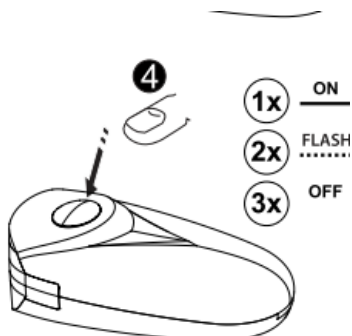
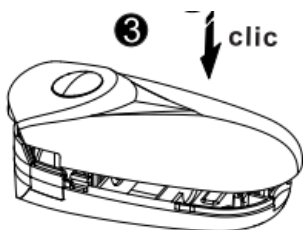
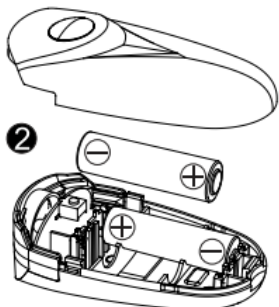
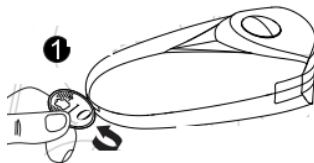

Parking brake

Always use the parking brake if you park the bicycle and leave it behind.

To operate the parking brake, squeeze the left brake [A] and lock it with the pin [B].

By squeezing the brake again it will unlock itself.

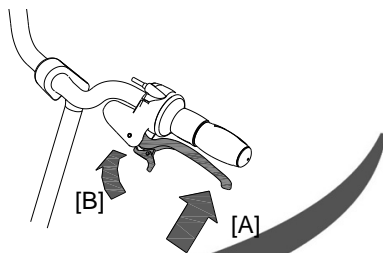

Gears

Standard the bicycle has 8 gears. The gears are used by turning the grip. **Do not use the pedals** when turning the grip.

Option: When your bike has an electric motor, there are 6 gears.

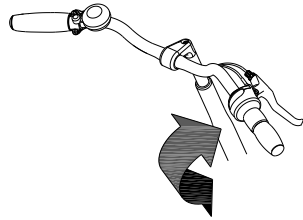

Check before every ride:

- the brakes (including the parking brakes)
- the tyre pressure
- the illumination
- that all parts are secure

Contact your dealer and do not use your bicycle if you identify any irregularities!

As with all mechanical parts, the bicycle is subject to wear and tear and high loading. If a component fails, it can lead to very dangerous situations. This can lead to damage or injuries to the user of the bicycle. Any form of tearing, scratching or changing of colour is an indication that the part should be replaced.

Points of interest during cycling

After you have adjusted the bicycle to the measurements of the cyclist and the passenger, you can start using the bike.



The tricycle gives a very different ride experience than a bicycle with two wheels!

Practice, in particular, with bends and braking, because a tricycle can react contrary to what you would expect. It may happen that the front wheel comes off the ground on the inside when going round a bend. To avoid this the rider leans towards the inside of the bend with his body.



High speeds in the bends, driving on rough ground, and sharp bends can lead to the tricycle **falling over!**

Important safety points for the cyclist

- Go very carefully during the first ride.
- When riding the bicycle hold both hands firmly on the handle bars and feet on the pedals.
- Test the riding style of the bicycle on rough ground at moderate speed. This way the cyclist learns how to react to unexpected movements of the bicycle and the handle bars during use.
- Explore how the tilting movements of the bicycle react to body posture. Tilt to the inside of the bend.
- Small obstacles should be cycled over with appropriate speed.
- Obstacles higher than 5 cm should be avoided.

Technical details

Length (cm)	197
Width (cm)	70
Boarding height (cm)	52
Front wheel	24"
Back wheel	20"
Weight (kg)	From 40
Max. load luggage rack (kg)	20
Total max. load (kg)	220
Brakes, front	Disk brakes
Brakes, back	Cantilever brakes

Maintenance and adjustments to be done by owner

Below you can find the instructions for maintenance and adjustments that you can do yourself on a regular basis, which will keep your bicycle in top condition.

Cleaning

The frame of the bicycle can be cleaned with a damp cloth. For areas that are dirtier you can use a mild detergent. The wheels can be cleaned with a damp brush with plastic hairs (not a wire brush!) The saddle, seat (except the upholstery) and the grips can be cleaned with mild soap and water.



Do not use a pressure washer or a steam cleaner!

Cleaning the upholstery of the seat

The upholstery and the back rest of the seat are removable and can be cleaned. You can wash them in the washing machine at 40°C maximum.

Inspection of the bicycle

After 200 kilometres or after a period of 2 months the bicycle should be inspected. Check the brakes, the illumination and the spokes. Also check the tyre tread depth. This should be at least 1 mm. Worn out tyres or possible faulty parts should be replaced.

Also check the parking brake. With the parking brake pulled up, the bicycle should not ride away with the cyclist.

The right lubricant

The chain should be cleaned and maintained at regular intervals (every 3 months approximately). Only use special chain grease or Teflon spray. This is the only way to make sure that the chain will run smoothly, will stay water resistant and will not rust. Wipe the chain with a cloth, treat it with grease or spray and remove any excess lubricant with a rag.

Other parts should not be treated with a lubricant.

The correct tension of the chain

The chain should not be too tight. It should hang loose. Without effort you should be able to move the chain up and down, half a centimetre approximately.

To keep the chain tension correct, the back wheel axle is adjusted. Follow the instructions below:

1. Slightly loosen the nuts of the back wheel axle, so that it can move backwards and forwards.
2. Slightly loosen the nut of the bracket, so it can also move.
3. By tightening the adjusting nuts **at both sides**, the back wheel slowly moves backwards. Tighten the adjusting nuts in such a way that the chain is hanging loose, as described above.
4. At the same time, make sure that the wheel is straight and positioned in the centre of the frame, as illustrated. Not to the left or to the right.
5. Slightly tighten the nuts of the back wheel axle.
6. Check whether the chain tension is correct and whether the wheel is straight and in the centre of the frame.
7. Tighten all the nuts again.

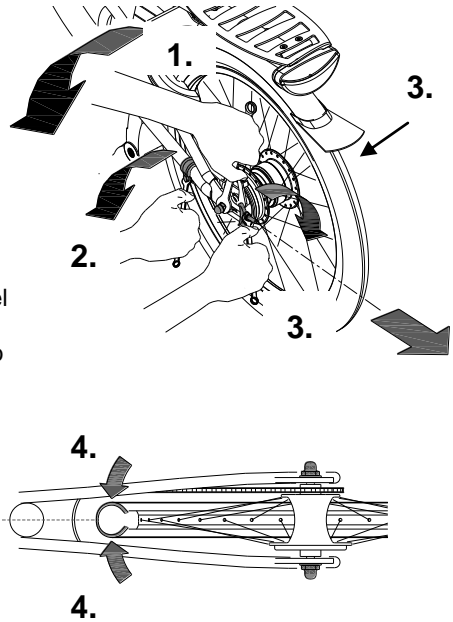

Checking the rim

Due to the combined action of the brake and the rims, not only the brake lining but also the condition of the rim is important. For this reason the rim should be checked at regular intervals, for example when you inflate the tyres. The presence of fine cracks in the spoke punches or deformation of the rim when there is higher air pressure, indicate more serious wear and tear. In that case the rim should be replaced, because it can lead to loss of brake function or even a crack in the rim, which can lead to all kinds of dangerous consequences.

Repairs and maintenance to be done by dealer

It is recommended that the bicycle has a yearly inspection carried out by the dealer. In the event of technical trouble or faults, the bicycle should be taken to the dealer for repairs **immediately**.

The replacing of safety-related components (especially frame, brakes, illumination, handle bars, front fork and actuation) should be performed by the dealer.

If you still decide you want to replace components yourself, you are responsible for damage or harm due to incorrectly fitted components.

Only use **original** spare parts, which you can buy at you dealer. If requested the dealer will make the necessary information on repair and maintenance available.

Disposal

If you want to dispose your bicycle, contact your dealer. You can also contact the local waste disposal company. They will dispose the bicycle according to the regulations of your town.

Handover/sale to a new owner

When you hand over your bicycle to a new owner it is important that you also hand over all necessary technical documentation so that the new owner can use the bicycle safely.

Guarantee

The guarantee is valid for all faults in the product, which are proven to be caused by material or manufacturing error.

For our bicycles we give a guarantee of 5 years on the frame and the front fork. For the paint, all accessories and other parts (except wear parts) we provide a 2 year guarantee, as legally regulated.

Beware!

The guarantee as well as the product liability in general expires if the instructions stated in this manual are not followed. This is also the case if unauthorized maintenance is carried out or if technical changes or additions are made without permission of Van Raam.

Frame number

The frame number is printed on the sticker. This sticker is located on the frame, see the image below.

Example sticker:



Frame number

Position of sticker:



on the back of the
saddle tube