

# User manual short



**vanraam**  
Let's all cycle



O-Pair<sup>2</sup>



Van Raam BV  
Aaltenseweg 56  
7051 CM Varsseveld  
The Netherlands

Tel. : +31 (0)315 257370  
E-mail : [info@vanraam.nl](mailto:info@vanraam.nl)  
Internet : [www.vanraam.nl](http://www.vanraam.nl)

Versie 14.10

## Saddle height

When the cyclist is sitting on the bicycle and can put a foot on the pedal in the lowest position, the saddle height is correct. Adjust the saddle height in such a way that the leg is stretched but relaxed in that position.

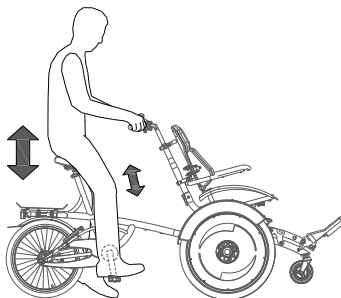

To adjust the saddle:

1. Open the quick-clamp [A].
2. Slide the saddle to the correct height.
3. Close the quick-clamp.



*Make sure clothing cannot get caught in the clamp!*



*If the clamp closes too easily, the clamping force is too low. In this case, open the clamp and tighten the nut (B) a bit more. If a lot of force is necessary to close the clamp, the nut should be loosened slightly.*

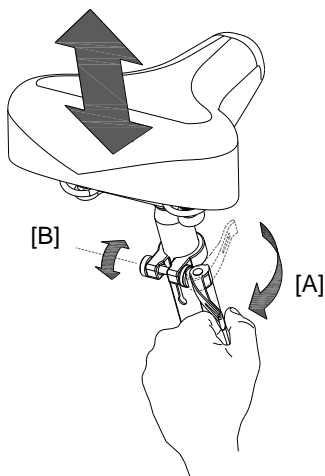

Do not pull out the saddle pin **further** than the marking. The tube will not go into the shank deep enough and will risk coming off. This can lead to serious injuries.



## Backrest chair

Adjust the position of the backrest and the side support of the passenger.

Start with the height of the backrest and armrests. To adjust these:

1. Loosen the nut on the upper bracket slightly by using a socket wrench. Loosen the two screws of the lower bracket slightly with an Allan key.
2. Adjust the backrest. The backrest is adjusted correctly if the passenger can easily rest with the lower arms on the arm rests and the upper ones straight down. Tighten the nut and screws again.

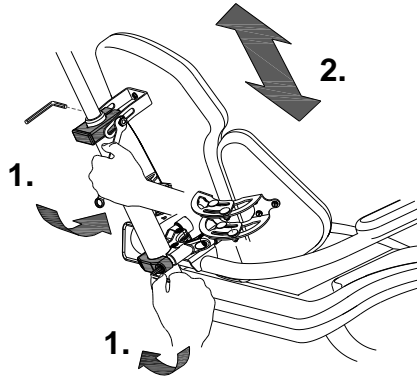

Next, adjust the backrest in the desired position. To do this:

1. Loosen the nut of the upper bracket slightly by using a socket wrench.
2. Turn the backrest, so that the passenger is sitting comfortably. Tighten the nut again.

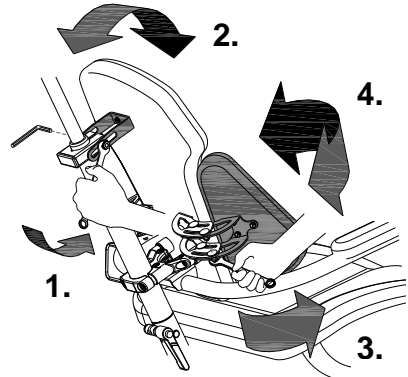

At last, adjust the side supports. To do this:

3. Loosen the four screws slightly on both sides using a socket wrench.
4. Turn the side supports to the body, in such a way that the passenger is sitting most comfortably. Tighten the screws again.

## Chair foot support

Adjust the position of the passenger's foot support. To do so:

1. First determine if the foot support is in the correct location. This is depending on the length of the passenger's leg. By loosening the knob, the support can be taken out of the bracket and attached again one hole further.

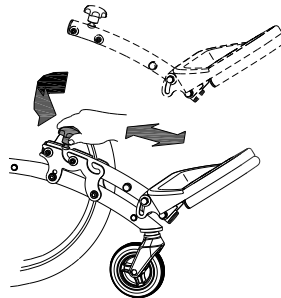

2. There is another alternative for adjustment if it is not possible for these adjustments to find the correct position. Both bracket plates can be mounted one hole to the front or one hole to the back. To do this: Loosen the screws completely with an Allen key and move the plates to the desired position. Tighten the screws again.

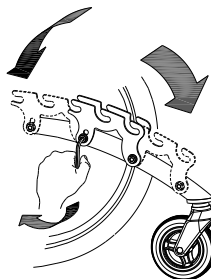

3. To adjust the position of the foot support: Slightly loosen the screw of the foot support and put the foot support in the desired position in such a way that the passenger is sitting most comfortably. Tighten the screw again.

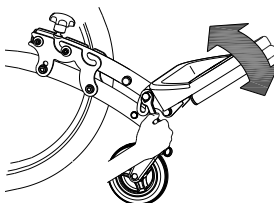

4. There is another alternative for adjustment if it is not possible for these adjustments to find the correct position. The foot support can be mounted one hole to the front or one hole to the back. To do this: Loosen the screws completely with a socket wrench and move the foot support to the desired position. Tighten the screws again.

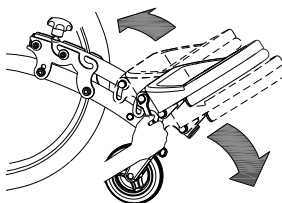

### Waist belt chair

Wrap the belt around the body and buckle it. Push the red button to unfasten the belt.

Set the belt for the passenger by:

1. Unfastening the belt.
2. Pull the belt until it fits around the body of the passenger. Then buckle it.

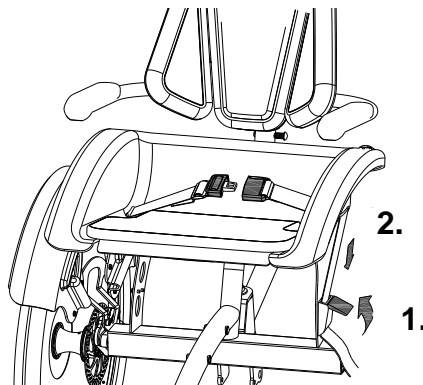

## Silent electric motorsystem

The electric motor has the following functions:

- Pedal assistance while cycling
- Start assist
- Backwards pedalling with assistance

Press the on/off button to turn on the system. After the system is turned on, the electric motor is active in level 1.

Level 1 provides light support. Level 3 provides optimum support. You can change the level while cycling.

The Silent electric motor has a start assist. This allows the driver to accelerate without pedalling up to a speed of 5 km/h. To accelerate, press the launch button and keep it pressed down. The motor is activated after 2 seconds.

The reverse mode is activated by pedalling back from a standing position. Within a few seconds the motor is activated and the tricycle cycles at a speed of about 3KM/h backwards when you start to pedal backwards.



Do not be frightened by an unexpected noise of the electric motor. If you e.g. wait for the traffic light and you play with the pedals by moving them backwards the reverse gear is activated and the tricycle cycles backwards.

With the on/off button, you can turn off the system. When the system is not used, it will automatically turn off after a certain time.

You can see the battery level at the indication lights at the coloured display. If only the red light is on, the battery is almost empty and needs to be recharged or replaced by a new, fully charged battery.

When the last red light flashes, the battery is empty and the engine will not support you any longer while cycling.



When you don't use the electric system for a couple of days, the battery will go into sleep mode. This is to protect the battery. To get the battery out of sleep mode, you should cycle for a couple of metres while pressing the on/off button on the display. At the moment the display lightens up, the battery is out of sleep mode. When you cannot cycle at this moment, for whatever reason, it's also possible to connect the charger for a couple of seconds to get the battery out of sleep mode.



When you push the bicycle, turn off the system.

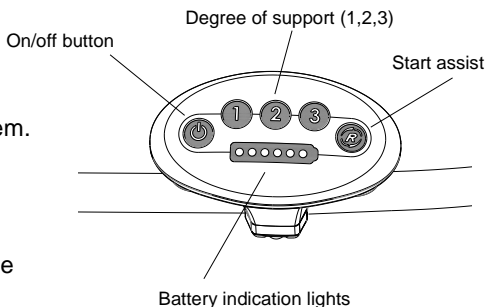

## To charge the battery:

For the best performance and to prolong the life of the battery, we recommend that you charge the battery at home at room temperature.

1. Open the little lock by turning the key a quarter (to the right).
2. Pull the handle forward.
3. Take the battery pack from the holder.
4. Take the battery inside. Plug the charger into the plug contact of the battery.
5. Connect the charger plug into the socket. Turn the switch [A] 'on'. A green LED light on the charger will start to blink fast.



**Beware!** If the battery is not connected properly, the green LED light blinks fast.

6. Depending on the battery level, the charging time is about 1,5 hour. If the green LED light stays on, the battery is fully charged.
7. Once the battery is charged, pull the plug from the socket first or turn switch [A].
8. Then pull the connector from the battery.

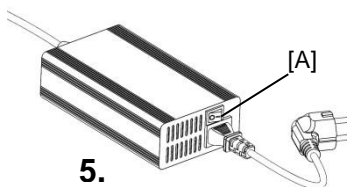
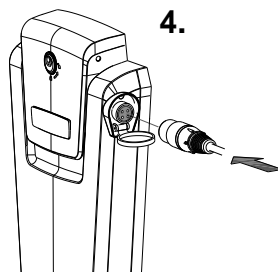
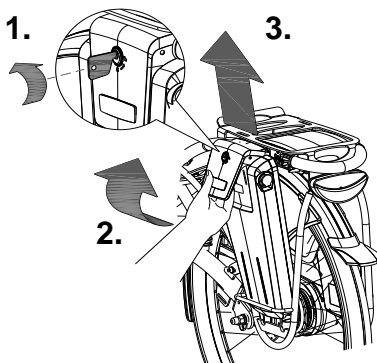

When charging the battery, **first** connect the charging point and **then** insert the plug into the socket!  
After being charged, **first** disconnect the socket and only **then** remove the charger from the tricycle!



If a red LED light on the charger starts blinking, remove the plug from the socket and don't use the charger any more. Contact your dealer.

9. Put the battery back in the holder. Slide it behind bar [A] and press it firmly on strip [B].
10. Pull the handle backwards and push the battery on the top to the connector as shown in the drawing and close the lock.
11. Push the handle forward and close the lock.

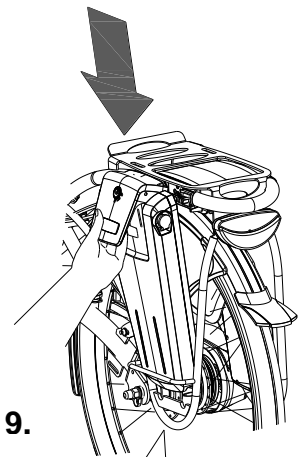

9.

It is also possible to charge the battery while it is still in the holder.

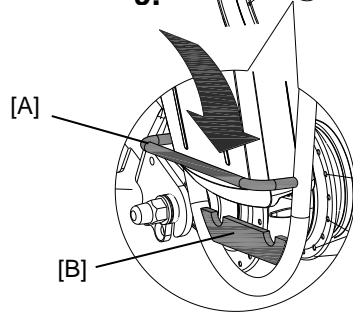

### Parking brake

Always use the parking brake if you park the bicycle and leave it behind.

To operate the parking brake, squeeze the left brake [A] and lock it with the pin [B].

By squeezing the brake again it will unlock itself.

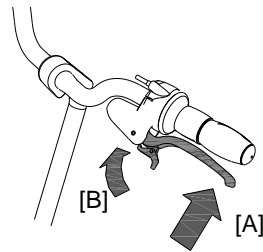

### Gears

Standard the bicycle has 8 gears. The gears are used by turning the grip. **Do not use the pedals** when turning the grip.

**Option:** When your bike has an electric motor, there are 6 gears.

