

User manual

Tricycles

Husky



Mini



Midi



Maxi



Maxi Comfort



Easy Rider Junior



Easy Rider



Easy Sport



Viktoria



Viktor



Table of content

Contact details manufacturer	1
Conformity	2
Introduction	2
Delivery.....	2
Indication	3
Intended usage.....	3
Safety measures	3
Adjustment of the tricycle	6
Before the first use	12
Electro system Silent.....	18
Van Raam e-Bike App	25
Accessories.....	26
Technical specifications	34
Maintenance and adjustments to be done by owner	35
Repairs and maintenance to be done by dealer	36
Adjustments to be done by dealer	37
Disposal.....	38
Handover/sale to a new owner.....	38
Guarantee	39
Frame number.....	40
Form service, maintenance, modifications and warranty claims.....	42

Contact details manufacturer

Van Raam
Guldenweg 23
7051 HT Varsseveld
The Netherlands

Tel. : +31 (0)315 257370
E-mail : info@vanraam.com
Internet : www.vanraam.com

Conformity

Van Raam declares as manufacturer that the tricycles, as described in this manual, are produced in accordance with the 93/42/EEG guidelines, risk category 1. All products have been produced in accordance with the 2006/42/EG guidelines. The declaration of conformity can be found on the Van Raam website.

Introduction

This user manual provides important and necessary information about the use of your tricycle. We ask you to read this manual thoroughly before using the tricycle. Always follow all the instructions given in this manual.



READ CAREFULLY

All safety and user aspects have to be made clear to children and to people with limited powers of perception by a responsible and supervising person.

Delivery

- Tricycle with packaging
- User manual(s)
- Possible chargers (depending on options)
- Spare key

Check the delivery immediately after receiving it. In case of damage or incomplete delivery we ask you to contact your dealer immediately. Upon delivery you should fill out the form "Form service, maintenance, modifications and warranty claims" in the back of this manual.

Indication

Children or adults who cannot use tricycles or vehicles due to their handicap, are able to ride these tricycles. The tricycles can be used by children or adults with neuro-muscular disorders such as paralysis of the brain and muscular dystrophy. This also applies to people suffering from co-ordination problems, loss of balance and limited natural movements. If necessary, supervision may be desirable.

Intended usage

The tricycles are designed for normal use on level and solid ground. The usual tricycle caution should always be taken into consideration. At the same time all safety instructions as described in this manual should be complied with explicitly. Also the local traffic rules should always be complied with.

The tricycles is meant for one person. The driver should be independently mobile and may not have any serious visual or other impairments, which could adversely affect the controlling of the tricycle.

All other use, including damage or physical injuries due to this, are not the manufacturer's responsibility.

Safety measures

- Ensure the tricycle is in good condition each time before using it. Check before **each** ride that the brakes are in order. Check the lighting and make sure there is enough tyre pressure.
- Regularly check if the wheels, the handlebars and the saddle are properly fixed and also whether all screw joints are tight.
- Only use the tricycle on a **solid and level surface**.
- Make sure that wide trousers or loose hanging clothing don't get caught in the chain, spokes or pedals.
- Do not use a pressure washer or a steam cleaner for the cleaning of the tricycle.
- Block the tricycle to stop it from moving when you are getting on or off the tricycle. Do this by using the parking brake and holding the tricycle.

- Always lock the tricycle when leaving it unattended.
- Make sure that no dangerous speed develops when driving downhill and entering tunnels. Brake on time and cycle at a moderate speed.
- In case of pregnancy, extra care is required owing to a higher risk of injury.
- Do not put the tricycle in direct sunlight: the temperature of some parts could reach above 41°C resulting in possible hypersensitivity of the skin.
- In case that the tricycle is equipped with the Silent electric motor system, make sure that you get used to riding with electric support. Beware when you turn on the system and make sure you don't get startled by unexpected behaviour because you turned on the electric support. Practice the reverse function! Please be careful not to switch on the reverse function of the electric motor inadvertently.



Extra attention is essential if a child is using the tricycle!

- **Never** leave a child alone with the tricycle without supervision!
- **Always** have the child wear a tricycle helmet! Make sure the helmet fits correctly!
- Have the child wear visible reflective clothing, so they are visible to other road users!
- Warn the child to ensure that no dangerous speed develops while driving downhill and entering tunnels. Brake on time.
- It is advisable to fit a flag onto the tricycle that is visible above the child.

Load

The maximum load should not be exceeded. See information in the index of technical details on page 34. By permitted load we mean the total load, including the load on the luggage rack (or in the basket).

Make sure that the permitted load on the luggage rack and in the basket is not exceeded. (**maximum** 20 kg). People may not be transported on the luggage rack or in the basket!

Be aware that a basket full of luggage can influence the steering considerably. No luggage that limits the use of the tricycle can be transported on the handlebars.

Damaged or worn out parts

The replacement and repair of parts (frame, forks, light, brakes, drive mechanism and the handlebars) should **always** be performed by an authorised dealer. If not, the guarantee ceases to be valid and you will be personally responsible in the event of possible damage.



Specific safety parts should **always** be replaced by new parts!

Adjustment of the tricycle

Before using the tricycle, adjust it to the measurements of the cyclist. This is of great importance, especially the saddle and the handlebars.



If an optimal adjustment of the tricycle, as defined in the instructions, is not possible, you can contact your dealer for a fitting solution.

The brakes are correctly adjusted and should only be adjusted by the dealer during periodic maintenance.



Take care that fingers and limbs do not get trapped while adjusting the tricycle.

Saddle height (Husky, Mini, Midi, Maxi, Maxi Comfort, Victoria, Victor)

When the cyclist is sitting on the tricycle and can put a foot on the pedal in the lowest position, the saddle height is correct. Adjust the saddle height in such a way that the leg is stretched but relaxed in that position.

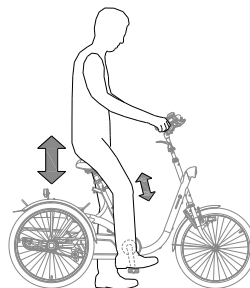

To adjust the saddle:

1. Slightly loosen the screw [A] using an Allen key.
2. Slide the saddle to the correct height.
3. Tighten the screw.

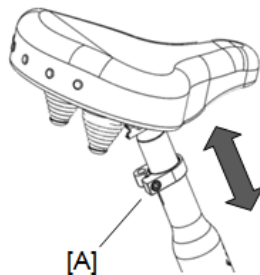

Do not pull out the saddle pin **further** than the marking. The tube will not go into the shank deep enough and will risk coming off. This can lead to serious injuries.



Saddle position (Easy Rider Junior, Easy Rider)

The saddle position is correctly adjusted when the cyclist is sitting on the tricycle and puts a foot on the pedal in the furthest position. Adjust the saddle in such a way that the leg is stretched but still relaxed.

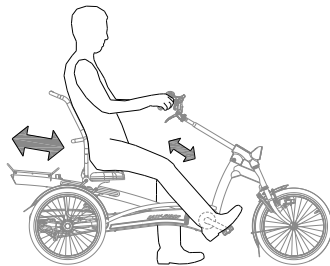

To adjust the saddle:

1. Loosen the four quick release levers slightly.
2. Slide the saddle to the correct position.
3. Tighten the four quick release levers again.



If the quick release levers are in each other's way, one can be pulled out and turned away.

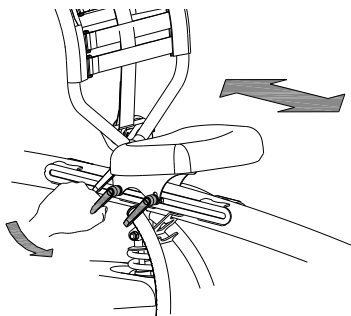

Position of the backrest (Easy Rider Junior, Easy Rider)

The backrest can be adjusted to the desired position. To do this:

1. Slightly loosen the nut [A] with a socket wrench.
2. Put the backrest in the desired position.
3. Tighten the screw again.

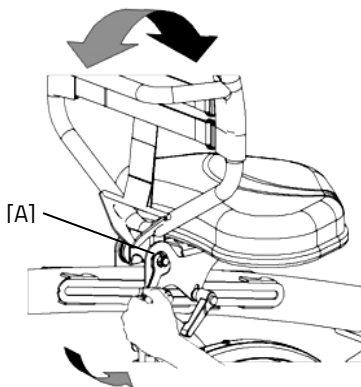

Saddle position and frame length (Easy Sport)

The saddle position is correctly adjusted if the cyclist is sitting on the tricycle and puts one foot in the furthest position. Adjust the saddle position in such a way that the leg is stretched but still relaxed.

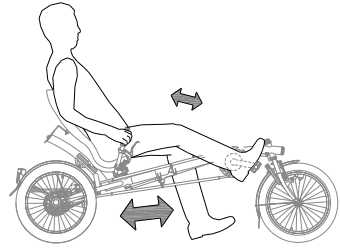

The saddle position is adjusted by shifting the frame length to the right distance.

Do this by:

1. Slightly loosen the two nuts of the frame tube [A], the two nuts of the chain brackets [B] and the nut of the handlebars tube [C] with a socket wrench.
2. Slide the frame to the correct length. Also slide the brackets [B].
3. Make sure that the handlebars are aligned with the front wheel. Then tighten the five nuts again.

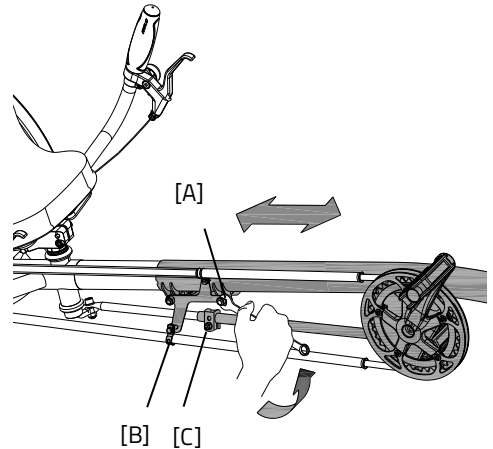

Saddle height (Easy Sport with comfortable chair)

The seat can be adjusted to the desired height. Determine which is most comfortable by using the bike.

To adjust the height:

1. Slightly loosen the four screws using an Allen key.
2. Slightly loosen the two nuts with a socket wrench.
3. Slide the seat to the desired height and then tighten the screws and the nuts again.

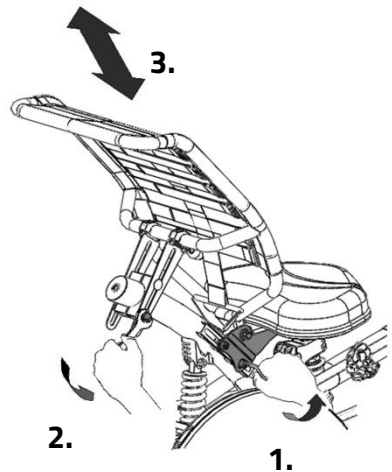

Position backrest (Easy Sport with comfortable chair)

The backrest can be adjusted to the desired position. To do this:

1. Slightly loosen the three nuts.
2. Put the backrest in the desired position and then tighten the nuts again.

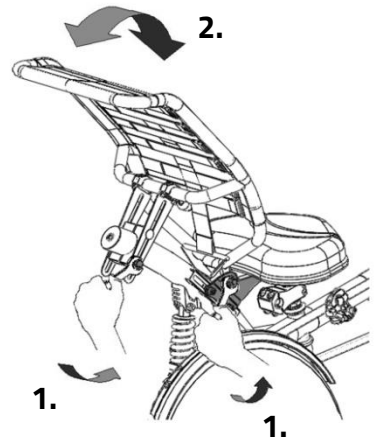

Firmness backrest (Easy Rider Junior, Easy Rider, Easy Sport)

To adjust the backrest to a looser or tighter position:

1. Open the straps by loosening the velcro.
2. Tighten the straps or loosen them.
3. Fasten the velcro again.

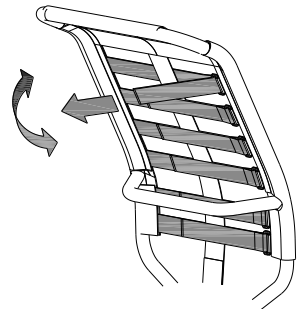

Saddle height (Easy Sport with recumbent seat)

The saddle can be adjusted to the desired height. Determine your own most comfortable height by using the bike.

To adjust the height:

1. Slightly loosen the three screws using an Allen key.
2. Slightly loosen the two nuts connected to the backrest using a socket wrench.
3. Slide the saddle to the desired height and then tighten the screws and nuts.
4. **Beware:** The bracket can be fitted in two ways. By turning the bracket the saddle can be adjusted to an extra high position.

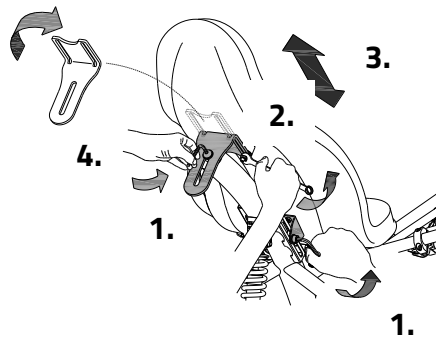

Position backrest (Easy Sport with recumbent seat)

The backrest can be adjusted in the desired position. To do this:

1. Slightly loosen the three screws with an Allen key.
2. Put the backrest in the desired position and then tighten the screws again.

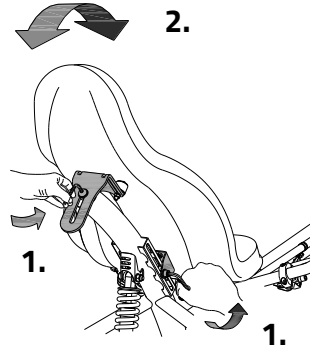

Handlebars height (Husky, Mini, Midi, Maxi, Maxi Comfort, Viktoria, Viktor, Easy Rider Junior, Easy Rider)

The height of the handlebars affects the comfort of the ride. It determines the pressure on the hands and the position of the back. Determine your own most comfortable height by using the bike.

To adjust the handlebars:

1. Slightly loosen the screw by using an Allen key.
2. Slide the handlebars to the correct height and tighten the screw very firmly again.

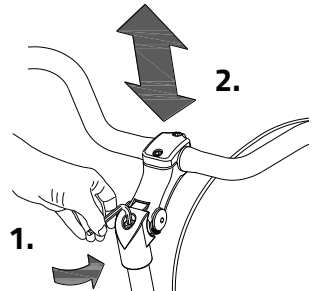

Do **not** pull out the handlebars **further** than the mark. Otherwise the tube will not be deep enough in the shaft and will risk coming off, which can lead to serious injuries.



Position handlebars (Midi, Maxi, Maxi Comfort, Viktoria, Viktor, Easy Rider Junior, Easy Rider)

You can tilt the handlebars. This influences the distance from the handlebars to the upper body. Determine your own most comfortable position by using the bike.

To tilt the handlebars:

1. Slightly loosen the screws [A] with an Allen key.
2. Put the handlebars in the desired position and then tighten the screws considerably.
3. Slightly loosen screw [B] with an Allen key, put the handlebars in the correct (horizontal) position and then tighten the screw again.

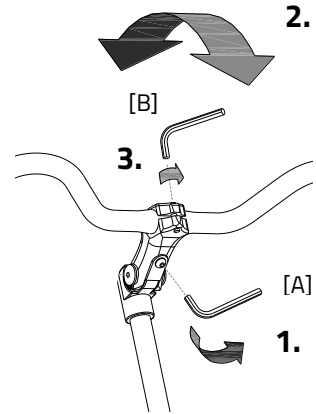

Position handlebars (Easy Sport)

You can tilt the handlebars. Determine your own most comfortable position by using the bike.

To tilt the handlebars:

1. Slightly loosen the screws with an Allen key.
2. Put the handlebars in the desired position and then tighten the screws again considerably.

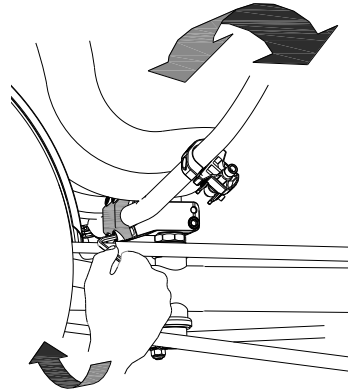

Parking brake

Always use the parking brake if you park the tricycle and leave it behind.

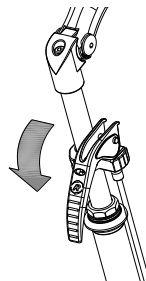

Lights

Headlight (Mini, Midi, Maxi, Maxi Comfort, Easy Rider, Easy Rider Junior, Easy Sport)

The headlight has a switch (sliding switch) with three positions: **Off-Auto-On**.

The headlight can be manually switched on or off with the "On/Off" position.

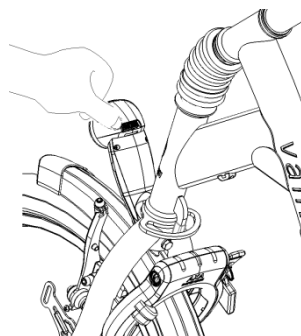

In the "Auto" position, the headlight turns on or off automatically with the help of light- and movement sensors. When the tricycle stands still for a while, the light will automatically turn off.

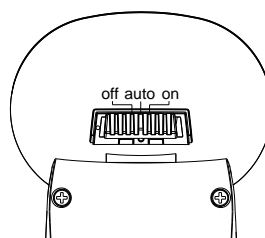

The Husky has no lighting. We recommend using the tricycle only in daylight.

Adjusting the headlight

Set the angle of the headlight such that the centre of the light beam falls approximately ten meters ahead of the bike.

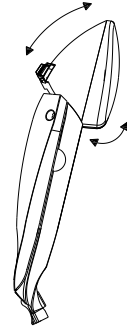

Replacing batteries

The headlight works on batteries. When the batteries are almost empty, a red LED light flashes on the headlight. Follow the next steps to replace the batteries.

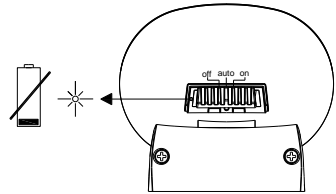

1. Remove the two screws at the back of the front light.

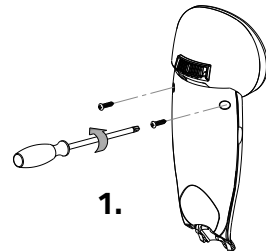

2. Dismantle the rear cover by pressing with the thumb and index finger at the cavity on both sides of the front cover and pulling the rear cover back.

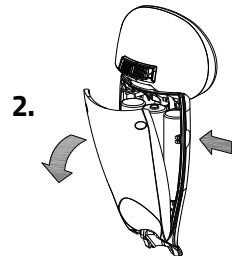

3. Replace the alkaline batteries (1.5 V - 1500 mA) and assemble the rear cover.

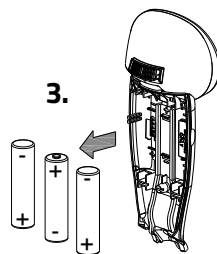

Only operate the lighting when stationary to avoid dangerous situations and the risk of personal injury. Advice: use the lighting in automatic mode.

Rear light (Mini, Midi, Maxi, Maxi Comfort, Easy Rider, Easy Rider Junior, Easy Sport)

The rear light has three options which you can choose by pressing the button repeatedly: **On-Auto-Off.**

The setting is as follows:

Press 1x: light is on

Press 2x: lighting is automatic

Press 3x: light is off

With the "On" or "Off" mode, the rear light can be manually switched on and off.

With the "Automatic" mode the rear light automatically turns on and off with the help of light and movement sensors. When the tricycle stands still for a while, the light will automatically turn off.

The rear light works on batteries. When the batteries are almost empty, a red LED light on the top starts flashing. To replace the batteries, follow the next steps.

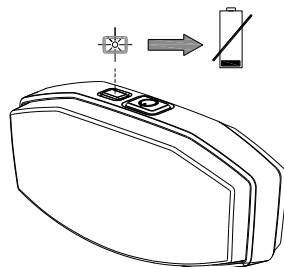
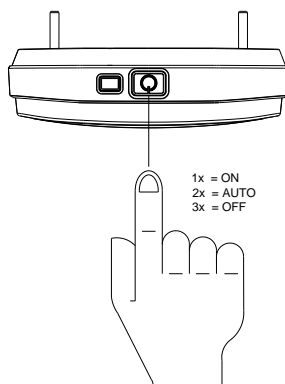

1. Dismantle the cover of the holder by pressing in the lip at the bottom of the light.

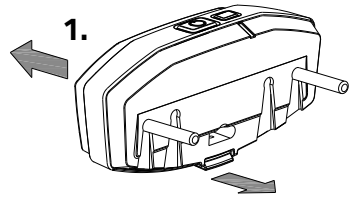

2. Replace the alkaline batteries (1,5 V - 1500 mA) and assemble the cover.

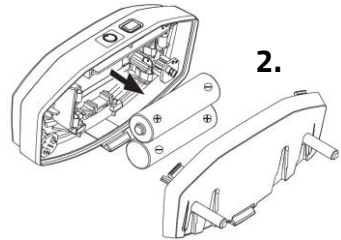

*Batteries cause environmental pollution.
Follow the local regulations during disposal.*

Gears

The tricycle has no gears or eight gears. The gear is operated by turning the grip.

Do not use the pedals when turning the grip.

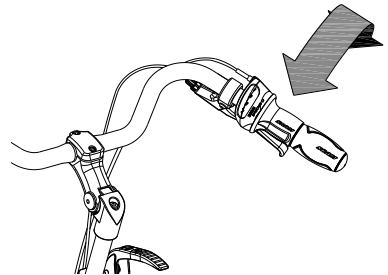

Check before every ride:

- The brakes (including the parking brakes)
- The tyre pressure (recommended: 3 bar)
- The lights
- That all parts are fitted properly
- That the battery is adequately charged (depends on options)

Contact your dealer and stop using your tricycle as soon as you observe irregularities during the check!

As with all mechanical parts, the tricycle is subject to wear tear and high loading. If a component fails, it can lead to very dangerous situations. This can lead to damage or injuries to the user of the tricycle. Any form of cracks, scratching or change in colour in heavily loaded parts or a component indicates that the component must be replaced.

Points of interest during cycling

After you have adjusted the tricycle to the measurements of the cyclist, you can start using the bike.



The tricycle gives a very different ride experience than a bicycle!

Practice, in particular, with bends and braking, because a tricycle can react contrary to what you would expect. It may happen that the back wheel comes off the ground on the inside when going round a bend. To avoid this the rider leans towards the inside of the bend with his body.

One of the brake levers (usually the right) operates the brake on the front wheel. This deserves special caution, as a forceful braking could block the front wheel, which could result in a fall. The driver should be familiar with controlled braking of the front wheel!



If there is an electric motor on a bike: you must train with the acceleration function and reverse functions. Be careful that the acceleration mode or reverse mode are not unintentionally started while using the bike. For example, at traffic lights the reverse function can accidentally be activated and the tricycle reverses.



High speeds in the bends, driving on rough ground, and sharp bends can lead to the tricycle **falling over!**



Extra attention is essential if a child is using the tricycle or a person with limited powers of perception is using the tricycle!

Before a child or an adult with limited powers of perception rides the tricycle independently for the first time, they should practice first under your supervision (or under the supervision of others).

Pay special attention to bends, because this can be a great source of danger. Also explain that the widest part of the tricycle is situated behind the driver. Let them practice passing several obstacles, to get a feel of the width of the tricycle!

Children or adults with limited powers of perception should **always** be made aware of the possible dangers of using a tricycle.

Important safety points for the cyclist

- Be very careful during the first ride.
- When riding the tricycle hold both hands firmly on the handlebars and feet on the pedals.
- Test the riding style of the tricycle on rough ground at moderate speed. This way the cyclist learns how to react to unexpected movements of the tricycle and the handlebars during use.
- Explore how the tilting movements of the tricycle react to body posture. Tilt to the inside of the bend.
- Small obstacles should be cycled over with appropriate speed.
- Obstacles higher than five centimetre should be avoided.
- Ensure that no dangerous speed develops while driving downhill and entering tunnels. Brake on time.

The Silent Electric motor system is a special developed support system by Van Raam for the rehabilitation market. The system is characterized by:

1. A simplicity of operation
2. Individually adjustable support for cycling
3. Modern and efficient electronics
4. The powerful electric motors
5. High quality and safe batteries
6. Highly reliable system

The Silent system comes standard with a basic support mode individually programmed for your bike. In most cases, it gives precise and smooth cycling characteristics with a good compromise between support and radius of action.

In special cases, an individually tailor-made cycling program is necessary. You can obtain information from the dealer about the possibilities of a customised cycling program.

Functions:

The electric system has the following functions:

- Pedal support while cycling
- Start support
- Backwards pedalling with support

1. On/off button

Using the on/off button, the electrical system can be switched on or off.

- Switching on: Push the button briefly.
- Switching off: Push the button for two seconds.

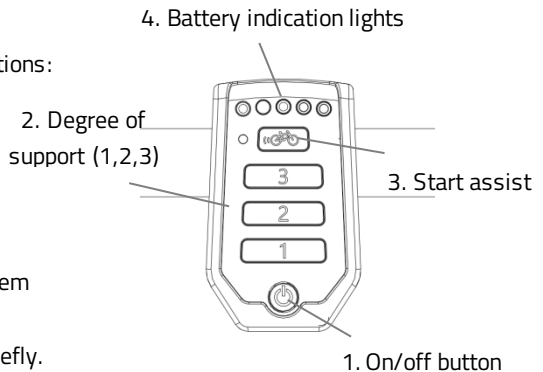

After the system is turned on, the electric motor is active in level 1.



When the system is not used, it will automatically turn off after a certain time.

With the option “integrated lighting”, the lights will automatically switch on when you turn on the electric motor system. You can switch the lights on and off by briefly pressing the on/off button in this mode.



Always turn off the electrical system when you are getting off the bicycle. Turn the electrical system on after you have taken up your riding position.

2. Degree of support 1, 2 and 3

The desired support can be set by using one of the support levels 1, 2 or 3.

1. Light support, maximum range.
2. Average support, average range.
3. Maximum support, low range.

You can change the level while cycling.

3. Start assist

The Silent electric motor has a start support. This allows the driver to pull-away without pedalling up to a speed of 6 km/h over five seconds. To accelerate, press the start assist button and keep it pressed down. The function will only activate again, when the support button has been pressed down again.

If you peddle normally, the function works for up to five seconds, each time the button is pressed, up to maximum speed of the bicycle (20–25 km/h).

The start assist is used for:

- Extra support when starting.
- Extra support for cycling uphill.



Tip: when cycling a steep climb, you can use support in level 3 and push the start assist repeatedly for five seconds to achieve maximum support.

4. Battery indication lights

The level of charge in the battery is given by five LED lights: four of these are green, the one on the left can show either green or red, if charge is low.



The battery is fully charged. When in use, the number of green LED lights on the battery will decrease.



The battery is 50% charged when two green LED lights are on.



The battery is almost empty if only the last red LED light is on. The battery needs to be recharged or replaced by a (new) fully charged battery.



When the last red LED light flashes, the battery is empty and the motor will no longer support while cycling. The integrated lighting continues to work.



Never leave the bicycle with an empty battery!
Note: charge the battery within one day.



If you push the bicycle, turn off the motor.

If your battery is equipped with a button and indicator lights, the charge-level in the battery can be checked by pressing the button briefly. The five green lights indicate the level of charge in your battery, the left one of these, if flashing, given the lowest level. While charging the battery, these lights will also indicate how far the charging has progressed.

Reverse mode

The reverse mode is activated by pedalling backwards from a standing position. Within a few seconds the motor is activated and the tricycle cycles at a speed of about 2 km/h backwards (when you start to pedal backwards).



Do not be startled by an unexpected reaction from the electrical system. If you e.g. wait for the traffic light and you play with the pedals by moving them backwards the reverse mode is activated and the tricycle cycles backwards.

Other functions

The smart display has an automatic dimming function. With an inbuilt light sensor the lights of the display will automatically create less distraction for the cyclist in darker or more shadowy conditions.

Charging the Battery

For the best performance and to prolong the life of the battery, we recommend that you charge the battery at home at room temperature.

To charge the battery:

1. Unlock the battery by turning the key a quarter.
2. Push down the lock while pulling the battery with your other hand.
3. Take the battery pack inside. **First** connect the charger to the plug-ensure contact of the battery. The magnetic plug of the charger directly connected properly to the battery.
4. **Then** connect the charger plug into the mains socket. Turn the switch [A] on. A green LED light on the charger will start to blink fast. Now the battery will recharge.



Beware! If the battery is not connected properly, the green LED light blinks slowly. In case of a poor contact, the connector of the charger needs to be cleaned.

5. Depending on the battery level, the charging time is about 2,5 hours for a battery of 11,2 Ah and 6 hours for a battery of 24,8 Ah.
6. Once the battery is fully charged, the green LED light stays on. **First** pull the plug from the mains socket or turn the switch [A] off.
7. **Then** pull the connector from the battery.
8. Put the battery back in the holder of the cycle and close the lock.

If necessary, the battery can also be charged directly on the cycle.

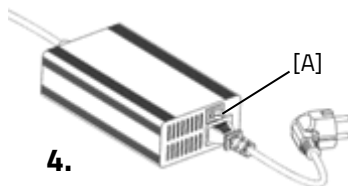
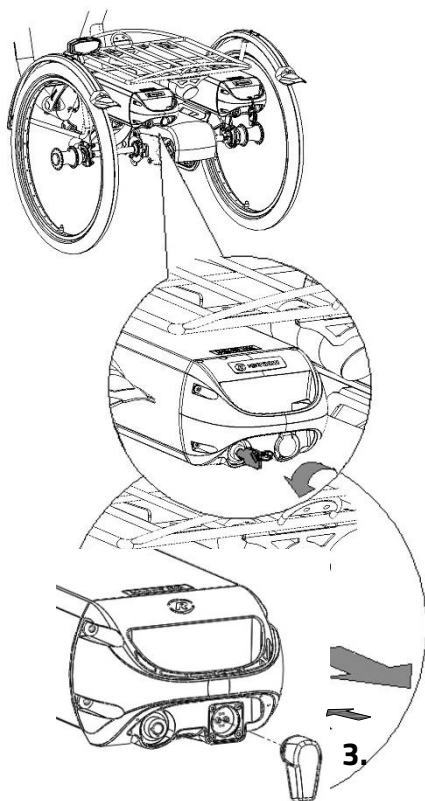



Do not wait until the battery is completely empty. It is better to top-up the battery regularly.



Ensure that the battery is always pushed straight into the holder.

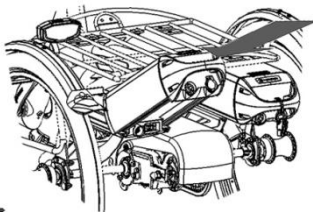
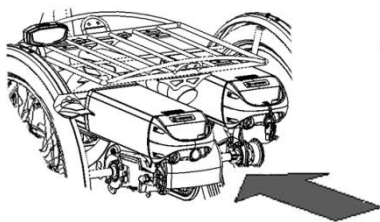

Backup battery: (optional)

The bike can be supplied with a second battery. When the first connected battery is empty, switch over to the second battery.

One of the battery holders is connected to the system, you can recognize this one because of the cables.

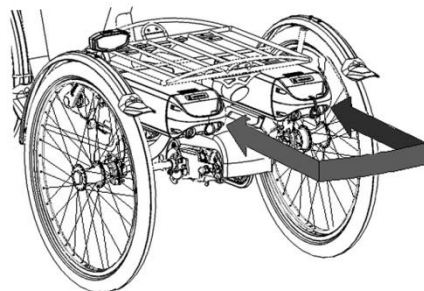

Switchable battery pack: (optional)

The bicycle may be fitted with a switchable battery pack. Once the connected battery is empty, you can swap the battery using a switch. This switch is located either under the seat, below the luggage rack or below one of the two batteries.

One of the battery holders is connected to the system, you can recognize this one because of the cables.

If desired, you can leave the second battery to charge when you are using the other.



Keep in mind that your bike provides less support when it's cold (0°C and less) and the battery will discharge faster. Charging also takes more time at lower temperatures.



The action radius depends on a lot of different factors and is strongly influenced by: capacity and voltage of the battery, degree of support that is used, temperature, wind speed, tyre pressure, cycling speed, weight of the user and the luggage, use of gearing etcetera.

Charging and maintenance tips for the battery



Every battery discharges automatically over time. This process is called self-discharge. A battery that is empty and not charged, will self-discharge and will be deep discharged. The battery can be permanently damaged during this process. In case of deep discharge, the warranty will be void.



Please note that any battery will wear over time. The wearing process of the battery is inevitable and depends on several factors, such as usage, number of charge cycles and the ambient temperature. Even if the battery is not used, its capacity will decrease. A worn battery can still be used, but please bear in mind that its charge level may decrease.

Beware:

- Never leave the bike with an empty battery! We advise you charge the battery as soon as possible before it's totally empty.
- The best storage-charge of the battery is when three to five LED lights burn.
- Check the battery every month in the winter. If fewer than three LED lights burn, recharge the battery.
- Preferably store and use the battery in environments of 5 to 20 degrees. Avoid higher or lower temperatures.
- Do not charge the battery in sunlight and make sure that the battery is not charged at a temperature of less than 5 degrees.

- Only use the charger indoors and in non-humid environments, the charger may *not* get wet.
- Only use the Van Raam supplied battery.
- Only charge the battery with the supplied charger!
- The battery housing and charger housing may never be opened! When there is a problem, contact your dealer.
- Don't drop the battery, this can cause external and internal damage.
- If your bicycle has a fault, the battery should be disconnected for the bicycle.



Problem solving

- The system does not turn on:
 1. Make sure that the battery is properly attached.
 2. Check the status of the battery. If it is empty, recharge the battery.
 3. If the above action does not help, contact your dealer.
- If the battery indicator LED lights on the display are flashing:
The motor may be overheated by continuous high load. For protection, the system will reduce the support.
 1. The system is in temperature-protection. You can continue cycling with reduced support.
 2. After cooling down, the normal support and indication will restore automatically.
- If the support LED lights on the display are flashing:
This indicates motor failure. You will need to contact your dealer.
- If a red LED light on the charger starts flashing, remove the plug from the mains outlet and do not longer use the charger. In this case, contact your dealer.

Van Raam e-Bike App

The Van Raam bicycle App is a free smartphone application that you can use while cycling with your Van Raam electric bicycle.

You can connect the Smart Display with the Van Raam App due Bluetooth connection. When it's ready to connect with your smartphone, the on/off button turn blue for a second.

The Van Raam dashboard application can be used as a luxurious bike computer while cycling with one of Van Raam's bicycles. The dashboard of the app displays the current speed, total distance, kilometrage, battery capacity and power consumption. For more cycling data, there is a detailed screen that displays, among other, the average speed, maximum speed, total distance, electricity, battery voltage, pedal power and pedal frequency.

Moreover, the Van Raam app includes a function that allows to change the pedal assistance of the electric motor to the 1st, 2nd or 3rd level. This can be selected under "programs".

In addition, you can send a SOS message in form of a text message containing your GPS location.

Now free download from the Google Play Store or Apple App store, the Van Raam eBike app.

More information about the Van Raam application can be found on the Van Raam website: www.vanraam.com.

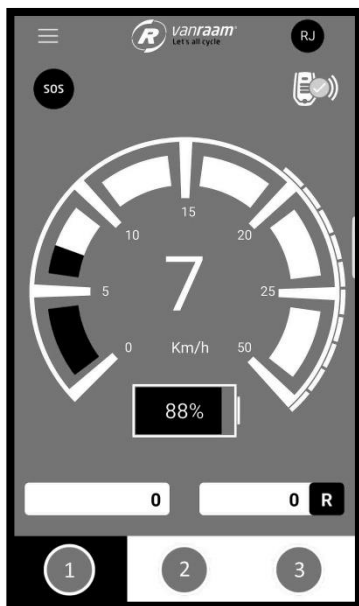

Depending on your order, you can use the accessories as described below. Extra accessories are available at your dealer.

Push bar (Husky, Mini, Midi)

To fit the push bar:

1. Loosen the screw by using an Allen key.
2. Slide the push bar in the tube up to the stop.
Then tighten the screw again very firmly by using the Allen key.

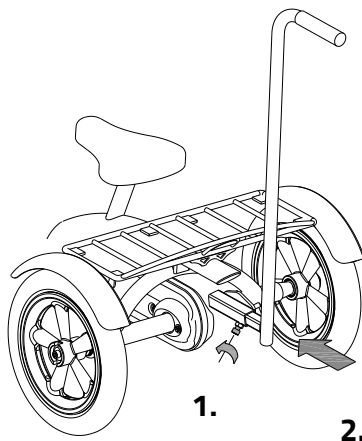

Crank shortener

The crank shortener is fitted to the crank, as illustrated. The pedal can then be fitted into the crank shortener at two positions.

With the screw [A] the crank shortener should be aligned with the crank.

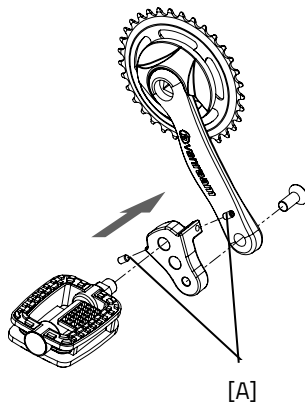

Eccentric crank

The tricycle can be fitted with an eccentric crank on the left and/or right side. The illustration may differ from your crank, because it is custom made.

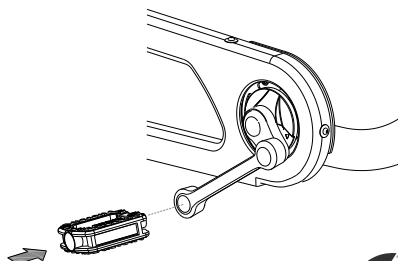

Foot support

When using the foot support you can fix your foot by sliding the two straps [A] in the quick releases [B].

The quick release can be unlocked by pulling the lip to the rear. Now the strap can be pulled out.

You can cut the straps to size. The strap should retain a length of at least five centimetre.

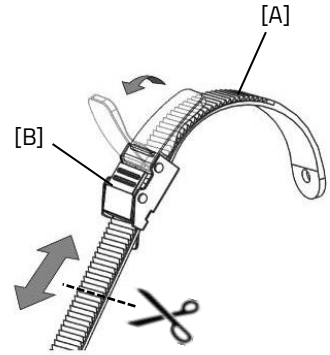

The position of the foot support on the pedal is adjustable in length. This allows you to pedal with the ball of your foot for better thrust.

1. Slightly loosen the four nuts with a socket wrench.
2. Slide the plate included the foot support forwards or backwards into the desired position. Then tighten the nuts again.

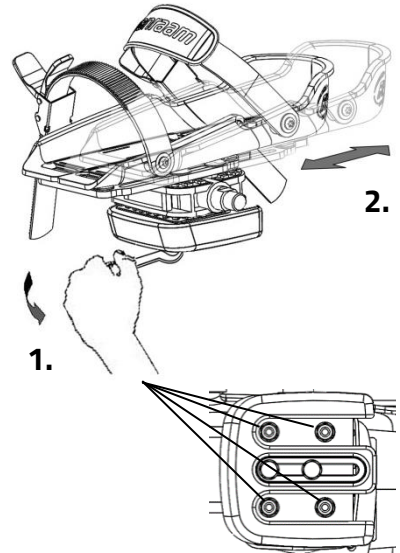

The foot support is also adjustable in width. Only the outer half of the foot support can be extended.

1. Slightly loosen the two screws with an Allen key.
2. Slide the adjustable half of the foot support to the desired position. Then tighten the screws again.

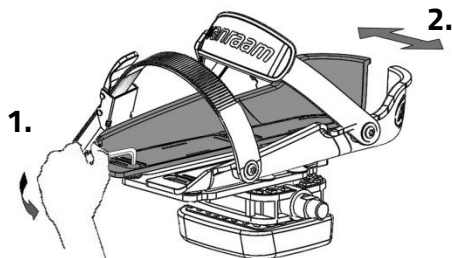

With the axel pedal extender the foot support can be extend further.



De foot support Fix20 is suitable for a foot of up to size 36. The foot support Fix 25 is suitable for size 36 to size 48.

The foot support returns to its neutral position when it is not used. The neutral position can be altered by shifting the balancing block.

1. Slightly loosen the two screws with a socket wrench.
2. Slide the balancing block to the desired position. Then tighten the screws again.

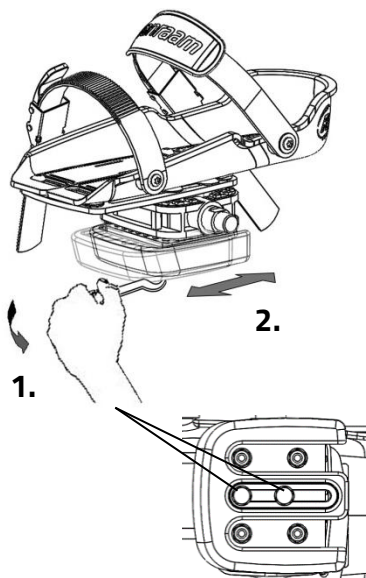

Lower leg support

The balance block can no longer be used in combination with this option. To assemble the lower leg support:

1. First attach the lower leg support to the metal plate [A]. The lower leg support is attached to the inner side of the foot support.

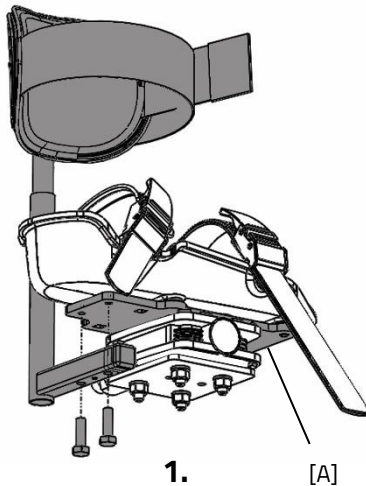

The image at the top shows Fix 20 with lower leg support, the image below shows Fix 25 with lower leg support.

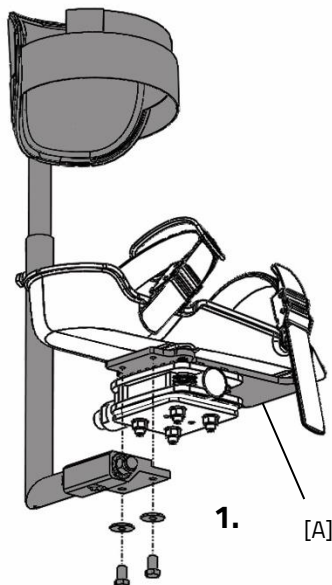

2. Adjust the height of the lower leg support in such a way that it is aligned with the lower leg of the rider.
3. The angle of the concave support is also adjustable. Rotate the concave support to the desired position.
4. Fix the elastic on the frame, so the lower leg support stays upright in its rest position.
5. Use the velcro to secure the lower leg of the rider.

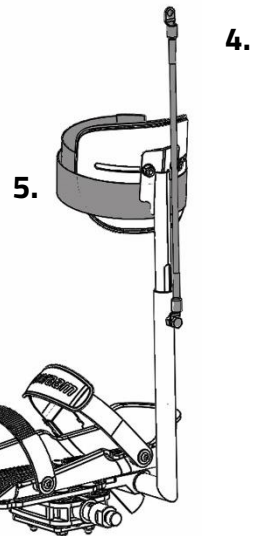
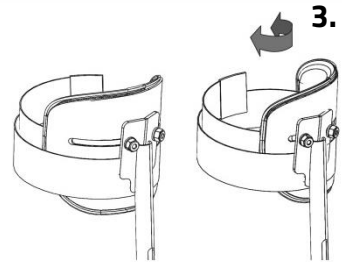
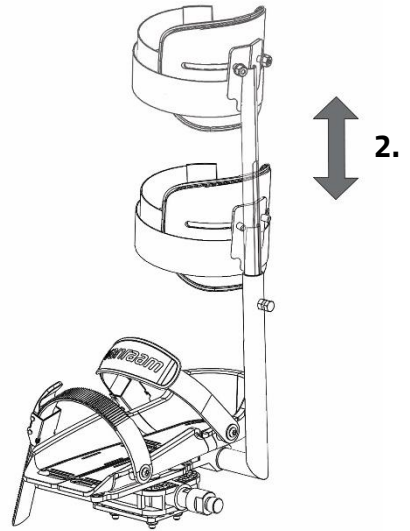

Dividable frame

The tricycle can be divided into two parts.

To divide the frame:

1. Use the parking brake.
2. Remove the grip from the handlebars. Push the pellets of the small spring [A] so that the grip can be removed from the handlebars.
3. Loosen the knob.
4. Remove the front part out of the coupling.

To assemble the tricycle again, follow these steps in reverse order.

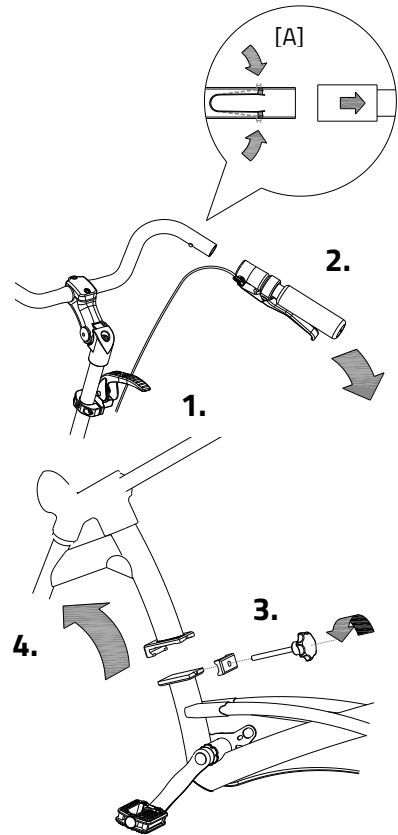

Walking-stick holder

You can take two walking-sticks with you in the stick holder. Place the walking-stick in the holder at the bottom side [A] and then secure the stick in the fastening device [B] at the top side. Always fasten the walking-stick(s) with the Velcro band.

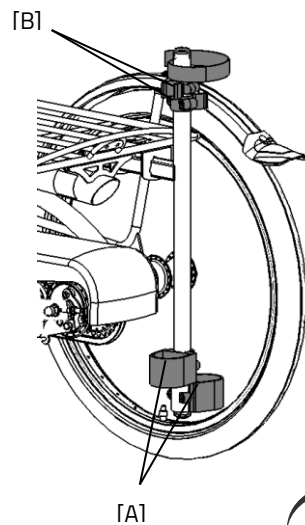

Back support

Fit the back support under the saddle with the hexagon socket [A].

First adjust the right depth, by loosening four nuts [B], putting the back support in the right position and then tighten the nuts again.

Then adjust the right height by loosening the two nuts [C], sliding the support in the correct position and then tighten the nuts again.

The back support can be fitted with a belt [D]. Use the fastening device to open and close the belt.

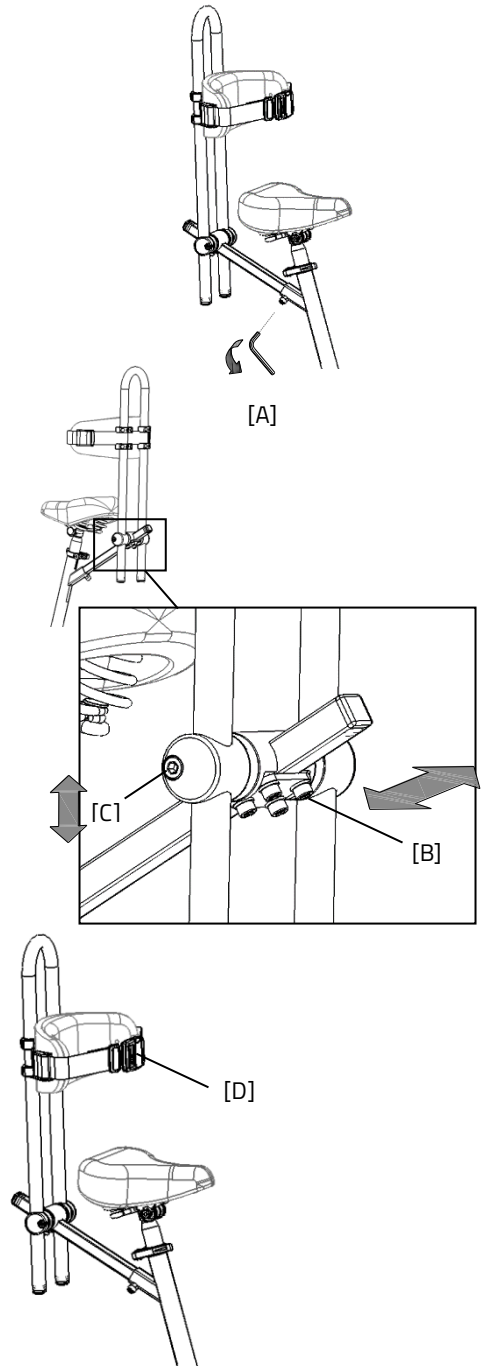

Intergrated lighting contol

The tricycle can be fitted with a different headlight. This lighting is connected to the electrical system.

Adjust the angle of the headlamp. Make sure that the centre of the beam is approximately ten meters in front of the bike.



The headlight switches automatically on when the electrical system is activated. You can manually activate and deactivate the lights with a short press of the on/off button on the display. If the electrical system is switched off, the lighting turns off automatically.

Once the battery is low, the motor will no longer provide support for cycling. The integrated lighting continues to work. However on the remaining charge.



The USB port, which is located on the headlight, has no function.

Flashing light system

To use the flashing lights press the switch [A] to the left or right.

To turn off the indicators, move the switch to the centre position.

The lights work on a battery.

To replace the batteries, turn the screw on the cap and take the orange cap [B] away. Then remove the PCB [C] from the holder. You can now replace the battery [D].

This is a 3-volt lithium battery, CR123A.



Batteries cause environmental pollution. Follow the local regulations during disposal.

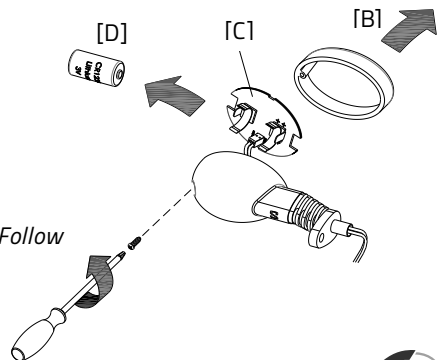
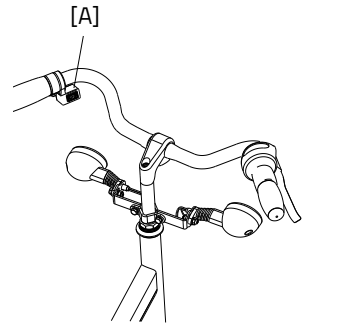

Technical specifications

	Husky2	Mini3	Midi2	Maxi2	Maxi Comfort
Length of inner leg (cm)	35-47	47-59	66-80	80-95	67-82, 76-91¹, 85-100
Frame height (cm)	23	30	41	53	42, 51¹, 60
Length (cm)	98	136	168	180	194
Width (cm)	59	60	75	75	75
Height (cm)	68	88	108	124	118
Weight (kg)	appr. 11	appr.. 21	appr. 27	appr. 29	appr. 32
Boarding height(cm)	12	20	25	28	23
Front wheel	12.5"	16"	20"	22"	24"
Back wheel	12.5"	16"	22"	24"	24"
Max. load luggage rack/ basket (kg)	20	20	20	20	20
Max. weight user (kg)	65	65	90	120	120
Brakes, front	V brake	V brake	V brake	V brake	V brake
Brakes, back	Non or V brake	V brake or Back pedal brake	V brake or Back pedal brake	V brake or Back pedal brake	V brake or Back pedal brake

	Easy Rider Junior	Easy Rider2	Easy Sport	Viktoria	Viktor
Length of inner leg (cm)	47-73	69-95	65-105	63-81	80-96
Frame height (cm)	-	-	-	41	50
Length (cm)	175	210	195-225	152	173
Width (cm)	75	75	80	78	86
Height (cm)	102	116	104	-	-
Weight (kg)	appr. 34	38	52	18	16
Boarding height(cm)	35	20"	20"	18"	20"
Front wheel	16"	20"	20"	24"	26"
Back wheel	16"	ca. 43	ca. 31	ca. 30	ca. 30
Max. load luggage rack/ basket (kg)	20	20	20	n.v.t.	n.v.t.
Max. weight user (kg)	80	120 ¹ , 150, 180	120	90 ²	120 ²
Brakes, front	V brake	V brake	V brake	V brake	V brake
Brakes, back	V brake or Back pedal brake	V brake or Back pedal brake	V brake or Back pedal brake	V brake or Back pedal brake	V brake or Back pedal brake

¹ Standard, ²Total max. load

Maintenance and adjustments to be done by owner

Below you can find the instructions for maintenance and adjustments that you can do yourself on a regular basis, which will keep your tricycle in top condition.

Cleaning

The frame of the tricycle can be cleaned with a damp cloth. For areas that are dirtier you can use a mild detergent.

The wheels can be cleaned with a moist brush with plastic hairs (not a wire brush!). The saddle, the grips and the backrest can be cleaned with mild soap and water.



Do not use a pressure washer or a steam cleaner!

The right lubricant

The chain should be cleaned and maintained at regular intervals (every three months approximately). Only use special chain grease or Teflon spray. This is the only way to make sure that the chain will run smoothly, will stay water resistant and will not rust.

1. Wipe the chain with a cloth.
2. Treat it with grease or spray.
3. Remove any excess lubricant with a rag.

Other parts should **not** be treated with a lubricant.

Inspection of the tricycle

It is recommended that the tricycle has a yearly inspection carried out by the dealer to claim warranty. Please use the form "Form service, maintenance, modifications and warranty claims" in the back of this manual. After 200 kilometres or after a period of two months the tricycle should be inspected.

In the event of technical trouble or faults, the tricycle should be taken to the dealer for repairs **immediately**.

The replacing of safety-related components (especially frame, brakes, lighting, handlebars, front fork and actuation) should be performed by the dealer.

If you still decide you want to replace components yourself, you are responsible for damage or harm due to incorrectly fitted components.

Only use **original** Van Raam spare parts, which you can buy at you dealer. If requested the dealer will make the necessary information on repair and maintenance available.

Repairs and maintenance to be done by dealer

Check the brakes, the rims, lighting, the chain tension and the spokes. Also check the tyre tread depth. This should be at least one millimetre. Worn out tyres or possible faulty parts should be replaced. Also check the parking brake. With the parking brake pulled up, the tricycle should not ride away with the cyclist.

Checking the rim

Due to the combined action of the brake and the rims, not only the brake lining but also the condition of the rim is important. For this reason the rim should be checked at regular intervals, for example when you inflate the tyres. The presence of fine cracks in the spoke punches or deformation of the rim when there is higher air pressure, indicate more serious wear and tear. In that case the rim should be replaced, because it can lead to loss of brake function or even a crack in the rim, which can lead to all kinds of dangerous consequences.

Repairs, maintenance and modifications should only be performed with original Van Raam parts.

The correct tension of the chain

The chain should not be too tight. It should hang loose. Without effort you should be able to move the chain up and down, half a centimetre approximately.

Adjusting chain tension (Husky, Mini, Midi, Maxi, Maxi Comfort, Easy Rider Junior, Easy Rider)

To keep the chain tension correct, a special tensioning wheel is fitted on to the tricycle, as an integrated chain tensioner.

1. Slightly loosen the screw. Hold the nut at the back tight with a socket wrench to stop the screw from slipping.
2. Shift the tensioning wheel in such a way that the chain hangs loose, as described above.
3. Tighten the screw again.

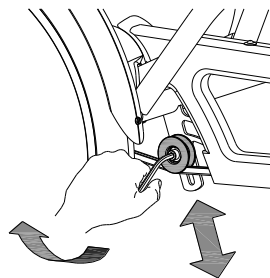
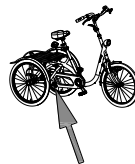

Adjusting chain tension (Viktor, Viktor)

To keep the chain tension correct, the back wheel axle is adjusted. Follow the instructions below:

1. Slightly loosen the nuts of the back wheel axle, so that the back wheel can move backwards and forwards.
2. Slide the back wheel backwards, so that the chain is hanging loose, as described earlier. Also slide the bracket (A).

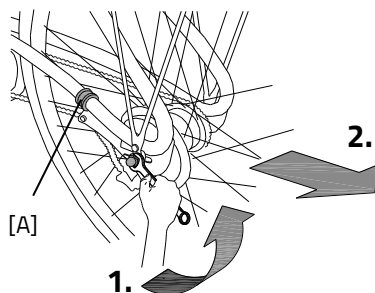

3. At the same time make sure that the wheel is straight and positioned in the centre of the frame, as illustrated. Not to the left or to the right.
4. Slightly tighten the nuts.
5. Check whether the chain tension is correct and whether the wheel is straight and in the centre of the frame.
6. Tighten the nuts again.

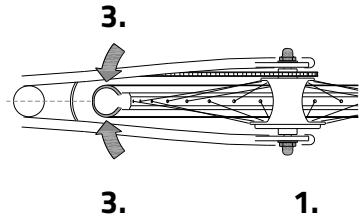

Disposal

If you want to dispose your tricycle, contact your dealer. You can also contact the local waste disposal company. They will dispose the tricycle according to the regulations of your town.

Handover/sale to a new owner

When you hand over your tricycle to a new owner it is important that you also hand over all necessary technical documentation and spare keys, so that the new owner can use the tricycle safely.

The guarantee is valid for all faults in the product, which are proven to be caused by material or manufacturing error.

We give a guarantee of five years on the frame and the front fork. For all accessories and other parts (except wear parts) we provide a two year guarantee, as legally regulated. The guarantee only applies by normal use and maintenance of the tricycle, as described in this manual.

Beware!

The guarantee as well as the product liability in general expires if the instructions stated in this manual are not followed. This is also the case if unauthorized maintenance is carried out or if technical changes or additions are made with non-original Van Raam parts without permission of Van Raam. The original CE certification will become nul-and-void if modifications are done by third parties. The absence of the certification can lead to problems in insuring your bike, and for any loss or incurred.

Frame number

The frame number is printed on the sticker. This sticker is located on the frame, see the images below. At the Viktoria and Viktor the frame number is stamped in the frame, see the images below for the positions.

Example sticker:



Position sticker Husky, Mini, Midi, Maxi and Maxi Comfort:

Husky



On the frametube

Mini



On the back of the saddle

Midi



On the back of the saddle

Maxi



On the back of the saddle

Maxi Comfort



On the back of the saddle

Position sticker Easy Rider Junior, Easy Rider and Easy Sport:

Easy Rider Junior



On the frametube

Easy Rider



On the frametube

Easy Sport



Under the chair tube

Positions of frame number, stamped in a plate on the frame (Viktoria and Viktor):

Viktoria



In a plate in front of the hinge plate

Viktor



In a plate in front of the hinge

Form service, maintenance, modifications and warranty claims

To maintain warranty on the Van Raam tricycle, follow this service schedule.

Service:	Carried out (date):	Signature dealer:
Service after the first 200 KM or two months.		
Service 1 year after delivery.		
Service 2 year after delivery.		
Service 3 year after delivery.		
Service 4 year after delivery.		
Service 5 year after delivery.		

Even after five years, we advise you to give your bike annual service. Passing by the service after five years will have no further effect on warranty claim because it expires for certain parts after five years.

Modifications to the bike

The following items are changed to the bike:

Changed:

Date:

Carried out:

Beware! Please note that if changes are made by a non-authorized Van Raam dealer or no original Van Raam parts or options are used, warranty may void.

Delivery and service form

Congratulations on your purchase of your Van Raam tricycle. This bike is produced with utmost care. To guarantee the quality as much as possible Van Raam produces the cycles according to the ISO 9001: 2008 quality standards. Van Raam has been certified by TÜV Rheinland Netherlands BV.

You will especially enjoy your Van Raam bike when the bike is adjusted to your specifications and when the instructions in the user manual are followed. Pay special attention on the service intervals who specified in the manual of the bike.

To claim warranty and service you should always fill out this form, at least at delivery and service. This signed form declares that the end user had an instruction on the operation of the tricycle, that the tricycle is adjusted to the specifications of the end user and that the user manual is received.

Fill out when the tricycle is delivered

Type Van Raam tricycle:	
Frame number:	
Key number:	
Delivered to:	
By dealer:	
Place:	
Date:	
Signature user bike:	Signature dealer:
When available, stamp dealer:	